

en

BAXI



Installation & maintenance manual

Roof top units – Axial fans

KuNB 22i-26i-32i-38i-45i-55i-65i-75i-90i-105-125-145-175-210

INDEX

INTRODUCTION	4
REGULATIONS AND CERTIFICATIONS	6
SAFETY PRECAUTIONS	7
TECHNICAL SPECIFICATIONS	8
KUNB/ 22-38	9
KUNB 45-90	10
KUNB 105-210	12
KUNB/ 22-38 RCF	14
KUNB/ 45-90 RCF	15
KUNB 105-210 RCF	16
KUNB/ 22-38 VRR	17
KUNB/ 45-90 VRR	17
OPERATION LIMITS	18
COOLING MODE	18
HEATING MODE	19
TRANSPORT	20
INSPECTION AT RECEPTION	20
LIFTING	20
STORAGE	21
DIMENSIONS AND WEIGHT	22
STANDARD MODELS	22
UNITS WITH RCF MODULE	22
UNITS WITH VRR MODULE	22
DIMENSIONS	23
22i-38i standard models	23
22i-38i models with RCF and VRR	24
45i-90i standard models	25
45i-90i models with sandwich panel	26
45i-90i models with RCF and VRR	27
45i-90i models with RCF and VRR with sandwich panel	28
Standard 105 model	29
105 RCF and VRR model	30
Standard 125-145 models	31
125-145 models with RCF and VRR	32
Standard 175-210 models	33
175-210 models with RCF and VRR	34
REFRIGERATION DIAGRAMS	35
22i- 38i models	35
45i- 90i models	36
105- 145 models	37
175- 210 models	38
INSTALLATION	39
INSTALLATION SITE	39
UNIT SETTLEMENT	39
WATER DRAIN	39
<i>Drainage – internal side</i>	39
<i>Drainage – external side</i>	39
AIR DUCTS	39
INSTALLATION	40
SERVICE AREA	42
22i to 38i models	42
22i to 38i models with RCF	42
45i to 90i models	43
45i to 90i models with RCF	43
105 model	44
105 RCF model	44
125 to 210 models	45
125 to 210 models with RCF	45

<i>Assembly types – Standard Unit</i>	46
<i>Assembly types for units with RCF module</i>	47
ELECTRICAL INSTALLATION	48
<i>ELECTRICAL CONNECTIONS</i>	48
OPERATION	50
BEFORE START-UP.....	50
START UP.....	50
MAINTENANCE	51
CONSERVATION AND CLEANING	51
LUBRICATION.....	52
REPAIRING OPERATIONS	52
SPECIAL INSTRUCTIONS FOR R32 REFRIGERANT.....	52
FAN WITH EC MOTOR.....	54
<i>Status Out with flash code</i>	55
OPTIONS	56
OUTDOOR FANS WITH PKDM / PKDT	57
<i>Led of internal state, diagnosis through flash codes</i>	57
DETECTION OF REFRIGERANT LEAKS (OPTION FOR 22/ TO 145 MODELS, STANDARD FOR 175 AND 210 MODELS).....	59
TH-TUNE OR PGD/MINI PGD (OPTION) CONTROLLERS	59
PLEASE REFER TO THE SEPARATE CONTROLLER MANUAL.....	59

INTRODUCTION

Purpose of this Manual



The present manual together with any other technical document such as refrigeration or hydraulic lines drawings and electrical diagrams among others have been issued to provide the necessary information for installation, start-up and maintenance of the unit. Therefore it is essential to read the instructions very carefully. Please contact us if your machine is equipped with an option or any special modification that are not mentioned in the present manual.

Make sure that all the necessary information for the correct installation of the system is included in the manuals that have been supplied together with this unit and/or the rest of the indoor units, accessories, etc. The manufacturer declines any responsibility in case of people/animals injuries or material damages resulting from an incorrect use of the unit and/or non-compliance with these instructions.

Should the stated data differ from one document to the other, the priority order of validity of the given documents will be: 1. Name plate of the unit stating the specifications. 2. IOM (the present document), 3. EDM, technical catalogue, 4. UM user manuals.

Storage of the Manual

This manual and the electrical diagram of the unit must be preserved and remain available to the operator for any further consultation.

Updating the Data

The continuous improvement in design and performance to which we are committed to gives us the right to modify the specifications of our products without prior notice.

Electrical Supply



Check that the electrical network features comply with the data shown in the data nameplate of the unit.

Local Safety Regulations

Observe and analyse all the possible causes of accidents that may arise in the place or places of installation of the units, check all the medium and the tools that will be used, etc. It is not possible to anticipate each one of the potential circumstances of danger in this manual. Respect the valid local security standards during installation.

Principles of Security on Installation

The unit has been designed and built so that it does not represent any risk to the health and safety of people. Appropriate solutions for the project have been adopted to eliminate the possible causes of risk in the installation.

Packaging and Replacement of Equipment



The material of the package (plastic bags, insulating materials, nails, etc.) is a potential source of danger. Consequently, it should be kept out of the reach of children and properly recycled according to the valid local safety regulations.

Do not mix this product with household waste at the end of its life. Due to the refrigerant, oil and other components contained in this product, professional installers must dismantle it. All the waste, depending on its nature shall be sent to recycling, composting or treatment plants, or to an authorized management agency in accordance with the current local legislations.

Utilization

The unit will be used only for the purpose it has been designed for. Any other use does not imply any kind of liability or responsibility from the manufacturer.

Incorrect Operation

In case of breakdowns or operation faults, turn the unit off.

INTRODUCTION

Periodic Inspections and Maintenance



Carry out periodic inspections to detect possible damaged or broken parts. If these parts are not repaired, people injuries or material damages could be caused. Disconnect the power supply of the unit before carrying out any maintenance operation.

Make sure that the maintenance areas are accessible. If these areas have to be necessarily invaded by the air supply and/or lateral return ducts, verify that the design of the ducts allows the access to the fans and that they are not a hindrance when replacing the filters. If that is not possible, make sure access is possible from the other side.

All operations shall be carried out in accordance with local safety regulations.

Repairing Operations



Trained personnel previously authorized by the manufacturer shall always and exclusively complete the reparations and only original spares shall be used. The safety devices of the unit may be damaged in case of non-compliance with these warnings.

Modifications

The manufacturer will not respond to possible warranty claims and damages of the unit in case of electrical and/or mechanical modifications. The unauthorized manipulation, reparation or modification of the unit will automatically invalidate the warranty.

Refrigerant

This product is hermetically sealed and contains a HFC fluorinated greenhouse gas.

Refrigerant type: R32

Security class according to the ISO 817 standard: A2L (lower flammability).

GWP (Global Warming Potential): 675

Please read carefully the instructions stated in the “SAFETY PRECAUTIONS” chapter as well as the detailed guidelines of the “SPECIAL INSTRUCTIONS FOR R32 REFRIGERANT”.

Do not eject refrigerant gas out to the atmosphere.

Make sure to comply with the current valid legislation.

REGULATIONS AND CERTIFICATIONS

ISO 9001 CERTIFICATION: HIPLUS AIRE ACONDICIONADO S.L., by endeavouring to always gain the maximum satisfaction from their customers, obtained the ISO 9001: Quality System for its design and production activities. That result shows our continuous determination to improve quality and the reliability of all our products. Our commercial activities, design, raw materials, production processes and after-sales service represent the means to reach our goal.

CE MARKING: Our products are CE marked according to the essential requirements of the applicable EC directives and their last modifications and comply with the national legislation of each country.



Please go to the website for the Declaration of Conformity:

<https://declaration-of-conformity.bdrthermeagroup.com>



EUROVENT CERTIFICATION: HITECSA participates in the EUROVENT Certification program. Please check which models are certified on the web.



- 2014/35/EU Low Voltage Directive.
- 2014/30/EU Electromagnetic Compatibility Directive.
- RoHS 2011865/EU Directive.
- 2009/125/EC Ecodesign Directive.
- 2006/42/EC Machinery Directive.

SAFETY PRECAUTIONS



Before starting any installation, service or maintenance operation, turn the main power switch off in order to avoid electrical discharges that may cause personal injuries.

- Should it be necessary to open the electrical box to access the internal part of the equipment, previously plug the main power cable out. The equipment **MUST ALWAYS BE FREE OF VOLTAGE** when opening the electrical box.
- It is absolutely forbidden to carry out work on electrical live parts. The protection class of the opened unit is IP00!
- Control that power supply is isolated correctly by using a minimum two-pole voltage detector.
- Always provide the unit with a correct grounding according to its capacity.
- The power cables must be straight without any knot and shall be installed totally stretched out. They shall be free of any defect.
- Never pull on the power cables even when the unit is in the Off position or disconnected as that might cause fire or other severe damages.
- There shall not be any external conductive part within minimum 2.5 m from the unit.



WARNING

Even though the flammability level of the refrigerant is lower, there does exist a potential risk of fire if the use and maintenance instructions are not followed scrupulously.

Please pay attention in particular to the following:

- Do not store or install the unit in places where there are sources of ignition, operating gas devices or electric heating equipment.
- Make sure to indicate clearly on site that it is forbidden to smoke.
- Do not perforate the unit and do not expose it to fire.
- Do not use any heating device to speed the defrosting process up or for cleaning.
- In case of transport of the unit please check the requirements regarding International transport of dangerous goods according to the UN 3358 standard and implement the necessary measures (marking, labels,...) for transport of equipment charged with a A2L class refrigerant.



DANGER

- Do not touch or adjust the safety devices inside the unit. For repairs use original spare parts only and install them properly in the same position where the old parts were fitted.
- The installation and maintenance of air conditioning equipment may be dangerous due to the pressure of the system, the high temperature of some of its parts and the electrical components.
- Do not install the unit in an explosive atmosphere.
- Do not install the unit in indoor areas where there are oil vapors, possibly inflammable, erosive and/or corrosive substances.
- If the motor of the fan runs independently after the unit has been switched off due to strong air currents for example, dangerous voltage of more than 50 V may be present in some of the internal connection parts of the motor. In that case the fan is working as a generator.
- When the unit is equipped with EC motors or motors with variable speed control, the ground wire (depending on the switching frequency, the current source voltage and the motor capacity) is conducting high discharge currents. Therefore check that the earth grounding is complying with the EN standards even for testing and trial operations (EN 50 178, Art. 5.2.11). Without grounding dangerous voltages may be present in the motor housing.
- The use of capacitors may represent a danger of death even after switching the device off in case of direct contact with conductive parts or with parts that carry voltage if they are damaged. Removing or opening the housing of the controller and the terminal box for example is only permitted after the power supply cable has been disconnected for 3 minutes.

SAFETY PRECAUTIONS



ATTENTION!

- Only qualified and trained service staff (technical service) are authorized to carry out installation, commissioning and maintenance. Unqualified personnel will carry out basic tasks only such as cleaning and replacement of filters, or filter cleaning (excluding the refrigerant filters), etc...
- Prevent access to children so that they cannot play with the equipment.
- Before installation, make sure that all operations will be completed in well ventilated areas.
- For all visits, follow carefully all recommended precautions: the instructions recommended in the installation, operation and maintenance manual, as well as the precautions stated on the stickers placed on the unit. Do not forget to strictly follow any other legal safety instructions.
- DO NOT introduce objects into the air inlets or outlets as they might be drawn into the fan, people, etc.
- The fan / motor may start and stop automatically due to functional reasons.
- After a power failure or a main disconnection an automatic restart of the fan takes place when power supply returns!
- Never approach the fan until it has stopped completely! Beware as it may be rotating even without electric power but airflow for example.
- When the motor is provided with an external rotor, the rotor rotates during operation.
- Use safety glasses, work gloves and any other safety accessory that may be necessary for the operation.
- For brazing operations use a quenching cloth and make sure you have a fire extinguisher close to you.
- This product contains fluorinated greenhouse gases. In case of leakage air may be displaced which may cause lack of oxygen.
- Do not install the unit in places close to continuously burning fire such as gas heaters, etc...
- Please follow all the safety recommendations carefully.



WARNING!

The responsibility for all personal and material damages caused by an unexpected or inappropriate use will be born by the person or the operating company of the unit and not by the manufacturer.

TECHNICAL SPECIFICATIONS

KuNB*i* 22-38

KuNB <i>i</i> models		22 <i>i</i>	26 <i>i</i>	32 <i>i</i>	38 <i>i</i>
KUBIC NEXT range		CAPACITIES			
(1) COOLING CAPACITY (Outdoor: 35°C - Indoor: 27 d.b./19°C h.b.)					
Nominal COOLING capacity	kW	21.3	26.4	32.6	38.1
Total Absorbed power	kW	7.6	9.4	11.6	13.6
EER	-	2.80	2.80	2.80	2.80
Air flow	m ³ /h	4500	5000	6250	7500
Available pressure	kPa	120	120	150	150
SEER	-	5.20	4.81	4.91	5.17
η _s cooling	%	200.2	185.1	188.4	198.7
(2) HEATING CAPACITY (Outdoor: 7 d.b. /6°C h.b. - Indoor: 20/-°C)					
HEATING capacity	kW	22.1	26.2	32.9	38.3
Total Absorbed power	kW	6.7	7.9	10.0	11.6
COP Coefficient	-	3.30	3.30	3.30	3.30
SCOP coefficient	-	3.32	3.33	3.35	3.33
η _s heating	%	130.0	130.1	131.0	130.0
REFRIGERANT CIRCUIT					
GENERAL SPECIFICATIONS					
Number of circuits	-	1			
Number of compressors	-	1			
Number of power stages	-	Variable			
REFRIGERANT					
Refrigerant type	-	R32			
GWP ⁽³⁾	-	675			
Refrigerant charge	kg	7,5	7,8	12,5	10
OUTDOOR HEAT EXCHANGER					
Type	-	Aluminium fins and copper tubes coil			
Condensate drain connection	∅	3/4" Gas			
OUTDOOR FAN					
Type	-	Axial EC			
Total number	-	1			
Air flow (nominal)	m ³ / h	18000			
Static pressure (nominal conditions)	Pa	0			
INDOOR HEAT EXCHANGER					
Type	-	Aluminium fins and interwoven copper tubes coil			
Quantity	-	1			
INDOOR FAN					
Type	-	Radial EC			
Total number	-	1			
Air flow (nominal)	m ³ / h	4500	5000	6250	7500
Available static pressure (nominal conditions)	Pa	120	120	150	150
Static pressure (Maximum)	Pa	850	847	667	514
Maximum static pressure of the upgraded fan	Pa	-	-	1200	950
ELECTRICAL DATA					
General power supply	V / ~/Hz	400V / 3ph + N / 50Hz			
Maximum operation current ⁽⁴⁾	A	25	31	30.4	41.4
SOUND LEVEL					
Sound power	dB(A)	79.7	80.9	84.1	85.6
Sound pressure (5 m)	dB(A)	58.2	59.4	62.6	64.1
DIMENSIONS AND WEIGHT					
Length	mm	2600			
Width	mm	1720			
Height	mm	1665			
Weight	kg	890	893	925	928

(1) Calculated according to the UNE-EN-14511 standard, for indoor temperature conditions of 27°C D.B. / 19°C H.B. and 35°C outdoor temperature.

(2) Calculated according to the UNE-EN-14511 standard, for indoor temperature conditions of 20°C and 7°C D.B. / 6°C H.B. outdoor temperature.

(3) Global warming potential of one kg of fluorinated gas in relation to one kg of carbon dioxide over a period of 100 years. According to the "Fifth Assessment Report (AR5)" of the IPCC (Intergovernmental Panel on Climate Change).

(4) MOC: Maximum Operation Current: sum of the maximum (or nominal) operation currents of all the motors when they are running at the same time. Please refer to this value when selecting the power cables of the installation.

TECHNICAL SPECIFICATIONS

KuNB 45-90

KuNB <i>i</i> models		45 <i>i</i>	55 <i>i</i>	65 <i>i</i>	75 <i>i</i>	90 <i>i</i>
KUBIC NEXT range	CAPACITIES					
(1) COOLING CAPACITY (Outdoor: 35°C - Indoor: 27 d.b./19°C h.b.)						
Nominal COOLING capacity	kW	41.9	52.0	63.4	75.4	85.0
Total Absorbed power	kW	14.5	18.6	21.2	26.9	30.4
EER	kW/ kW	2.88	2.80	2.99	2.80	2.80
Air flow	m ³ /h	8400	10400	12000	14400	16500
Available pressure	Pa	150	200	200	200	250
SEER	kW/ kW	4.37	4.11	4.19	4.16	4.18
η _s cooling	%	171.7	161.6	164.4	163.5	164.2
(2) HEATING CAPACITY (Outdoor: 7 d.b. /6°C h.b. - Indoor: 20/-°C)						
HEATING capacity	kW	41.5	52.0	67.0	76.4	87.7
Total Absorbed power	kW	13.1	15.9	20.5	23.5	27.4
COP Coefficient	kW/ kW	3.20	3.28	3.27	3.25	3.20
Air flow	m ³ /h	8400	10400	12000	14400	16500
SCOP coefficient	kW/ kW	3.36	3.22	3.31	3.28	3.24
η _s heating	%	131.3	125.9	129.3	128.3	126.7
ELECTRICAL DATA						
General power supply	V / ~/Hz	400V / 3ph / 50Hz Without neutral				
Maximum operation current ⁽⁴⁾	A	49	53.3	61.3	62.9	82.6
Start-up current	A	130	155	175.2	182.2	224.4
REFRIGERANT CIRCUIT						
GENERAL SPECIFICATIONS						
Number of circuits	-	2				
Number of compressors	-	2				
Number of power stages	-	Multiple				
REFRIGERANT						
Refrigerant type		R32				
GWP ⁽³⁾		675				
Refrigerant charge Circuit 1	kg	7,5	7	10		9
Refrigerant charge Circuit 2	kg	6,5	6	9,5	8,5	8
CIRCUIT 1						
Compressor type	-	Scroll				
Number of compressors	-	1				
Number of power stages	-	Inverter				
Oil type	-	FW68S				
Oil volume	L	1.40		2.30		
CIRCUIT 2						
Compressor type	-	Scroll				
Number of compressors	-	1				
Number of power stages	-	1				
Oil type	-	POE185SL	BVC32			
Oil volume	L	3.30	2.70			
Crankcase heater	W	90				

(1) Calculated according to the UNE-EN-14511 standard, for indoor temperature conditions of 27°C D.B. / 19°C H.B. and 35°C outdoor temperature.

(2) Calculated according to the UNE-EN-14511 standard, for indoor temperature conditions of 20°C and 7°C D.B. / 6°C H.B. outdoor temperature.

(3) Global warming potential of one kg of fluorinated gas in relation to one kg of carbon dioxide over a period of 100 years. According to the "Fifth Assessment Report (AR5)" of the IPCC (Intergovernmental Panel on Climate Change).

(4) MOC: Maximum Operation Current: sum of the maximum (or nominal) operation currents of all the motors when they are running at the same time. Please refer to this value when selecting the power cables of the installation.

TECHNICAL SPECIFICATIONS

KuNBi 45-90

KuNBi models		45i	55i	65i	75i	90i
OUTDOOR HEAT EXCHANGER						
Type	-	Aluminium fins and copper tubes coil.				
Condensate drain connection	∅	3/4" Gas				
OUTDOOR FAN						
Type	-	Axial				
Total number	-	2				
Air flow	m ³ /h	40000				44000
Static pressure	Pa	0				
INDOOR HEAT EXCHANGER (AIR)						
Type	-	Aluminium fins and interwoven copper tubes coil				
Quantity	-	1				
INDOOR FAN						
Type	-	Radial EC				
Total number	-	2				
Air flow	m ³ /h	8400	10400	12000	14400	16500
Available static pressure	Pa	150	200	200	200	250
Static pressure (Maximum Available)	Pa	780	611	641	490	237
Maximum available pressure Upgraded Fan	Pa	1300	1100	1350	1100	1250
SOUND LEVEL						
Sound power	dB(A)	82.5	83.5	88.5	88.5	89.6
Sound pressure (5 m)	dB(A)	61.0	62.0	67.0	67.0	68.2
DIMENSIONS AND WEIGHT						
DIMENSIONS						
Length	mm	2900				
Width	mm	2215				
Height	mm	1830				
WEIGHT						
Net Heat pump	kg	1222	1230	1307	1323	1377

TECHNICAL SPECIFICATIONS

KuNB 105-210

KuBN models		105	125	145	175	210
KUBIC NEXT range	CAPACITIES					
(1) COOLING CAPACITY (Outdoor: 35°C - Indoor: 27 d.b./19°C h.b)						
Nominal COOLING capacity	kW	103.7	125.4	145.6	174,4	210,4
Total Absorbed power	kW	34.0	38.1	45.1	57,0	74,9
EER	kW/ kW	3.04	3.30	3.23	3,06	2,81
Air flow	m³/h	18000	22000	24000	28500	35000
Available pressure	Pa	250	300	300	350	350
SEER	kW/ kW	4.20	4.14	4.09	4,02	3,95
η _s cooling	%	165.1	162.4	160.4	157,9	155,0
(2) HEATING CAPACITY (Outdoor: 7 d.b. /6°C h.b. - Indoor: 20/-°C)						
HEATING capacity	kW	103.1	129.8	153.9	192.3	242.4
Total Absorbed power	kW	30.3	36.6	45.5	58.1	81.7
COP Coefficient	kW/ kW	3.40	3.55	3.38	3.31	2.97
Air flow	m³/h	18000	22000	24000	28500	35000
SCOP Coefficient	kW/ kW	3.34	3.32	3.21	3.26	3.20
η _s heating	%	130.5	129.7	125.3	127.4	125.0
REFRIGERANT CIRCUIT						
GENERAL SPECIFICATIONS						
Number of circuits	-			2		
Number of compressors	-	3				4
Number of power stages	-			4		
REFRIGERANT						
Refrigerant type	-			R32		
GWP ⁽³⁾	-			675		
Refrigerant charge Circuit 1	kg	12		18	20,5	
Refrigerant charge Circuit 2	kg	12		22	22	
CIRCUIT 1						
Compressor type	-			Scroll		
Number of compressors	-			2		
Number of power stages	-	2	3			
Oil type	-			BVC32		
Oil volume	L	2.7+2.7		2.7+5.3		
Crankcase heater	W	90+90		90+140		
CIRCUIT 2						
Compressor type	-			Scroll		
Number of compressors	-	1		2		
Number of power stages	-	1		3		
Oil type	-			BVC32		
Oil volume	L	2.7	5.3	5.3	2.7+5.3	2.7+5.3
Crankcase heater	W	90		140	90+90	90+140

(1) Calculated according to the UNE-EN-14511 standard, for indoor temperature conditions of 27°C D.B. / 19°C H.B. and 35°C outdoor temperature.

(2) Calculated according to the UNE-EN-14511 standard, for indoor temperature conditions of 20°C and 7°C D.B. / 6°C H.B. outdoor temperature.

(3) Global warming potential of one kg of fluorinated gas in relation to one kg of carbon dioxide over a period of 100 years. According to the "Fifth Assessment Report (AR5)" of the IPCC (Intergovernmental Panel on Climate Change).

TECHNICAL SPECIFICATIONS

KuNB 105-210

KuNB models		105	125	145	175	210
OUTDOOR HEAT EXCHANGER						
Type	-	Aluminium fins and copper tubes coil.				
Condensate drain connection	Ø	3/4" Gas				
OUTDOOR FAN						
Type	-	Axial EC				
Total number	-	2	4			
Air flow	m³/h	44000	48000	56000	76000	76000
Available static pressure	Pa	0				
INDOOR HEAT EXCHANGER (AIR)						
INDOOR FAN						
Type	-	Radial EC				
Total number	-	3				
Air flow	m³/h	18000	22000	24000	28500	35000
Available static pressure	Pa	250	300		350	
Static pressure (Maximum Available)	Pa	750	700	600	800	400
Max. available static pressure Upgraded Fan	Pa	1150	1000	900	1000	800
ELECTRICAL DATA						
General Power Supply	V / ~/Hz	400V / 3ph / 50Hz without neutral				
Maximum Operation current ⁽⁴⁾	A	94.1	110.4	123.7	146.2	191.8
Start current	A	235.9	280.1	280.7	288.0	348.8
SOUND LEVEL						
Sound power	dB(A)	88.3	89.0	90.8	88.5	93.9
Sound pressure (5 m)	dB(A)	66.9	67.5	69.4	67.0	72.4
DIMENSIONS AND WEIGHT						
Length	mm	3986			4330	
Width	mm	2242			2240	
Height	mm	2430			2300	
Weight	kg	1810	1840	1861	3014	3032

⁽⁴⁾ MOC: Maximum Operation Current: sum of the maximum (or nominal) operation currents of all the motors when they are running at the same time. Please refer to this value when selecting the power cables of the installation.

TECHNICAL SPECIFICATIONS

KuNB*i* 22-38 RCF

KUBIC NEXT RCF	CAPACITIES				
	22 <i>i</i>	26 <i>i</i>	32 <i>i</i>	38 <i>i</i>	
(1) COOLING CAPACITY (60% Outdoor air renewal: 35°C d.b. /24°h.b.- Indoor: 27 d.b./19°C h.b.)					
Nominal cooling capacity	kW	26.7	33.1	40.6	48.3
Total absorbed power	kW	9.9	12.8	14.2	17.0
EER	kW/ kW	2.7	2.6	2.9	2.8
(2) HEATING CAPACITY (60% Outdoor air renewal: 7°C d.b. /6°C h.b. - Indoor: 20°C d.b./14°C h.b.)					
Heating capacity	kW	25.8	33.1	41.8	47.1
Total absorbed power	kW	7.1	10.6	11.7	13.8
COP coefficient	kW/ kW	3.6	3.1	3.6	3.4
REFRIGERANT					
Refrigerant type	-	R32			
GWP ⁽³⁾	-	675			
Refrigerant charge	kg	1		1,4	
CIRCUIT RCF					
Compressor type	-	On-Off			
Number of compressors	-	1			
Number of power stages	-	1			
Oil type	-	VG74			
Oil volume	L	0,6		0,9	
Crankcase heater	W	No			
RETURN FAN					
Type	-	Radial EC			
Total number	-	1			
Air flow (n.f.)	m³/ h	4500	5000	6250	7500
Static pressure (n.f.)	Pa	100			
Maximum static pressure	Pa	900	700	220	200
ELECTRICAL DATA					
General power supply	V / ~/Hz	400V / 3ph + N / 50Hz			
Maximum Operation Current ⁽⁴⁾	A	37.8	43.8	47.2	58.4
Start current (AC)	A	70.8	76.8	95.2	106.4
SOUND LEVEL					
Sound power	dB(A)	83.7	84.0	87.6	88.1
Sound pressure (at 5 m)	dB(A)	62.2	62.5	66.2	66.6
DIMENSIONS					
Length	mm	3760			
Width	mm	1720			
Height	mm	1665			
WEIGHT					
Weight	kg	1210	1212	1238	1247

(1) Calculated with 60% new air. For indoor temperature conditions (Extraction): 27°C d.b. / 19°C h.b. and Outdoor temperature (Renewal): 35°C d.b. / 24°C h.b.

(2) Calculated with 60% new air. For indoor temperature conditions: 20°C d.b. /14°C h.b. and outdoor temperature: 7°C d.b. / 6°C h.b.

(3) Global warming potential of one kg of fluorinated gas in relation to one kg of carbon dioxide over a period of 100 years.

According to the "Fifth Assessment Report (AR5)" of the IPCC (Intergovernmental Panel on Climate Change).

(4) MOC: Maximum Operation Current: sum of the maximum (or nominal) operation currents of all the motors when they are running at the same time. Please refer to this value when selecting the power cables of the installation.

TECHNICAL SPECIFICATIONS

KuNB*i* 45-90 RCF

KUBIC NEXT RCF	45 <i>i</i>		55 <i>i</i>		65 <i>i</i>		75 <i>i</i>		90 <i>i</i>	
	CAPACITIES									
(1) COOLING CAPACITY (60% Outdoor air renewal: 35°C d.b. /24°h.b.- Indoor: 27 d.b./19°c h.b.)										
Nominal cooling capacity	kW	63.8	75.4	95.6	106.7	117.5				
Total absorbed power	kW	23.6	27.9	33.2	37.8	40.6				
EER	kW/ kW	2.71	2.70	2.88	2.82	2.90				
(2) HEATING CAPACITY (60% Outdoor air renewal: 7°C d.b. /6°c h.b. - Indoor: 20°c d.b./14°c h.b.)										
Heating capacity	kW	66.7	77.6	97.1	107.6	124.6				
Total absorbed power	kW	19.2	23.5	29.7	32.7	40.3				
COP coefficient	kW/ kW	3.47	3.31	3.26	3.29	3.09				
REFRIGERANT										
Refrigerant type	-					R32				
GWP ⁽³⁾	-					675				
Refrigerant charge	kg	3		4		4,2				
CIRCUIT RCF										
Compressor type	-					Scroll				
Number of compressors	-					1				
Number of power stages	-					1				
Oil type	-					FW68S				
Oil volume	L	1.40			2.30					
Crankcase heater	W					48				
RETURN FAN										
Type	-					Radial EC				
Total number	-					2				
Air flow (N.F.)	m³/ h	8400	10400	12000	14400	16500				
ELECTRICAL DATA										
General power supply	V / ~/Hz	400V / 3ph / 50Hz without neutral								
Maximum Operation Current ⁽⁴⁾	A	73.6	77.9	91.3	92.9	112.6				
SOUND LEVEL										
Sound power	dB(A)	84.2	85.3	90.1	90.0	91.2				
Sound pressure (at 5 m)	dB(A)	62.7	63.8	68.6	68.6	69.8				
DIMENSIONS										
Length	mm					3975				
Width	mm					2215				
Height	mm					1825				
WEIGHT										
Weight	kg	1682	1690	1767	1783	1837				

(1) Calculated with 60% new air. For indoor temperature conditions (Extraction): 27°C d.b. / 19°C h.b. and Outdoor temperature (Renewal): 35°C d.b. / 24°C h.b.

(2) Calculated with 60% new air. For indoor temperature conditions: 20°C d.b. /14°C h.b. and outdoor temperature: 7°C d.b. / 6°C h.b.

(3) Global warming potential of one kg of fluorinated gas in relation to one kg of carbon dioxide over a period of 100 years.

According to the "Fifth Assessment Report (AR5)" of the IPCC (Intergovernmental Panel on Climate Change).

(4) MOC: Maximum Operation Current: sum of the maximum (or nominal) operation currents of all the motors when they are running at the same time. Please refer to this value when selecting the power cables of the installation.

TECHNICAL SPECIFICATIONS

KuNB 105-210 RCF

KUBIC NEXT RCF		105	125	145	175	210
	CAPACITIES					
	(1) COOLING CAPACITY (60% Outdoor air renewal: 35°C d.b. /24°h.b.- Indoor: 27 d.b./19°C h.b.)					
Nominal cooling capacity	kW	143.2	168.6	185.0	249.5	270.3
Total absorbed power	kW	44.0	55.0	67.7	87.7	101.3
EER	kW/ kW	3.25	3.07	2.73	2.84	2.67
	(2) HEATING CAPACITY (60% Outdoor air renewal: 7°C d.b. /6°C h.b. - Indoor: 20C d.b./14°C h.b.)					
Heating capacity	kW	151.1	169.8	188.6	249.5	276.6
Total absorbed power	kW	39.5	48.0	56.5	74.9	84.4
COP coefficient	kW/ kW	3.83	3.54	3.34	3.33	3.28
	REFRIGERANT					
Refrigerant type	-	R32				
GWP ⁽³⁾	-	675				
Refrigerant charge	kg	3,5	4,8	4,5	7	7,5
	CIRCUIT RCF					
Compressor type	-	Scroll				
Number of compressors	-	1				
Number of power stages	-	1				
Oil type	-	FW68S				
Oil volume	L	3.3				
Crankcase heater	W	48				
	RETURN FAN					
Type	-	Radial EC				
Total number	-	3				
Air flow (N.F.)	m³/ h	18000	22000	24000	28500	35000
	ELECTRICAL DATA					
General power supply	V / ~/Hz	400V / 3ph / 50Hz without neutral				
Maximum Operation Current ⁽⁴⁾	A	126.8	145.4	160.2	208.4	230.6
	SOUND LEVEL					
Sound power	dB(A)	90.2	90.5	92.7	90.3	96.0
Sound pressure (5 m)	dB(A)	68.7	69.0	71.2	68.8	74.6
	DIMENSIONS					
Length	mm	5930			6360	
Width	mm	2242			2240	
Height	mm	2430			2300	
	WEIGHT					
Weight	kg	2783	2813	2834	4029	4047

(1) Calculated with 60% new air. For indoor temperature conditions (*Extraction*): 27°C d.b. / 19°C h.b. and Outdoor temperature (*Renewal*): 35°C d.b. / 24°C h.b..

(2) Calculated with 60% new air. For indoor temperature conditions: 20°C d.b. /14°C h.b. and outdoor temperature: 7°C d.b. / 6°C h.b.

(3) Global warming potential of one kg of fluorinated gas in relation to one kg of carbon dioxide over a period of 100 years.

According to the "Fifth Assessment Report (AR5)" of the IPCC (Intergovernmental Panel on Climate Change).

(4) MOC: Maximum Operation Current: sum of the maximum (or nominal) operation currents of all the motors when they are running at the same time. Please refer to this value when selecting the power cables of the installation.

TECHNICAL SPECIFICATIONS

KuNB*i* 22-38 VRR

SERIE KUBIC NEXT VRR	22 <i>i</i>				26 <i>i</i>	32 <i>i</i>	38 <i>i</i>
	CAPACITIES						
(1) COOLING CAPACITY (60% Outdoor air renewal: 35°C d.b. /24°h.b.- Indoor: 27 d.b./19°C h.b.)							
Nominal cooling capacity	kW	21,1	27,9	33,4	40,3		
Total absorbed power	kW	8,6	11,6	12,2	15,4		
EER	-	2,44	2,41	2,74	2,63		
(2) HEATING CAPACITY (60% Outdoor air renewal: 7°C d.b. /6°C h.b. - Indoor: 20°C d.b./14°C h.b.)							
Heating capacity	kW	20,4	27,4	32,7	38,1		
Total absorbed power	kW	5,3	8,7	8,3	9,9		
COP coefficient	-	3,82	3,14	3,92	3,86		
RETURN FAN							
Type	-	Radial EC					
Total number	-	1					
Air flow	m ³ /h	18000					
ELECTRICAL DATA							
General power supply	V / ~/Hz	400V / 3ph / 50Hz with neutral					
Maximum Operation Current ⁽⁴⁾	A	28,8	34,8	34,2	45,4		
DIMENSIONS							
Length	mm	3760					
Width	mm	1720					
Height	mm	1665					
WEIGHT							
Weight	kg	1092	1094	1120	1129		

KuNB*i* 45-90 VRR

KUBIC NEXT VRR	45 <i>i</i>		55 <i>i</i>	65 <i>i</i>	75 <i>i</i>	90 <i>i</i>
	CAPACITIES					
(1) COOLING CAPACITY (60% Outdoor air renewal: 35°C d.b. /24°h.b.- Indoor: 27 d.b./19°C h.b.)						
Nominal cooling capacity	kW	45.2	55.9	71.7	81.4	91.2
Total absorbed power	kW	15.7	20.7	25.1	29.9	32.9
EER	kW/ kW	2.89	2.70	2.85	2.72	2.78
(2) HEATING CAPACITY (60% Outdoor air renewal: 7°C d.b. /6°C h.b. - Indoor: 20°C d.b./14°C h.b.)						
Heating capacity	kW	43.1	53.8	69.1	78.7	93.0
Total absorbed power	kW	10.3	13.7	17.1	19.8	25.6
COP coefficient	kW/ kW	4.17	3.92	4.04	3.97	3.64
RETURN FAN						
Type	-	Radial EC				
Total number	-	2				
Air flow	m ³ /h	8400	10400	12000	14400	16500
ELECTRICAL DATA						
General power supply	V / ~/Hz	400V / 3ph / 50Hz without neutral				
Maximum Operation Current ⁽⁴⁾	A	56.6	60.9	69.3	70.9	90.6
DIMENSIONS						
Length	mm	3975				
Width	mm	2215				
Height	mm	1825				
WEIGHT						
Weight	kg	1522	1530	1607	1623	1675

OPERATION LIMITS

COOLING MODE

		22i	26i	32i	38i	45i	55i	65i	75i	90i	105	125	145	175	210
Minimum Outdoor Temperature	°C	-15	-15	-15	-15	-15	-15	-15	-15	-15	-15	-15	-15	-15	-15
Maximum Outdoor Temperature (Unit at min. capacity)	°C	55	55	55	55	55	55	55	55	55	55	55	55	55	55
Maximum Outdoor Temperature (Unit at max. capacity)	°C	48	48	48	48	48	48	48	48	48	48	48	47	48	47
Minimum Indoor Temperature	°C	18	18	18	18	18	18	18	18	18	18	18	18	18	18
Maximum Indoor Temperature	°C	32	32	32	32	32	32	32	32	32	32	32	32	32	32

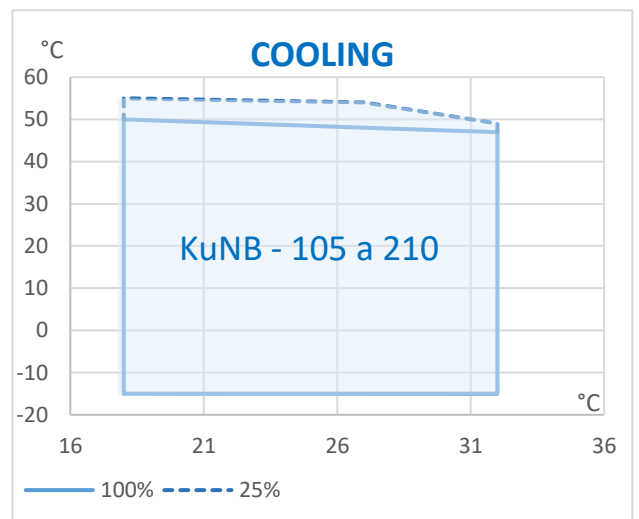
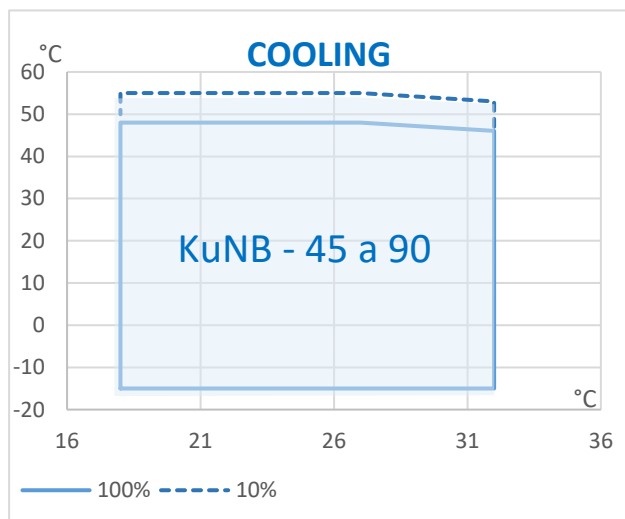
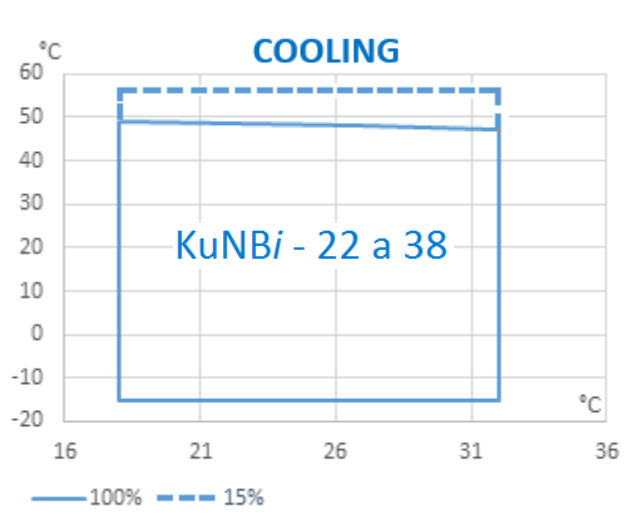

OPERATION LIMITS

HEATING MODE

		22i	26i	32i	38i	45i	55i	65i	75i	90i	105	125	145	175	210
Minimum Outdoor Temperature	°C	-12	-12	-12	-12	-12	-12	-12	-12	-12	-12	-12	-12	-12	-12
Maximum Outdoor Temperature	°C	25	25	25	25	25	25	25	25	25	25	25	25	25	25
Minimum Indoor Temperature	°C	15	15	15	15	15	15	15	15	15	15	15	15	15	15
Maximum Indoor Temperature	°C	27	27	27	27	27	27	27	27	27	27	27	27	27	27

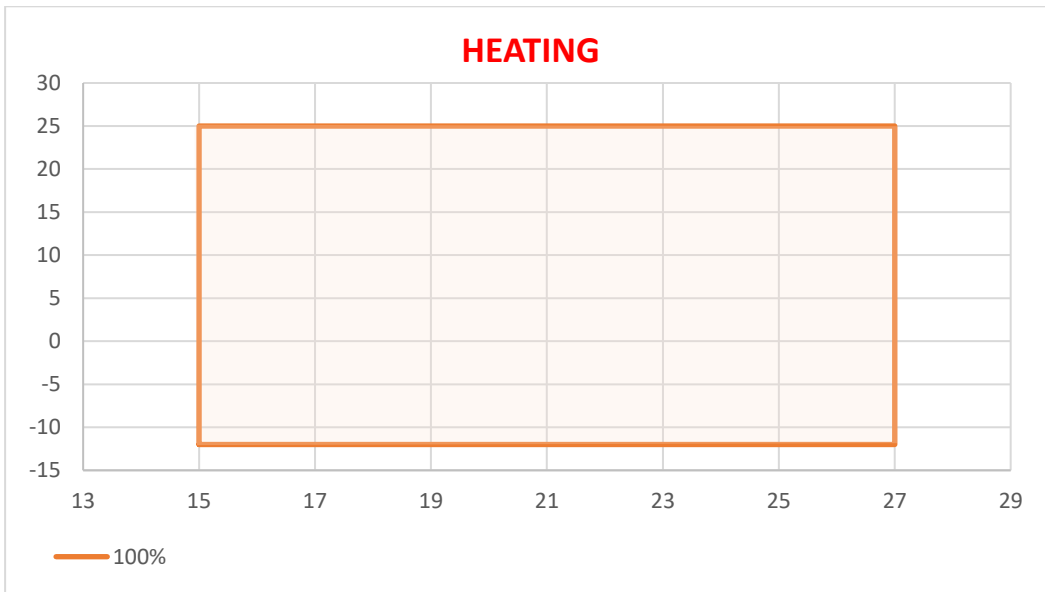

TRANSPORT

INSPECTION AT RECEPTION

- It is advisable to examine the equipment carefully upon reception.
- Check that the equipment has not been damaged during transport and that it is complete with all the parts specified in the order and/or the options stated in the order. If this is not the case, please contact the transport company immediately (within 48h).
- Verify the correct voltage of the nameplate and make sure it is in accordance with local power supply.
- In case of any flaw or anomaly detected, please contact HITECSA.

LIFTING

- Before moving the unit, make sure that all panels are fixed properly.
- Raise and put the equipment down carefully.
- Do not tilt the unit more than 15 degrees during transportation.
- Always transport the unit in its original packaging to the place of installation.
- All units come with a particular rigging diagram of that model similar to the one shown below. Be sure to hoist the machine through the points indicated in the diagram.
- Make sure that the unit is balanced, stable and without any deformations during the lifting operations.

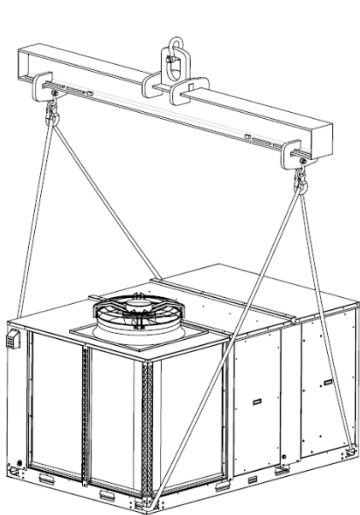

22i - 38i models

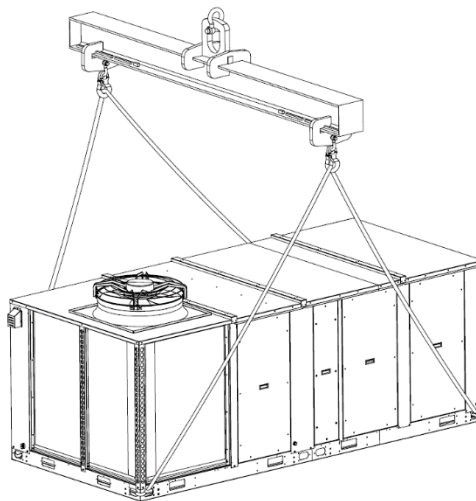

22i - 38i + RCF/VRR models

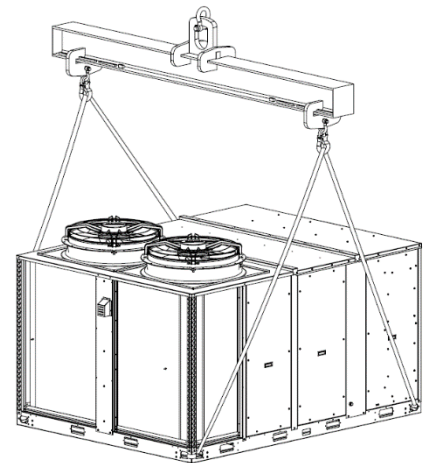

45i - 90i models

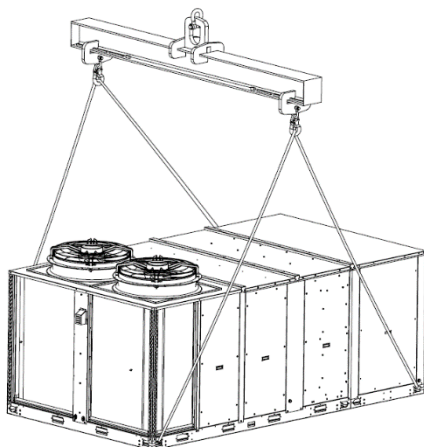

45i - 90i + RCF/VRR models

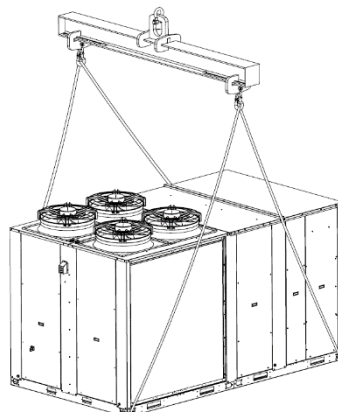

105 - 210 models

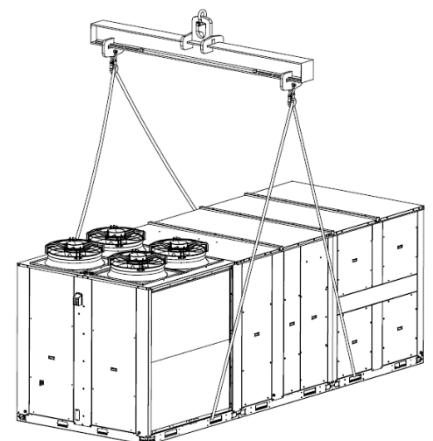

105 - 210 + RCF/VRR models

STORAGE

If the equipment is going to be stored before the installation, please follow the following instructions in order to avoid damages, corrosion or deterioration:

- Move the equipment carefully.
- Do not place the unit in places exposed to ambient temperatures above 50°C and preferably keep the unit away from direct sunlight.
- Avoid placing the unit with plastic wrapping protection under the sun as the pressure of the circuits could reach values that could lead to the activation of the safety valves.

Moreover, with decreasing temperatures water condensation may occur inside the machine and the plastic wrap.

- Avoid placing other objects on top of the unit (unless this is done within the limits of the overlap planes indicated on the packaging, etc).
- Avoid prolonged storage before installation, water penetration, dust and objects in general due to invasion or biological, meteorological and/or human impacts.
- Minimum storage temperature: -10°C (No water must be stocked inside the equipment).
- Maximum relative humidity: 90%.

DIMENSIONS AND WEIGHT STANDARD MODELS

MODEL	WEIGHT	REACTIONS (kg)							
	kg	R1	R2	R3	R4	R5	R6	R7	R8
22i	890	151	224	93	91	202	128	-	-
26i	893	153	225	93	91	203	128	-	-
32i	925	160	234	95	93	210	133	-	-
38i	928	162	236	95	93	210	133	-	-
45i	1222	176	258	157	184	284	163	-	-
55i	1230	177	260	158	185	286	164	-	-
65i	1307	188	276	168	196	304	174	-	-
75i	1323	191	280	170	199	307	176	-	-
90i	1377	198	291	177	207	320	183	-	-
105	1810	250	464	210	245	435	207	-	-
125	1840	257	475	212	250	438	208	-	-
145	1861	261	479	213	254	443	210	-	-
175	3014	440	794	309	429	736	305	-	-
210	3032	447	796	309	436	738	305	-	-

UNITS WITH RCF MODULE

MODEL	WEIGHT	REACTIONS (kg)							
	kg	R1	R2	R3	R4	R5	R6	R7	R8
22i	1210	160	292	125	174	315	144	-	-
26i	1212	160	292	127	174	315	144	-	-
32i	1238	162	292	139	174	327	144	-	-
38i	1247	168	293	141	174	327	144	-	-
45i	1682	218	265	163	114	262	362	180	119
55i	1690	166	296	232	146	167	301	234	147
65i	1767	174	309	243	153	175	315	245	154
75i	1783	176	312	244	154	177	318	247	155
90i	1837	178	319	257	161	179	323	259	162
105	2783	253	528	412	216	251	507	402	214
125	2813	261	551	404	213	258	522	392	212
145	2834	262	552	408	215	259	526	397	214
175	4029	396	700	657	289	391	674	635	287
210	4047	399	707	656	289	394	681	634	287

UNITS WITH VRR MODULE

MODEL	WEIGHT	REACTIONS (kg)							
	kg	R1	R2	R3	R4	R5	R6	R7	R8
22i	1092	160	266	83	174	287	122	-	-
26i	1094	160	266	85	174	287	122	-	-
32i	1120	162	266	96	174	300	122	-	-
38i	1129	168	266	99	174	300	122	-	-
45i	1522	197	240	148	103	237	327	163	108
55i	1530	151	268	210	132	152	272	212	133
65i	1607	158	281	221	139	159	286	223	140
75i	1623	160	284	222	140	161	290	225	141
90i	1675	163	291	234	147	163	295	236	148
105	2596	245	518	360	192	242	496	352	191
125	2626	252	540	353	191	248	509	344	189
145	2647	255	545	353	191	251	516	345	190
175	3804	392	708	570	259	386	678	553	258
210	3822	395	715	569	259	389	684	553	258

DIMENSIONS

22i-38i standard models

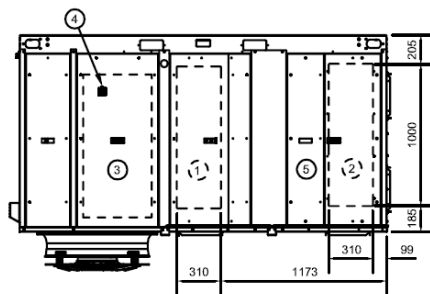
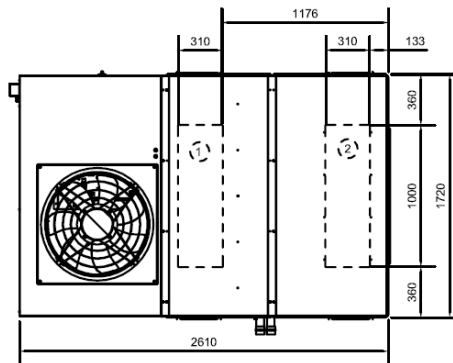
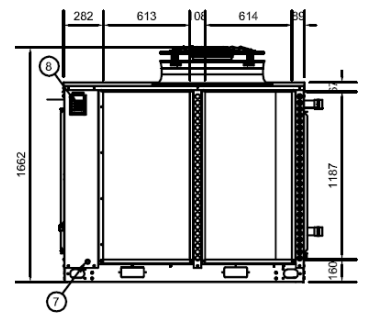
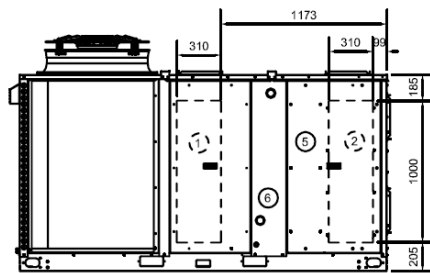
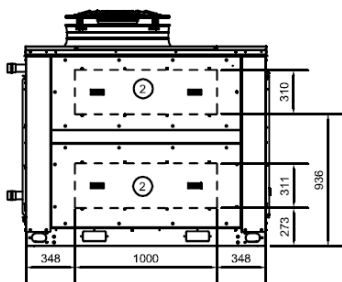
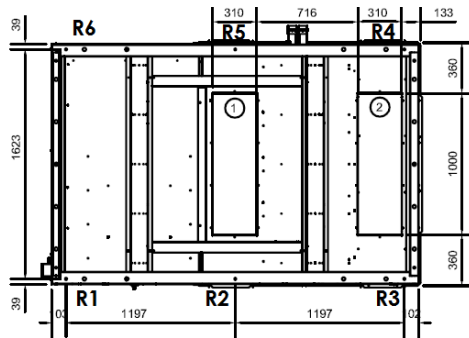

LEGEND	
①	Standard air supply
①	Option air supply
②	Standard air return
②	Option air return
③	Electrical panel board
④	Main switch
⑤	Access for filter replacement
⑥	Condensates drainage INDOOR Ø3/4"
⑦	Ø3/4" couplings, prepared for OUTDOOR drainage.
⑧	Outdoor probe
	25 mm outlet profile

DIMENSIONS

22i-38i models with RCF and VRR

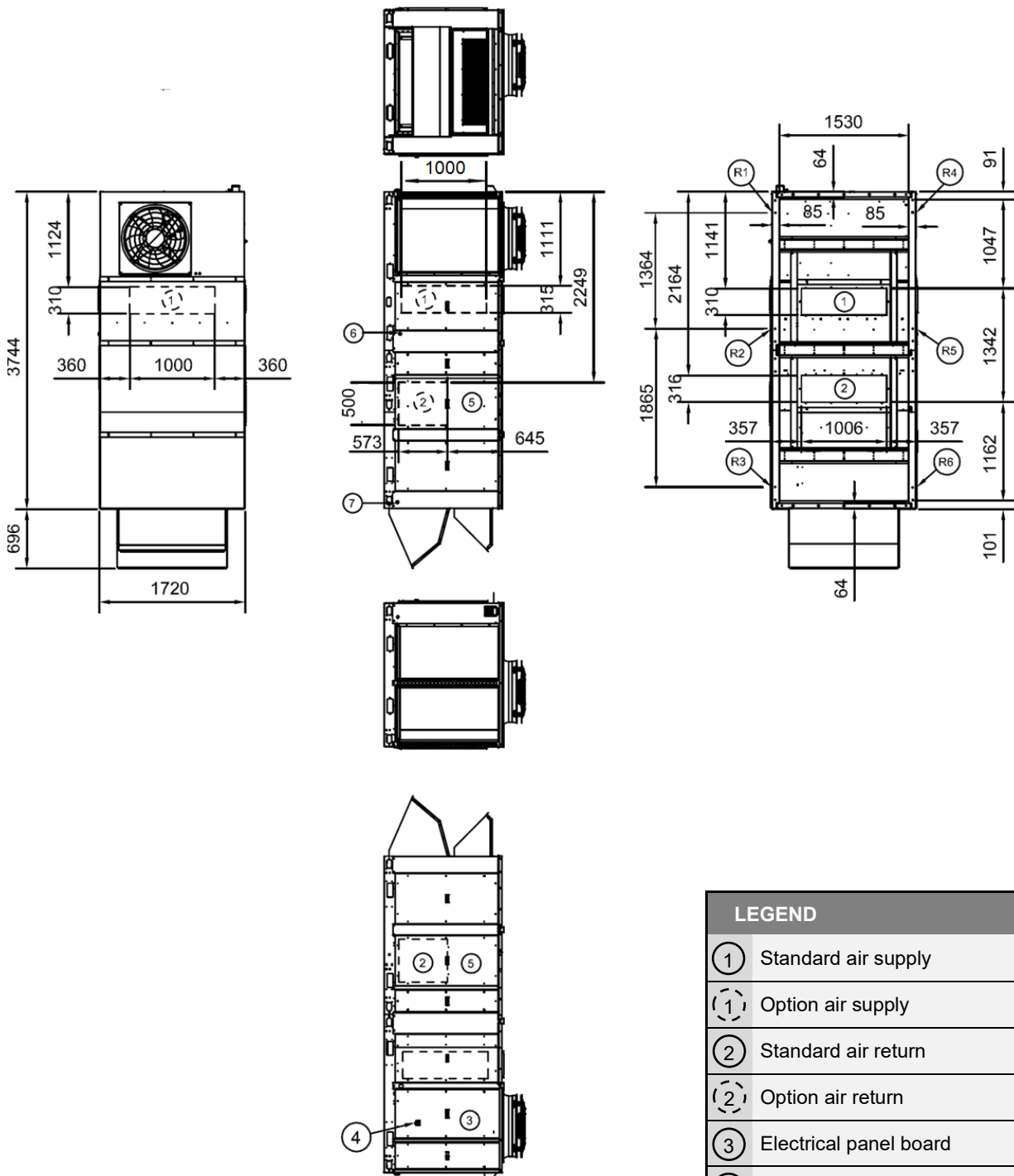

LEGEND	
①	Standard air supply
①	Option air supply
②	Standard air return
②	Option air return
③	Electrical panel board
④	Main switch
⑤	Access for filter replacement
⑥	Condensates drainage INDOOR Ø3/4"
⑦	Ø3/4" condensates drainage, RCF module.
⑧	Outdoor probe
	25 mm outlet profile

DIMENSIONS

45i-90i standard models

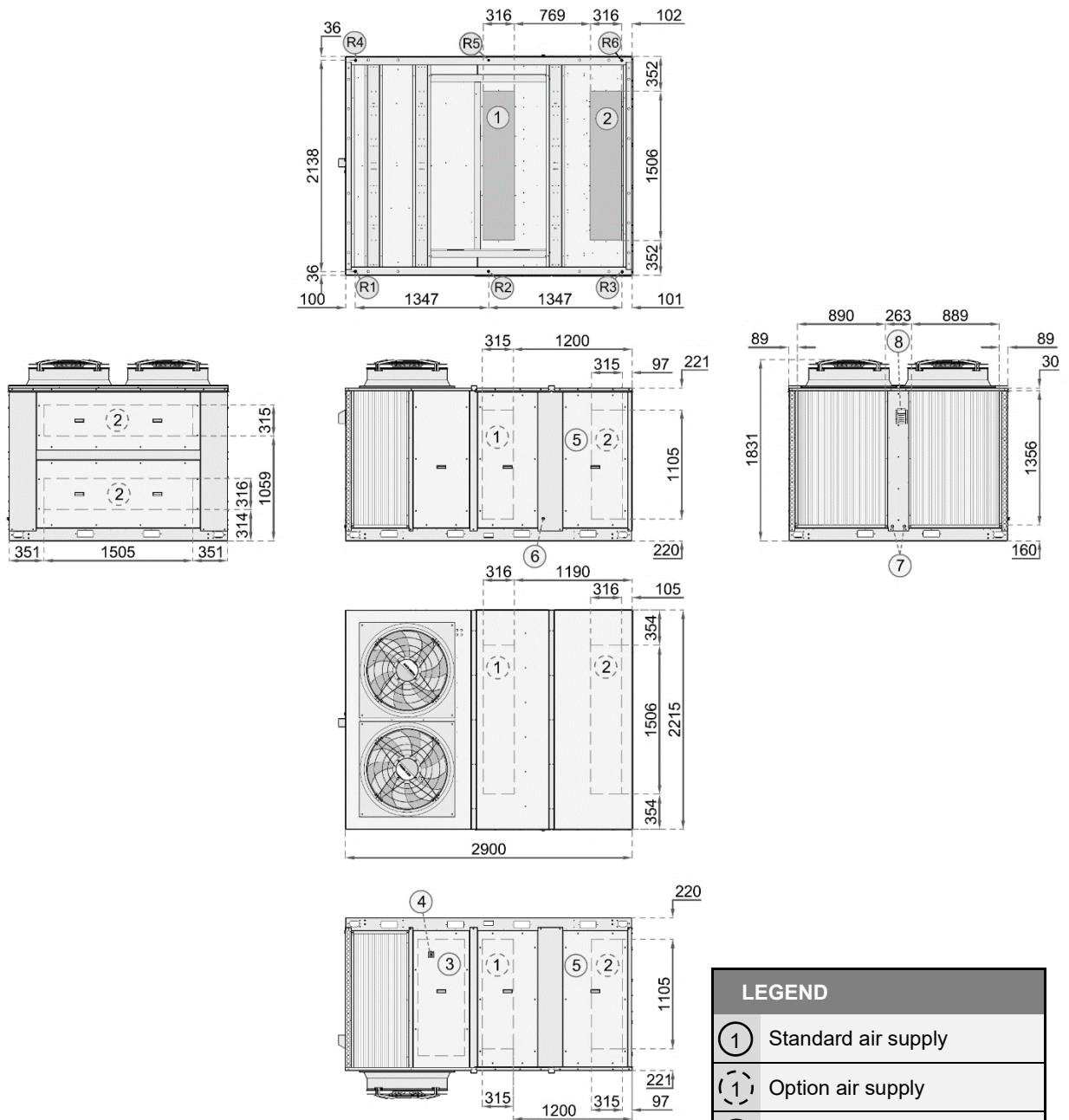

LEGEND	
①	Standard air supply
①	Option air supply
②	Standard air return
②	Option air return
③	Electrical panel board
④	Main switch
⑤	Access for filter replacement
⑥	Condensates drainage INDOOR Ø3/4"
⑦	Ø3/4" couplings, prepared for OUTDOOR drainage.
⑧	Outdoor probe
	25 mm outlet profile

DIMENSIONS

45i-90i models with sandwich panel

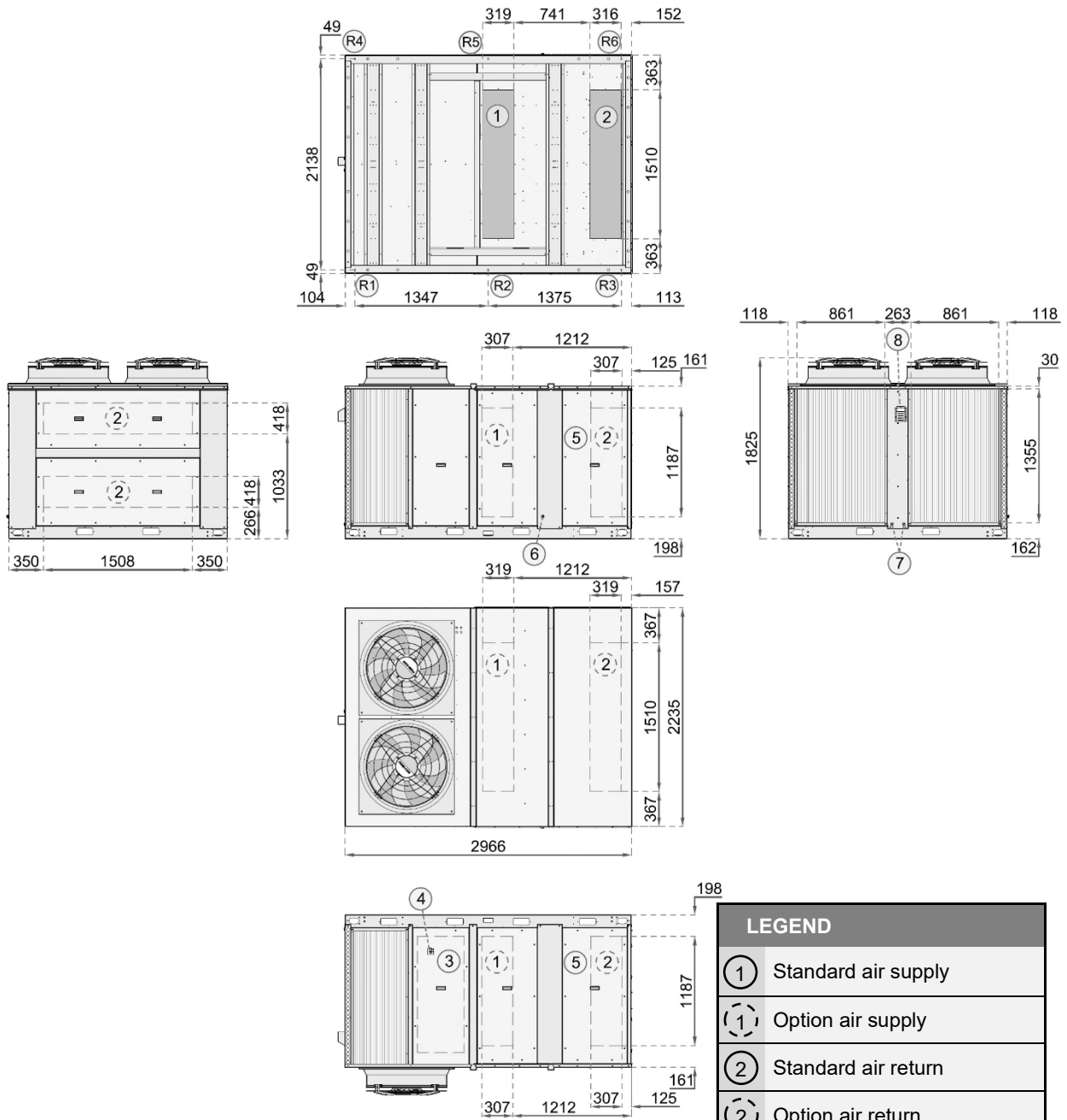

LEGEND	
①	Standard air supply
①	Option air supply
②	Standard air return
②	Option air return
③	Electrical panel board
④	Main switch
⑤	Access for filter replacement
⑥	Condensates drainage INDOOR Ø3/4"
⑦	Ø3/4" couplings, prepared for OUTDOOR drainage.
⑧	Outdoor probe
25 mm outlet profile	

DIMENSIONS

45i-90i models with RCF and VRR

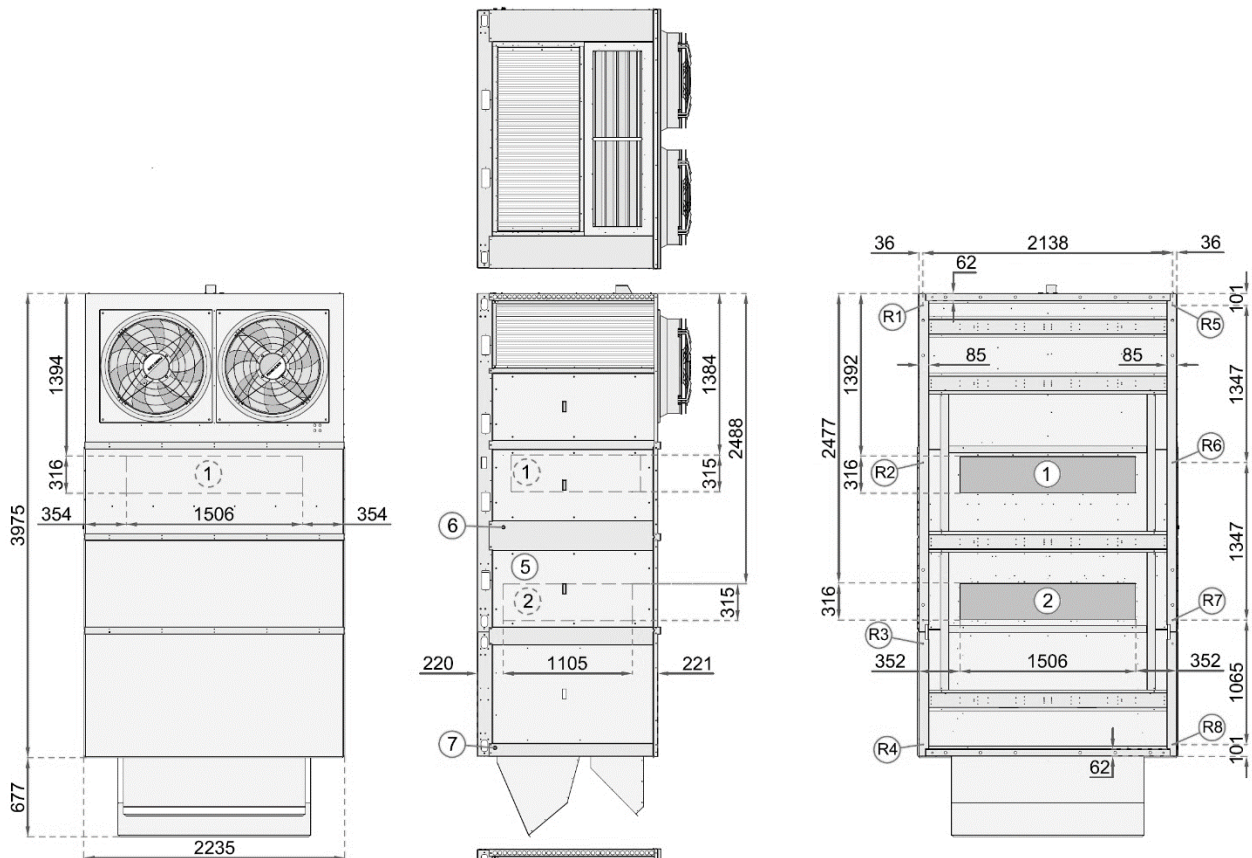

LEGEND	
①	Standard air supply
①	Option air supply
②	Standard air return
②	Option air return
③	Electrical panel board
④	Main switch
⑤	Access for filter replacement
⑥	Condensates drainage INDOOR Ø3/4"
⑦	Ø3/4" condensate drain, recovery module
⑧	Outdoor probe
	25 mm outlet profile

DIMENSIONS

45i-90i models with RCF and VRR with sandwich panel

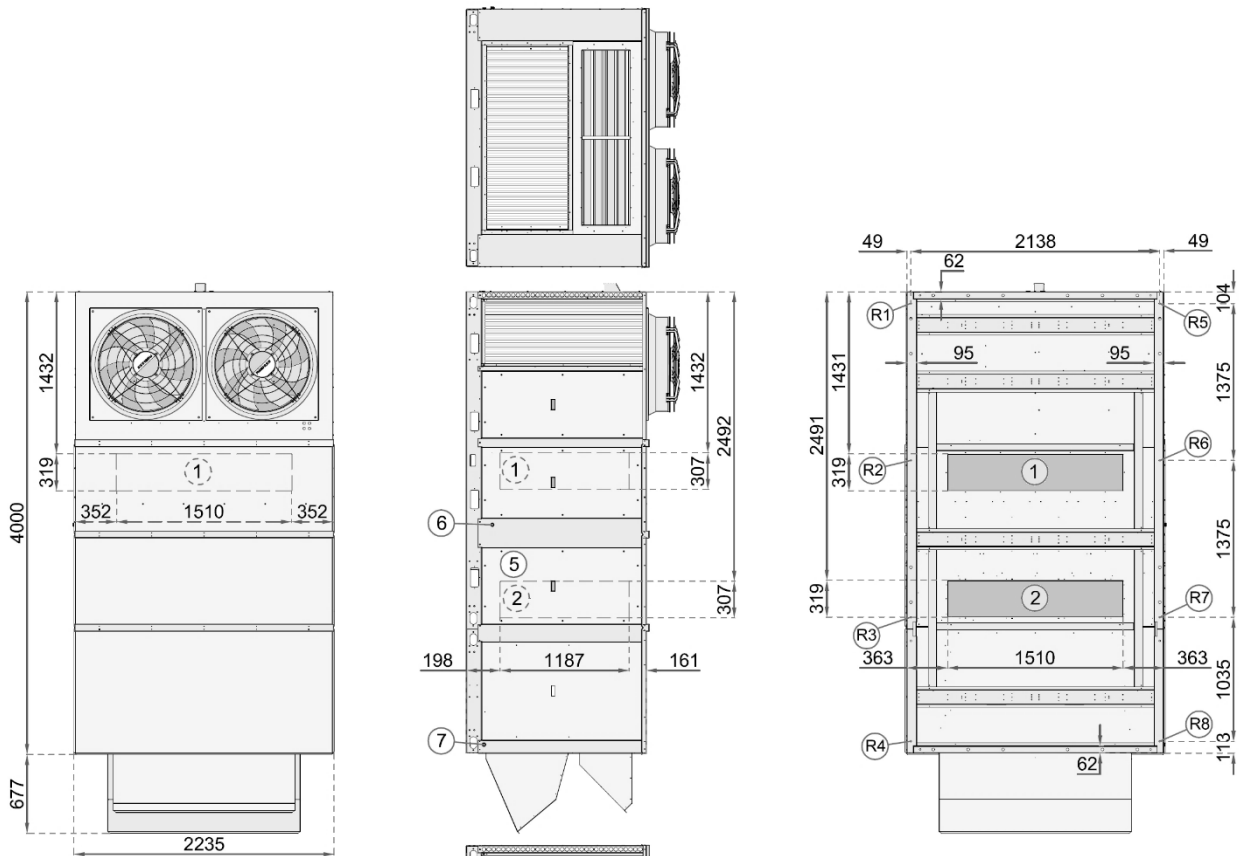

LEGEND	
①	Standard air supply
①	Option air supply
②	Standard air return
②	Option air return
③	Electrical panel board
④	Main switch
⑤	Access for filter replacement
⑥	Condensates drainage INDOOR Ø3/4"
⑦	Ø3/4" condensate drain, recovery module
⑧	Outdoor probe
	25 mm outlet profile

DIMENSIONS

Standard 105 model

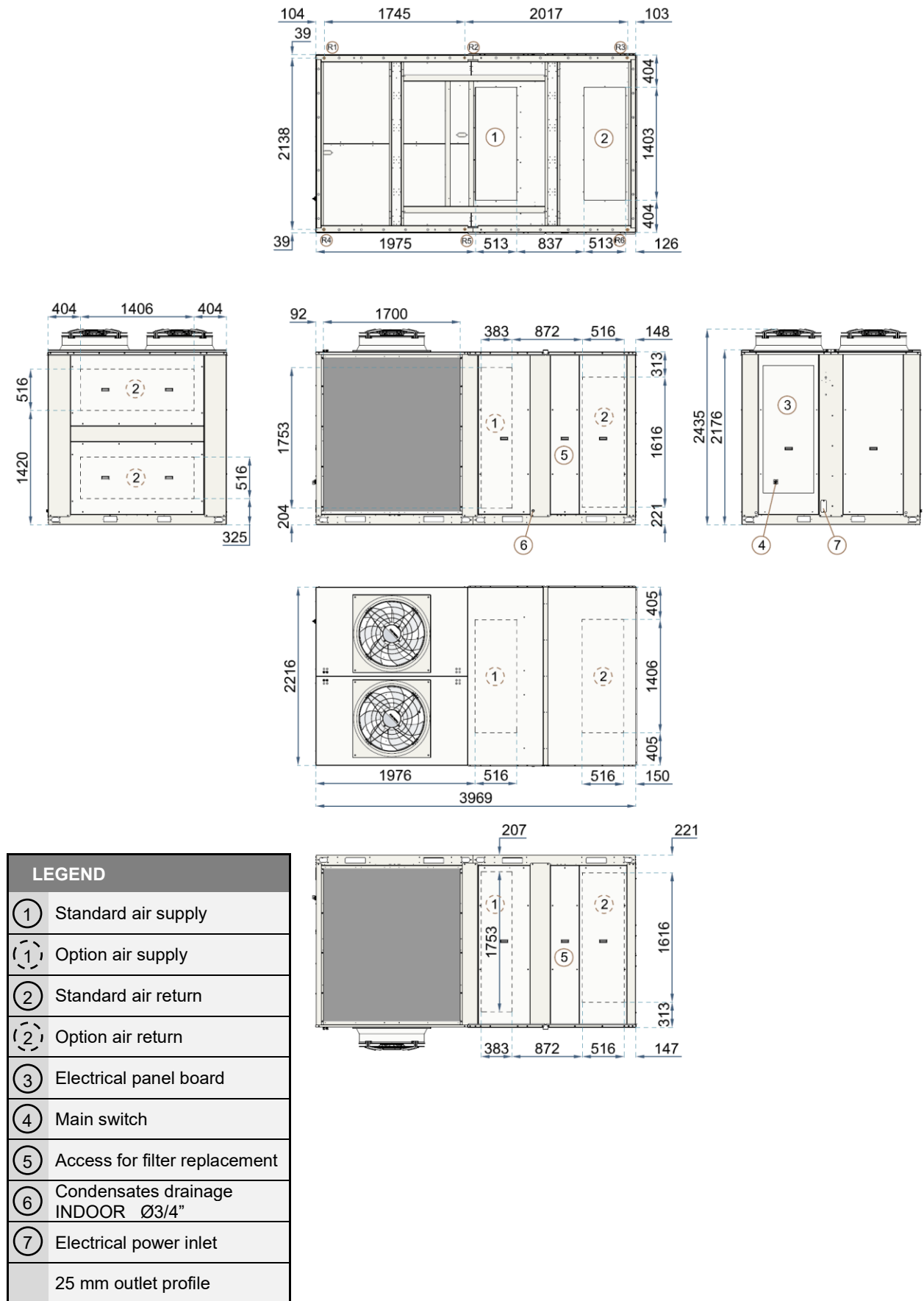

DIMENSIONS

105 RCF and VRR model

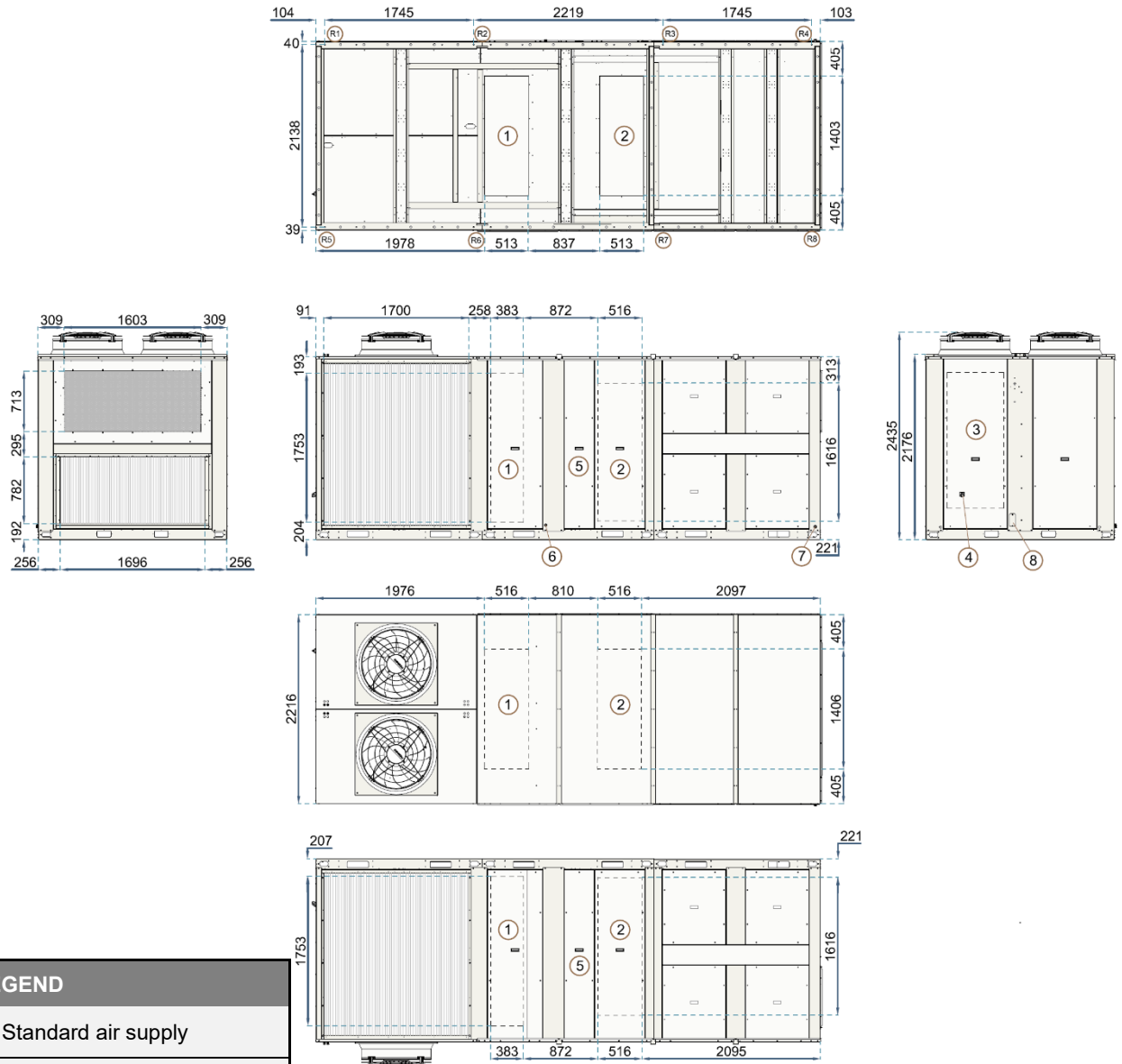

LEGEND	
①	Standard air supply
①	Option air supply
②	Standard air return
②	Option air return
③	Electrical panel board
④	Main switch
⑤	Access for filter replacement
⑥	Condensates drain recovery unit Ø3/4"
⑦	Ø3/4" condensate drain, recovery module
⑧	Electrical power inlet
	25 mm outlet profile

DIMENSIONS

Standard 125-145 models

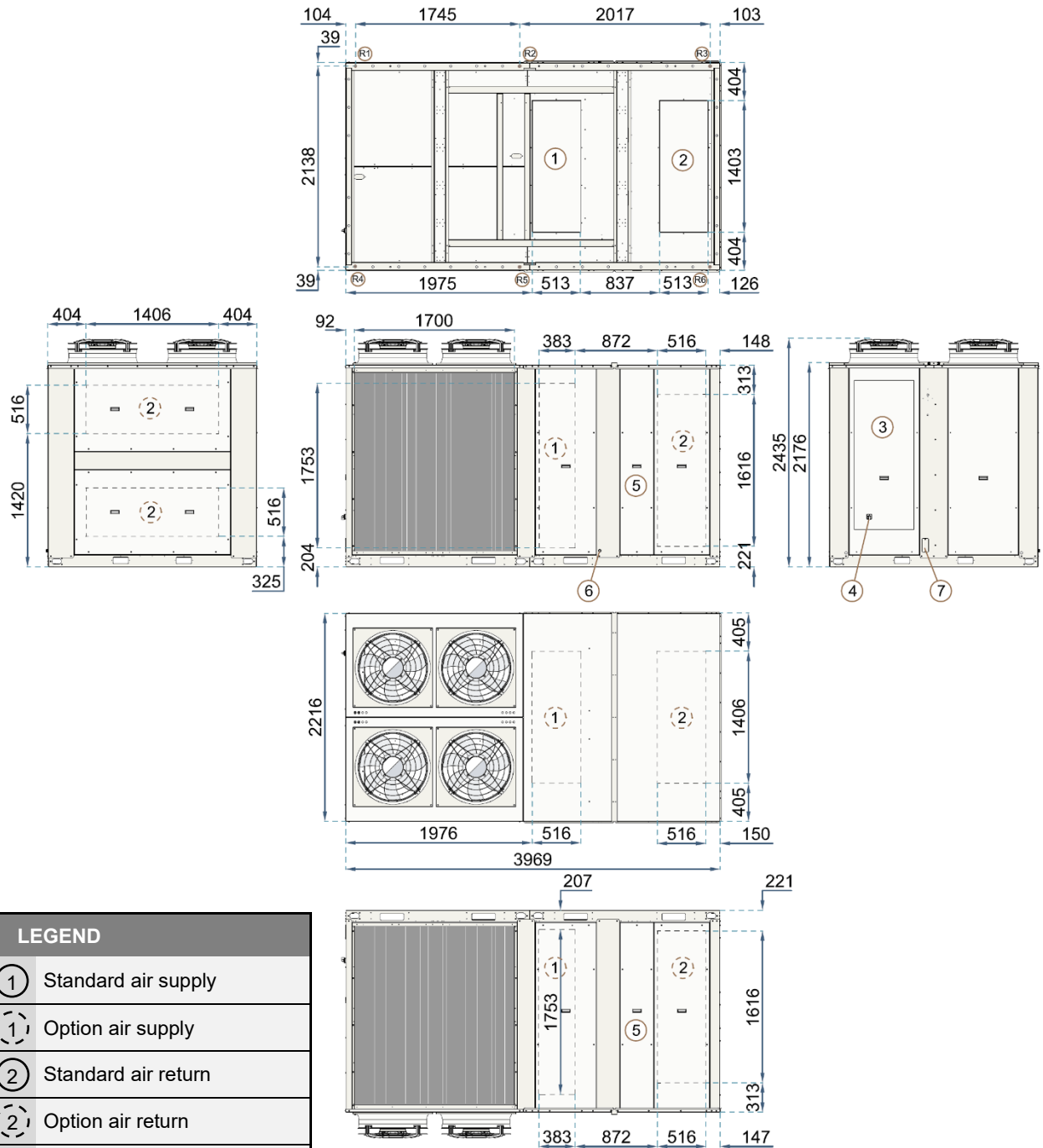

LEGEND	
①	Standard air supply
①	Option air supply
②	Standard air return
②	Option air return
③	Electrical panel board
④	Main switch
⑤	Access for filter replacement
⑥	Condensates drainage INDOOR Ø3/4"
⑦	Electrical power inlet
	25 mm outlet profile

DIMENSIONS

125-145 models with RCF and VRR

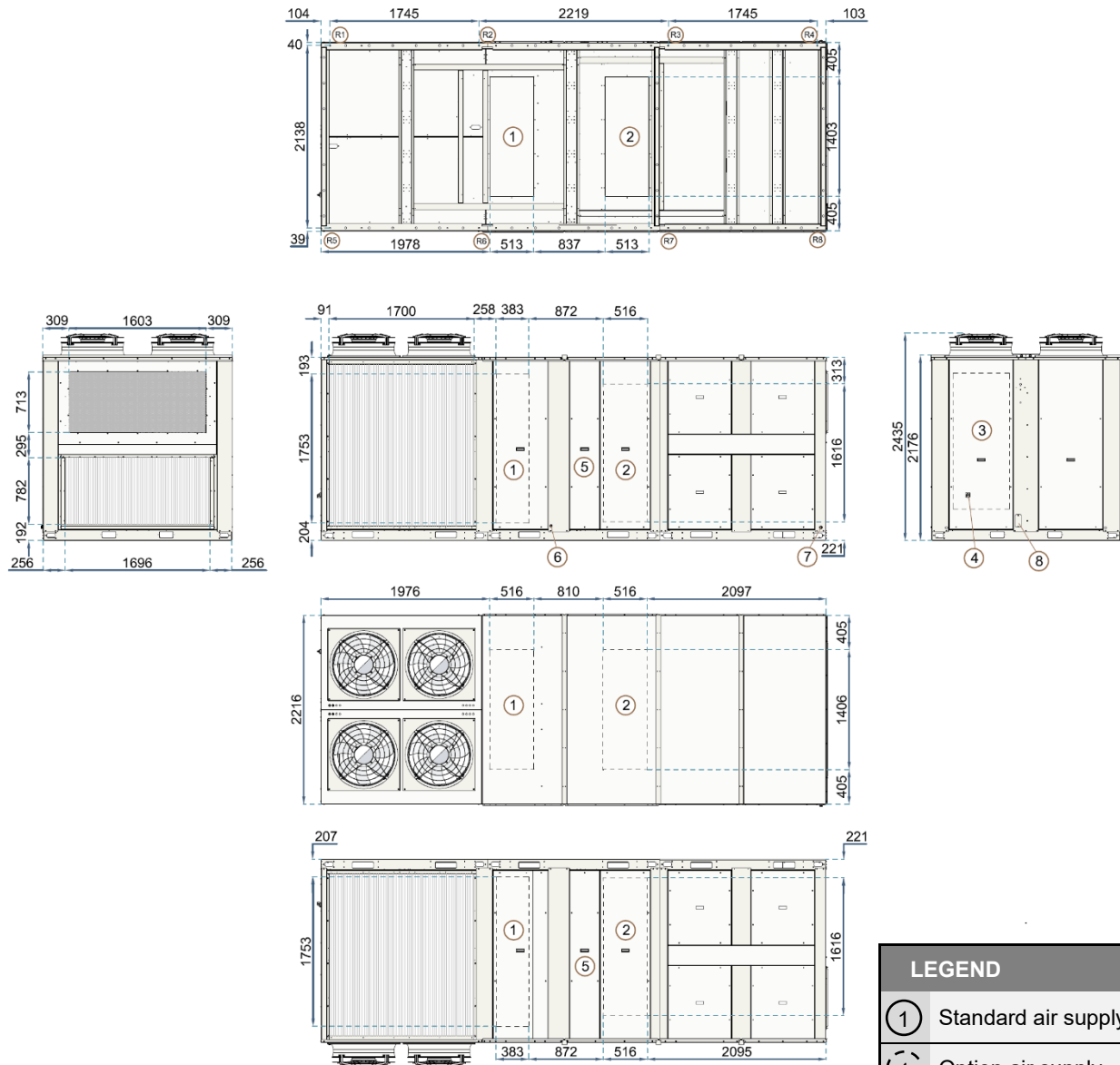

LEGEND	
①	Standard air supply
①	Option air supply
②	Standard air return
②	Option air return
③	Electrical panel board
④	Main switch
⑤	Access for filter replacement
⑥	Condensates drainage, recovery unit Ø3/4"
⑦	Ø3/4" condensate drain, recovery module
⑧	Electrical power inlet
25 mm outlet profile	

DIMENSIONS

Standard 175-210 models

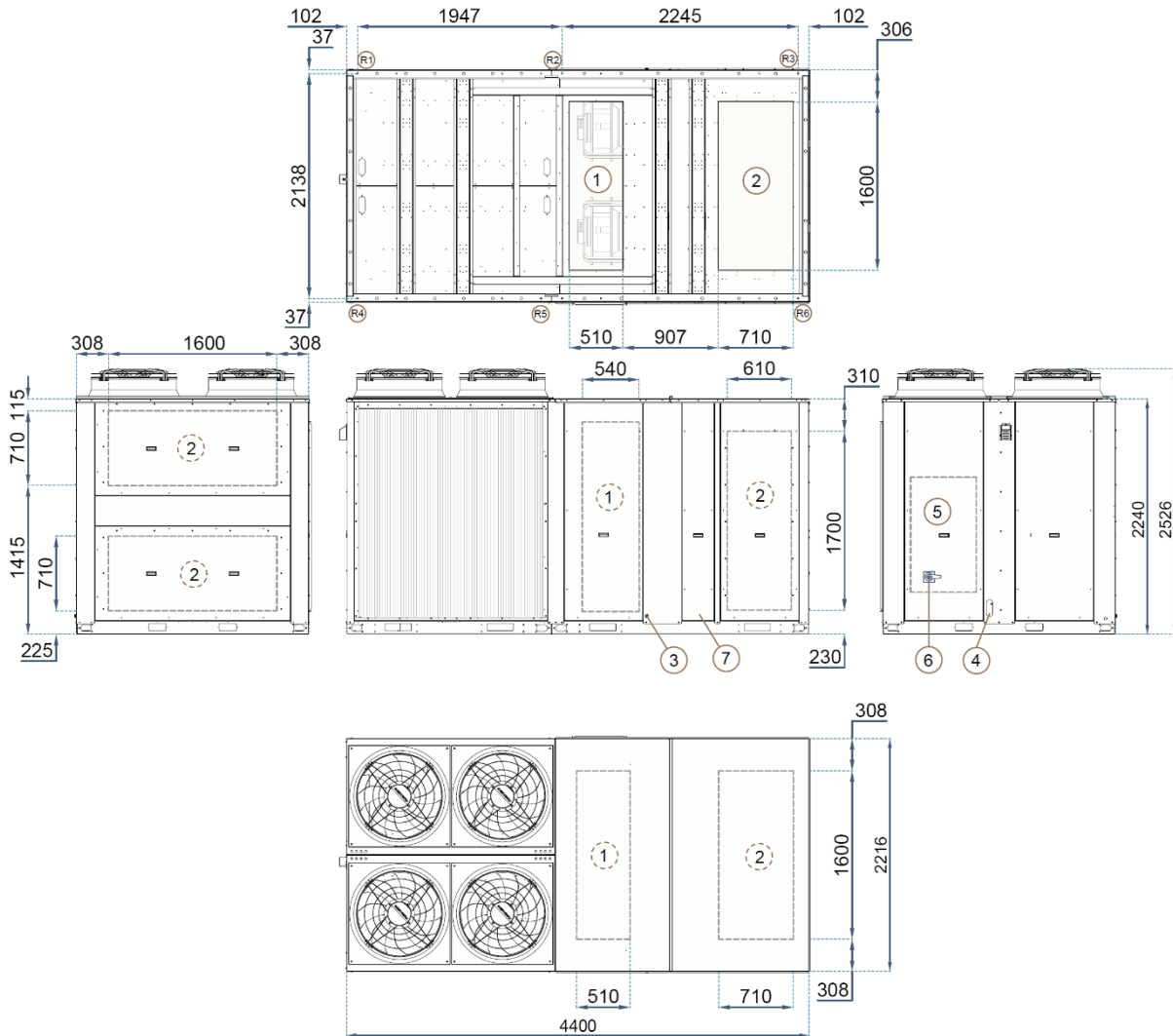

LEGEND	
①	Standard air supply
①	Option air supply
②	Standard air return
②	Option air return
③	Condensates drainage INDOOR Ø3/4"
④	Electrical power inlet
⑤	Electrical panel board
⑥	Main switch
⑦	Access for filter replacement
	25 mm outlet profile

DIMENSIONS

175-210 models with RCF and VRR

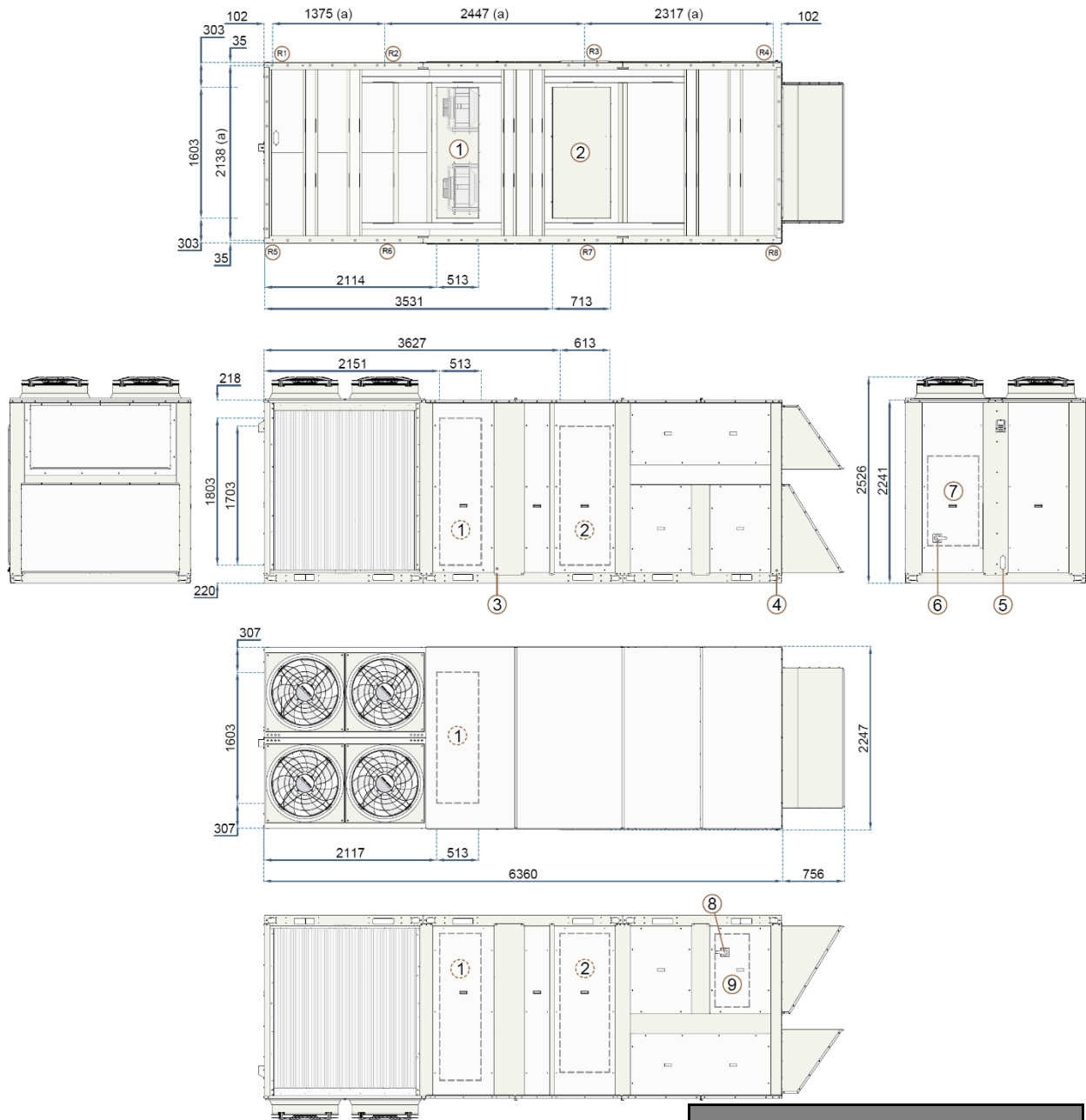

LEGEND	
①	Standard air supply
①	Option air supply
②	Standard air return
②	Option air return
③	Condensates removal INDOOR Ø3/4"
④	Electrical power inlet
⑤	Electrical panel board
⑥	Main switch
⑦	Access for filter replacement
⑧	Recovery unit switch
⑨	Recovery unit electrical panel board
25 mm outlet profile	
(a) Support point Ø15	

REFRIGERATION DIAGRAMS

22i- 38i models

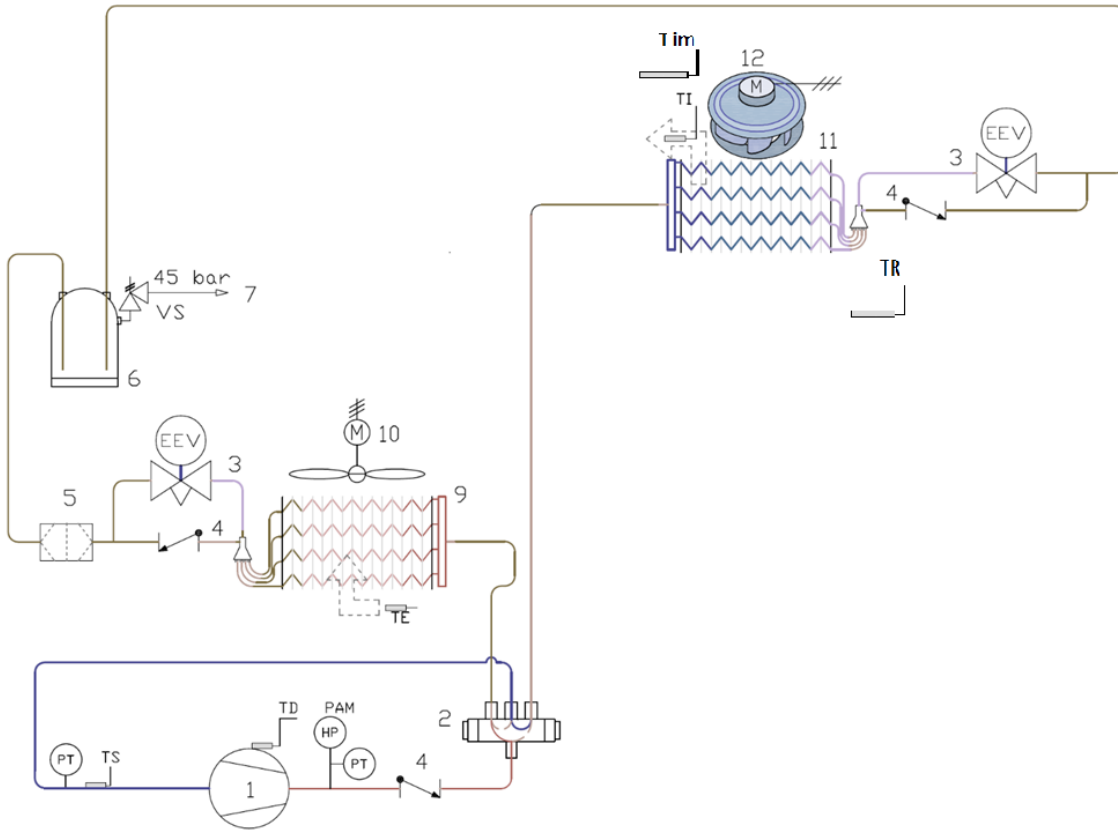

- 1 - Inverter compressor
- 2 - 4-way valve
- 4 - Check valve
- 6 - Liquid tank
- 10 - Outdoor fan
- 12 - Indoor fan
- PAM- Manual high pressure switch
- HP - High pressure switch
- TE - Outdoor temperature
- TS - Temperature probe
- Tim - Air supply temperature probe

- PT - Pressure transducer
- TD - Discharge temperature
- TI - Indoor temperature
- VS - Security valve
- TR - Return temperature probe

RCF circuit

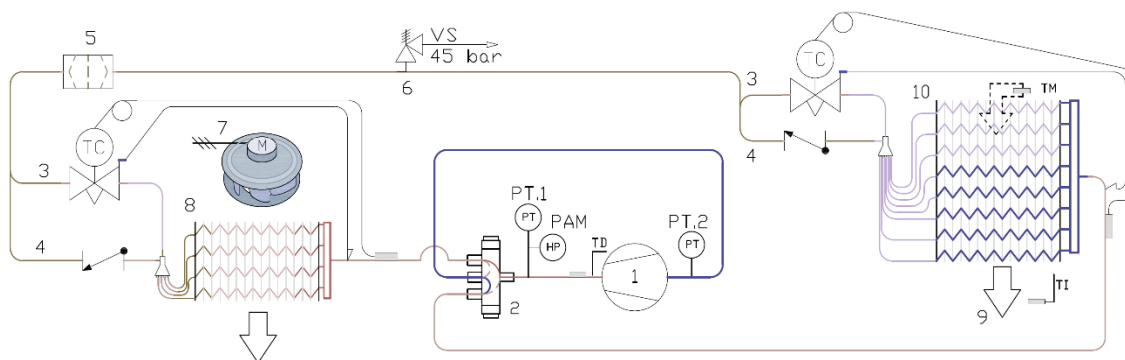

- 1 - Compressor (RCF circuit)
- 2 - 4-way valve
- 4 - Check valve
- 6 - Relief valve
- 8 - Outdoor coil with fins - RCF
- 10 - Indoor coil with fins - RCF

- 3 - Thermostatic expansion valve
- 5 - Filter (Biflow)
- 7 - New air fan
- 9 - Air to the main indoor coil

- HP - High pressure switch
- PT - Pressure transducer
- TI - Indoor temperature (Option)
- VS - Security valve

- PAM- Manual high pressure switch
- TD - Discharge temperature
- TM - Air mixture temperature

REFRIGERATION DIAGRAMS

45i- 90i models

MAIN circuit

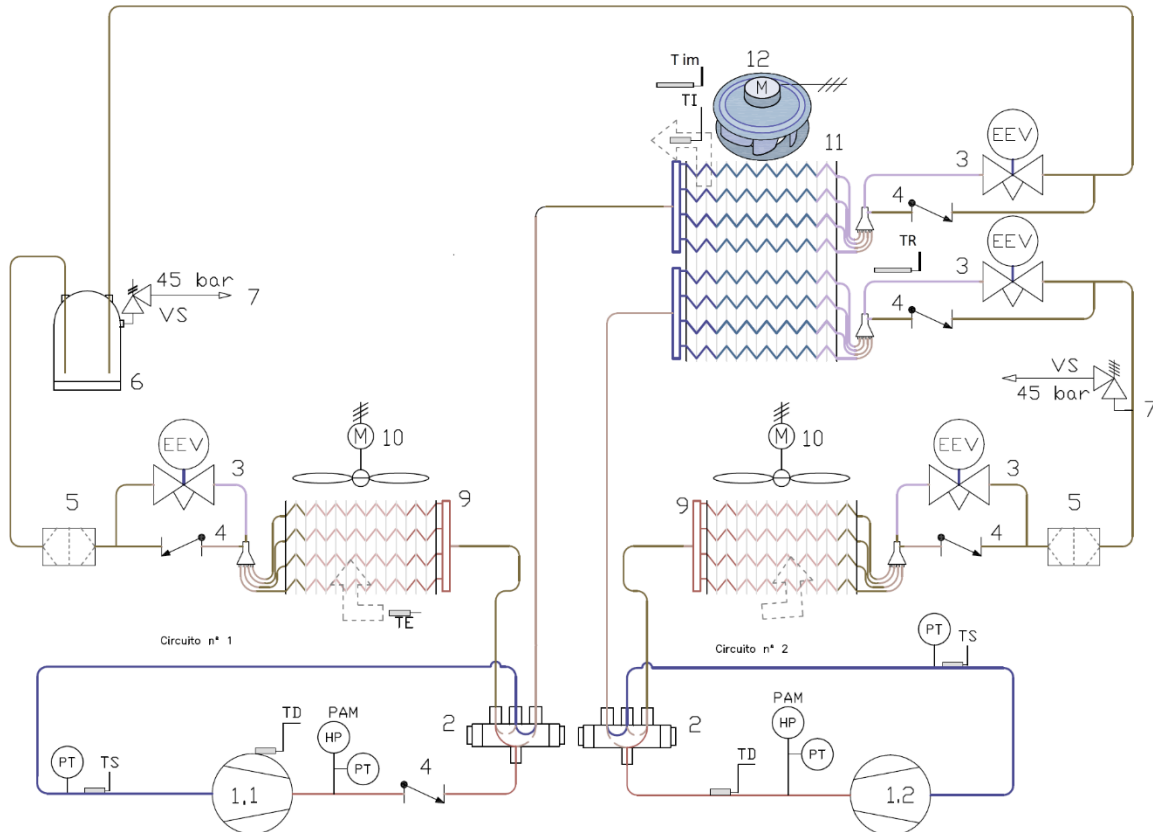

- 1.1 - Inverter compressor (Circuit n° 1)
- 2 - 4-way valve
- 4 - Check valve
- 6 - Liquid tank
- 10 - Outdoor fan
- 12 - Indoor fan
- PAM- Manual high pressure switch
- HP - High pressure switch
- TE - Outdoor temperature
- TS - Temperature probe
- PAM- Manual high pressure switch
- Tim - Air supply temperature probe

- 1.2 - Compressor (Circuit n° 2)
- 3 - Electronic expansion valve
- 5 - Filter (Biflow)
- 7 - Relief valve
- 9 - Outdoor coil with fins
- 11 - Indoor coil with fins
- PT - Pressure transducer
- TD - Discharge temperature
- TI - Indoor temperature (Option)
- VS - Security valve
- PT - Pressure transducer
- TR - Return temperature probe

RCF circuit

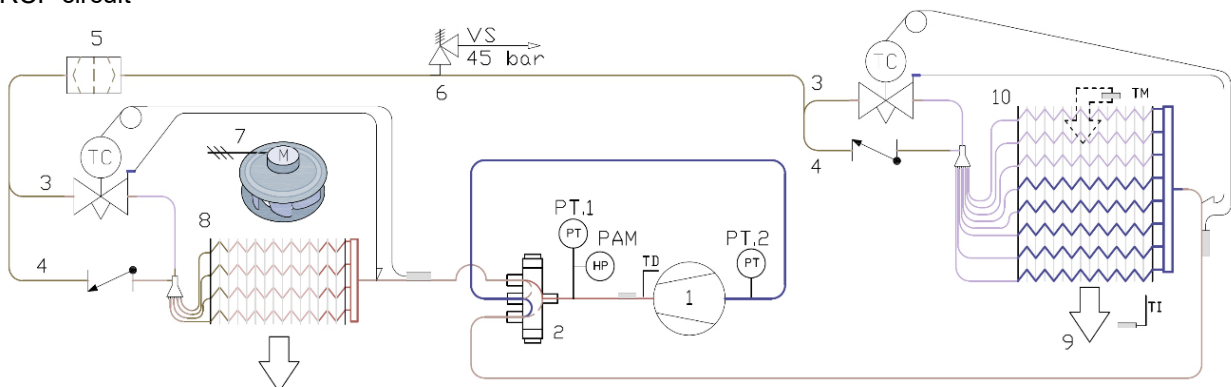

- 1 - Compressor (RCF circuit)
- 2 - 4-way valve
- 4 - Check valve
- 6 - Relief valve
- 8 - Outdoor coil with fins - RCF
- 10 - Indoor coil with fins - RCF

- 3 - Thermostatic expansion valve
- 5 - Filter (Biflow)
- 7 - New air fan
- 9 - Air to the main indoor coil

- HP - High pressure switch
- PT - Pressure transducer
- TI - Indoor temperature (Option)
- VS - Security valve

- PAM- Manual high pressure switch
- TD - Discharge temperature
- TM - Air mixture temperature

REFRIGERATION DIAGRAMS

105- 145 models

MAIN circuit

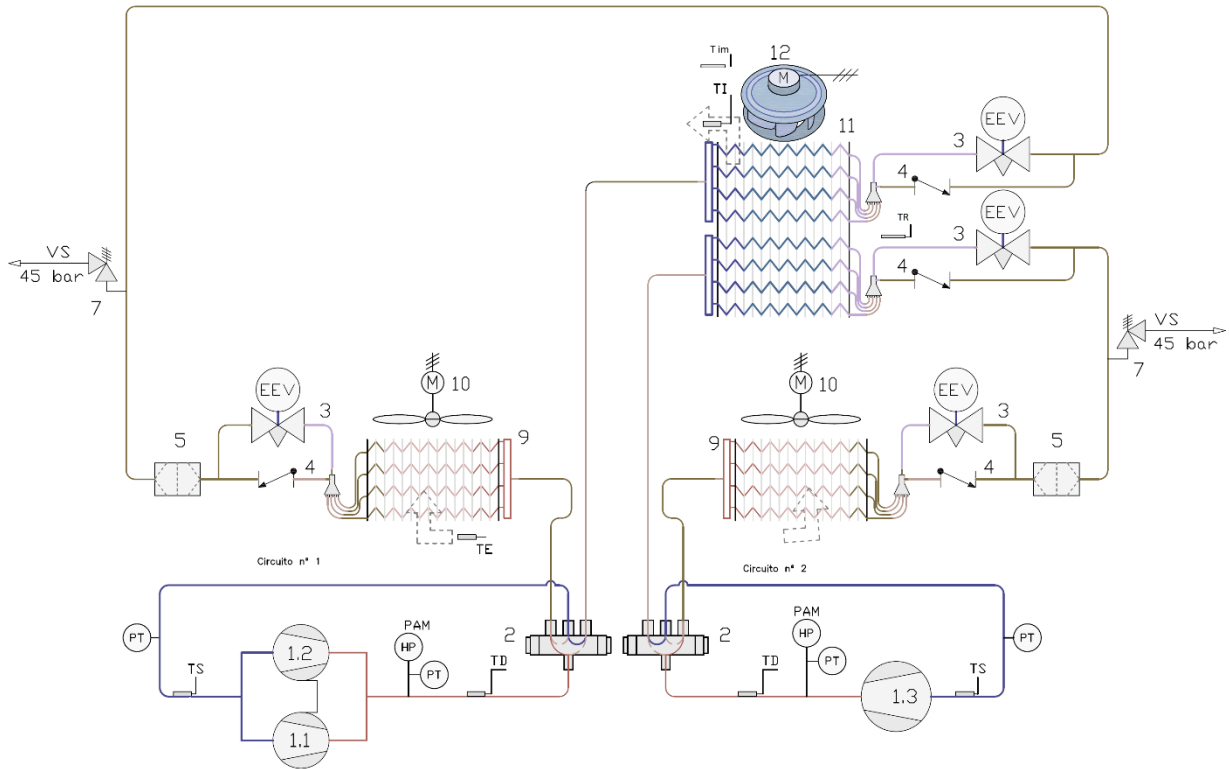

- 1.1 - Compressor + 1.2 Tandem (Circuit n° 1)
- 2 - 4-way valve
- 4 - Check valve
- 6 - Liquid tank
- 10 - Outdoor fan
- 12 - Indoor fan

- 1.3 - Compressor (Circuit n° 2)
- 3 - Electronic expansion valve
- 5 - Filter (Biflow)
- 7 - Relief valve
- 9 - Outdoor coil with fins
- 11 - Indoor coil with fins

- PAM- Manual high pressure switch
- HP - High pressure switch
- TE - Outdoor temperature
- TS - Temperature probe
- Tim - Air supply temperature probe

- PT - Pressure transducer
- TD - Discharge temperature
- TI - Indoor temperature (Option)
- VS - Security valve
- TR - Return temperature probe

RCF circuit

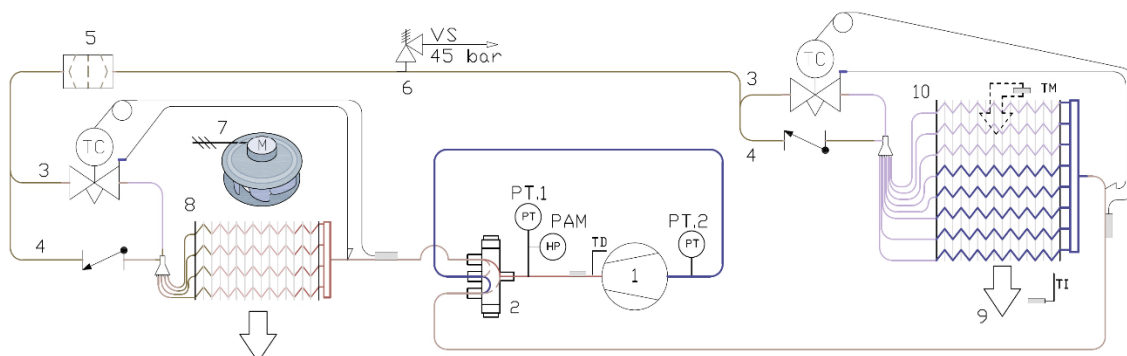

- 1 - Compressor (RCF circuit)
- 2 - 4-way valve
- 4 - Check valve
- 6 - Relief valve
- 8 - Outdoor coil with fins - RCF
- 10 - Indoor coil with fins - RCF

- 3 - Thermostatic expansion valve
- 5 - Filter (Biflow)
- 7 - New air fan
- 9 - Air to the main indoor coil

- HP - High pressure switch
- PT - Pressure transducer
- TI - Indoor temperature (Option)
- VS - Security valve

- PAM- Manual high pressure switch
- TD - Discharge temperature
- TM - Air mixture temperature

REFRIGERATION DIAGRAMS

175- 210 models

MAIN circuit

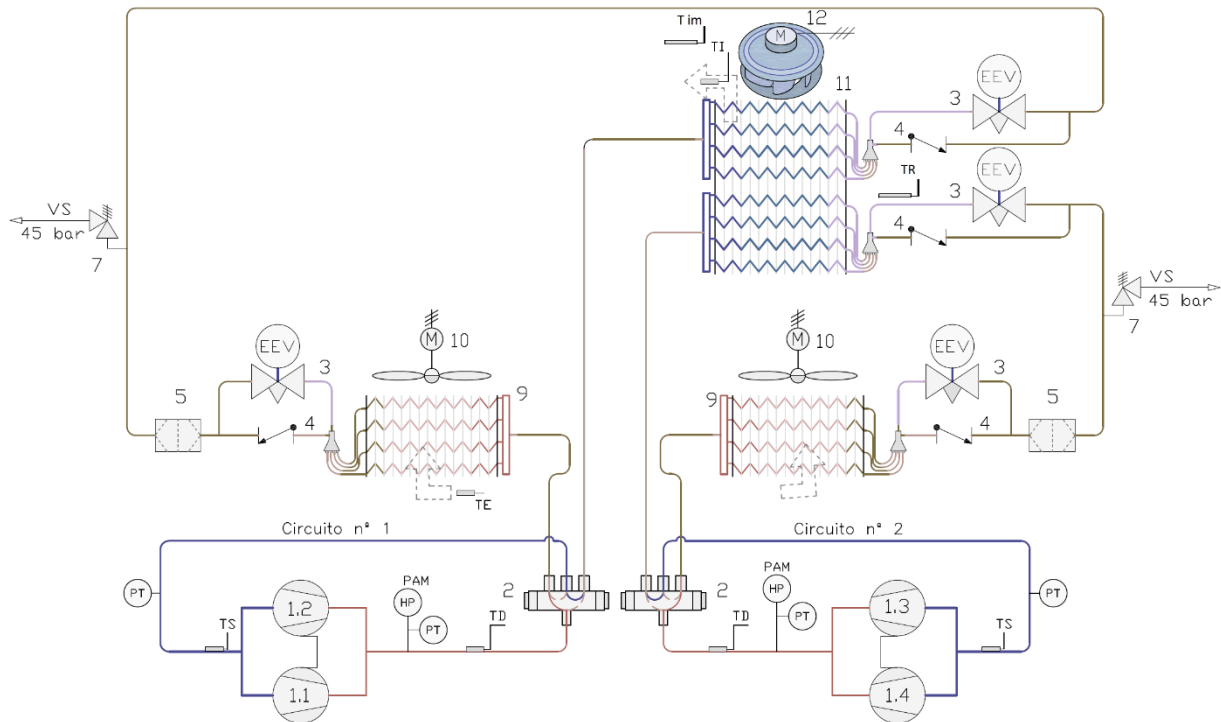

- 1.1 - Compressor + 1.2 Tandem (Circuit n° 1)
- 2 - 4-way valve
- 4 - Check valve
- 6 - Liquid tank
- 7 - Relief valve
- 10 - Outdoor fan
- 12 - Indoor fan

- 1.3 - Compressor + 1.4 Tandem (Circuit n° 2)
- 3 - Electronic expansion valve
- 5 - Filter (Biflow)
- 9 - Outdoor coil with fins
- 11 - Indoor coil with fins

- PAM- Manual high pressure switch
- HP - High pressure switch
- TE - Outdoor temperature
- TS - Temperature probe
- Tim - Air supply temperature probe

- PT - Pressure transducer
- TD - Discharge temperature
- TI - Indoor temperature (Option)
- VS - Security valve
- TR - Return temperature probe

RCF circuit

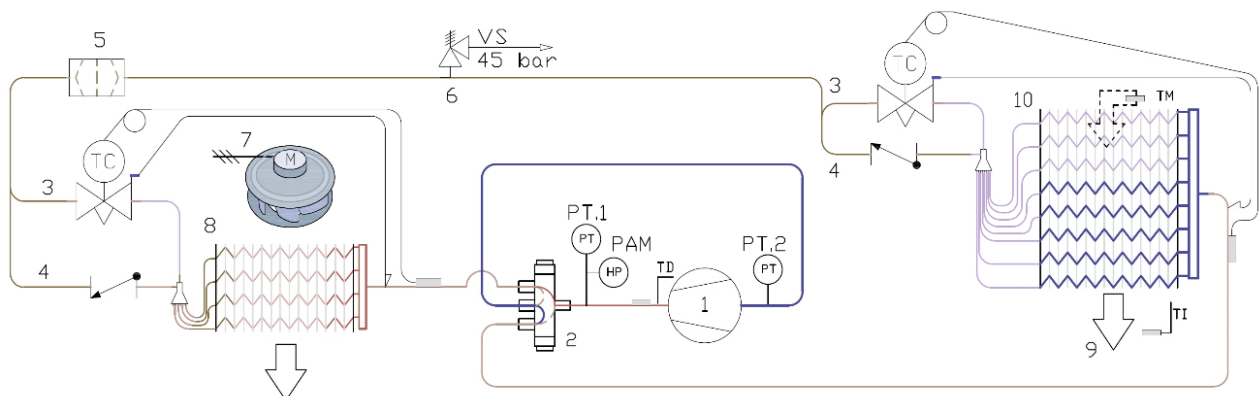

- 1 - Compressor (RCF circuit)
- 2 - 4-way valve
- 4 - Check valve
- 6 - Relief valve
- 8 - Outdoor coil with fins - RCF
- 10 - Indoor coil with fins - RCF

- 3 - Thermostatic expansion valve
- 5 - Filter (Biflow)
- 7 - New air fan
- 9 - Air to the main indoor coil

- HP - High pressure switch
- PT - Pressure transducer
- TI - Indoor temperature (Option)
- VS - Security valve

- PAM- Manual high pressure switch
- TD - Discharge temperature
- TM - Air mixture temperature

INSTALLATION

INSTALLATION SITE

- Read and comply with the local rules and regulations applying to the installation of air conditioning systems.
- Choose a clean place without dust nor debris.
- Remain within the appropriate service area prepared for the equipment.
- Verify that the ground or the structure prepared for the equipment is strong enough to support its weight during operation.
- Install shock absorbers throughout the installation to prevent the transmission of noise and vibration.
- Check that the direction of the sound level will not disturb anybody.

UNIT SETTLEMENT

- Make sure that the equipment is levelled correctly.
- The bed frame shall be strong enough to support the unit weight.
- Make sure that after settlement the unit drain is working properly.

WATER DRAIN

- The indoor drain unit (of condensate water) has a 3/4" gas (ISO 228-1, BSPP) male connection.
- The condensate drain pipe diameter should be equal or larger than the unit connection depending on the line length and the general building configuration.
- The drainage line should be inclined by minimum 2% for a proper water evacuation.
- When drain line is exposed to air temperatures below 0 degrees, it is necessary to cover with thermal insulation or electrical heating wire to avoid water freezing and tube damage.
- It is convenient to install the drain trap with proper dimensions (see diagram).

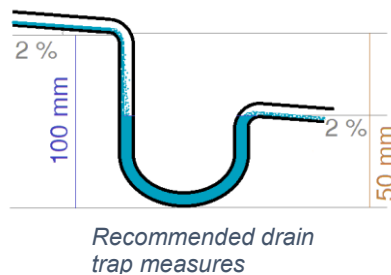

Drainage – internal side

The internal coil is equipped from factory with an inclined condensates drain pan to avoid excessive water accumulation and the following growth of bacteria.

Drainage – external side

The Kubic models are fitted with water drain connections in each external coil to avoid excessive accumulation of condensate in the compressor area of the unit.

It is recommended to use a drain trap at each outlet to ease evacuation. However the complete the drainage of all the condensates will not be guaranteed.

To ensure the complete drainage of the condensates through the drain trap you will need to order the external condensates pan available as an option.

AIR DUCTS

The air duct dimensions will be determined according to the air flow and the available static pressure of the unit. Qualified technicians shall design them. An incorrect design may reduce the unit's performance and may be a hindrance when access to the unit for maintenance operations is needed (in particular where there is only one possible access).

Use ducts made of non-inflammable material in order to avoid any risk of fire because of the deflagration of gases. It is advisable to use insulated metal ducts.

Use flexible conduits to connect air ducts to the unit so as to avoid vibration and noise transmission.

INSTALLATION

Installation of the outdoor sensor

Pay attention to the following:

- Install the sensors on the panel using the holes on the container.
- Avoid direct exposure to the sun and protect it from inclement weather (rain and hail).
- Install the sensor preferably on the northern outside wall of the building.
- Do not make holes in the container that could compromise the IP protection.
- To maintain the IP65 degree of protection, the connection must be made with a multicore cable with an external sheathing of 8 mm max.
- The use of shielded cables is recommended. The signal cables must not be housed near power cables or cables with loads of 230 to 400 Vac, nor near control switch cables. This reduces the risks of disturbance coupling and, therefore, measurement errors caused by electromagnetic coupling.
- Provide at least a main insulation related to the mains power supply for the controller where the probe is connected; if the sensor endcap is accessible to the users, double insulation must be provided.
- For wiring, a multicore cable with 3 to 5 wires with a maximum section of 1.5 mm² is recommended.

To prevent errors due to the power supply current, supplementary power supply can be used from an external transformer. The transformer must not be earthed and can be located in the regulator panel. In this case, the supply connection uses two wires separated from the signal wires (4 total). In installations with several probes, each one must be supplied by its own transformer. In this situation, the max connection distance can be 100m with 1.5 mm² section cables to reduce the noise due to the supply connection.

Output at 4 to 20 mA: the maximum distance is 200 m.

Pay careful attention during the electrical connection phase (see connection diagrams).

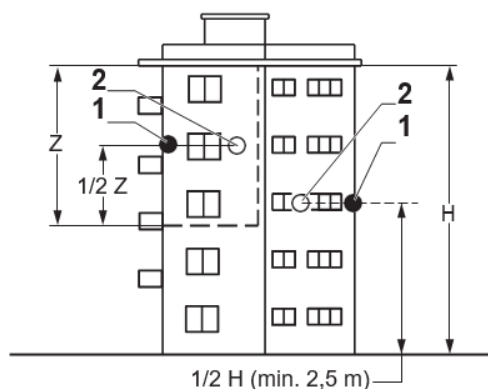
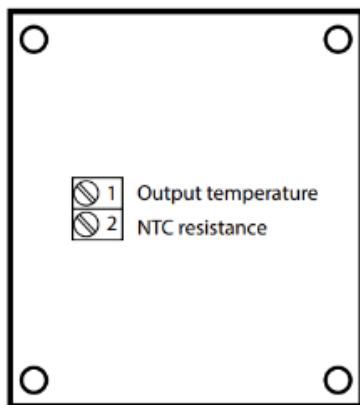

- 1 Recommended location
- 2 Possible location

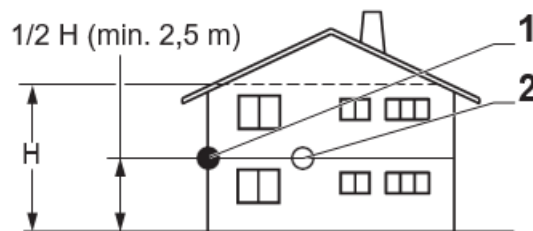

- H Living area to be monitored by the sensor
- Z Living area to be monitored by the sensor

INSTALLATION

Unsuitable locations

Avoid installing the outdoor sensor in a location with the following characteristics:

- Hidden by part of the building (balcony, roof, etc.).
- Close to a heat source that may interfere (sun, chimney, ventilation grille, etc.).

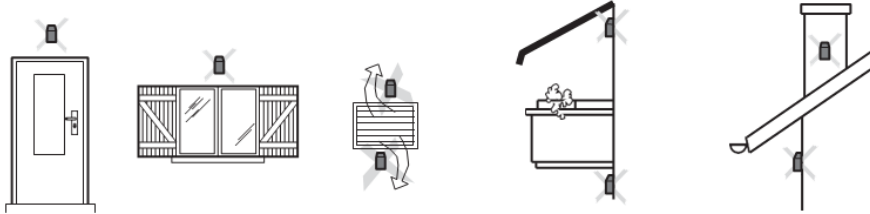

INSTALLATION

SERVICE AREA

The following measures shall be respected to ensure the proper operation of the unit.

22i to 38i models

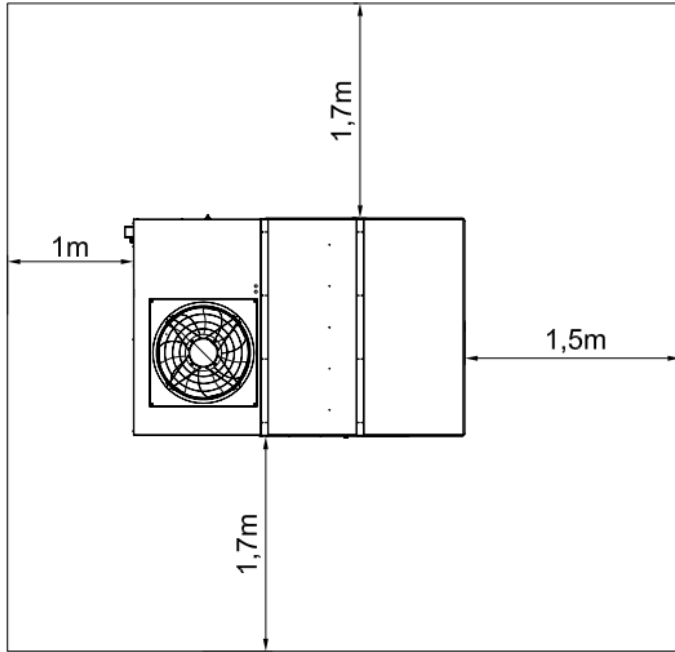

22i to 38i models with RCF

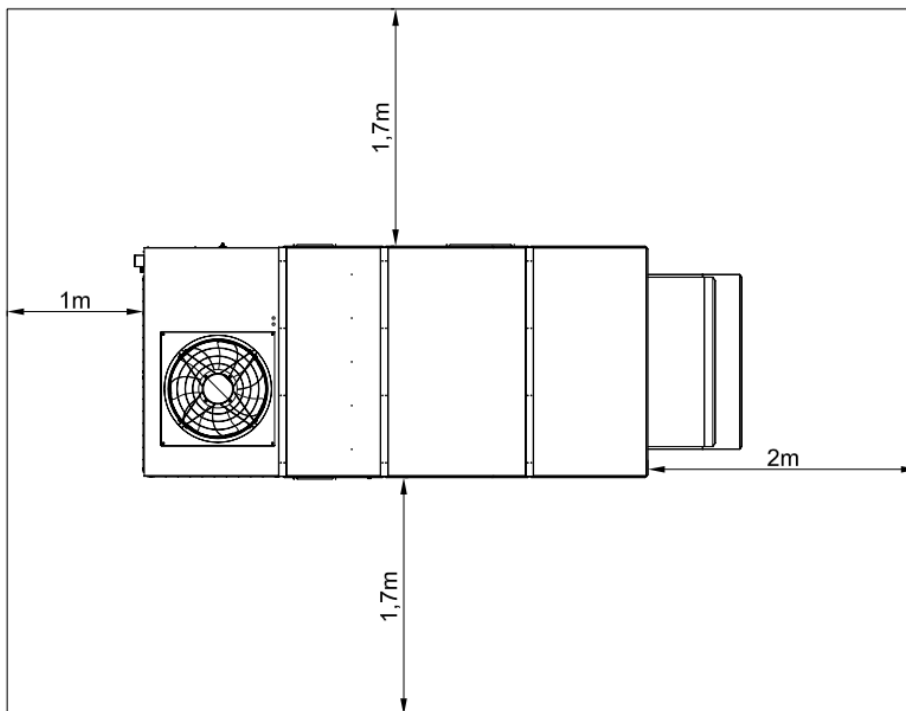

INSTALLATION SERVICE AREA

45i to 90i models

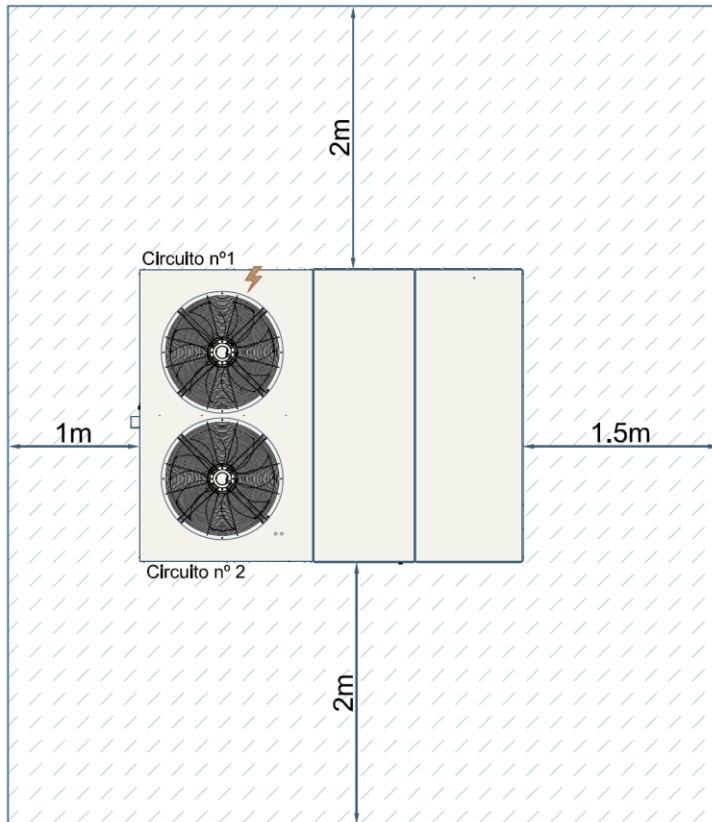

45i to 90i models with RCF

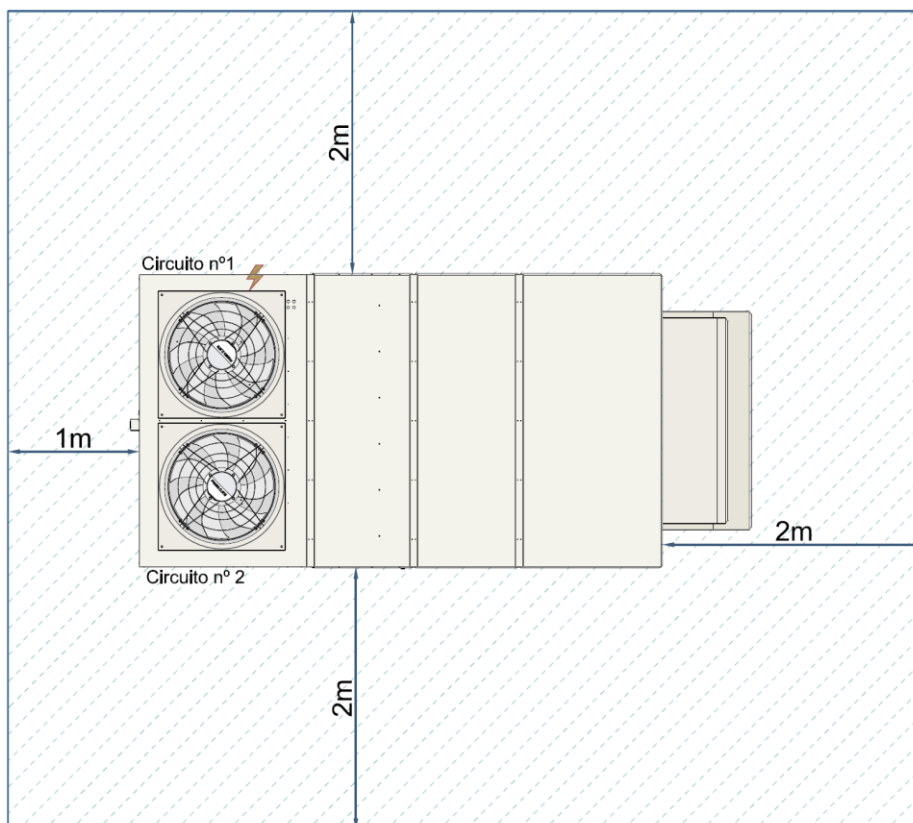

INSTALLATION - SERVICE AREA

105 model

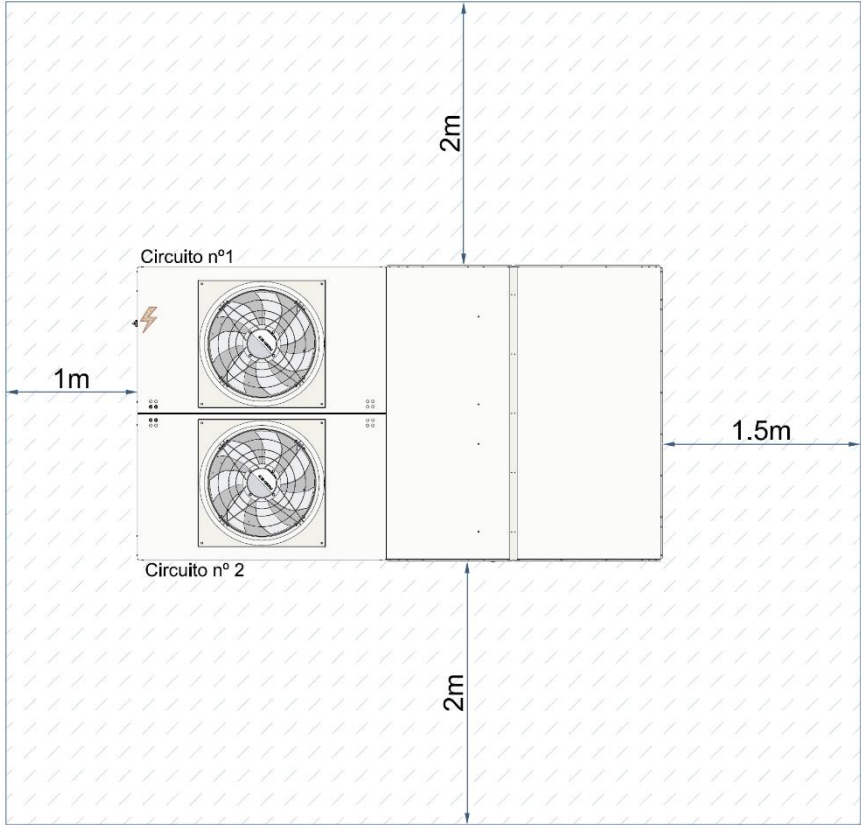

105 RCF model

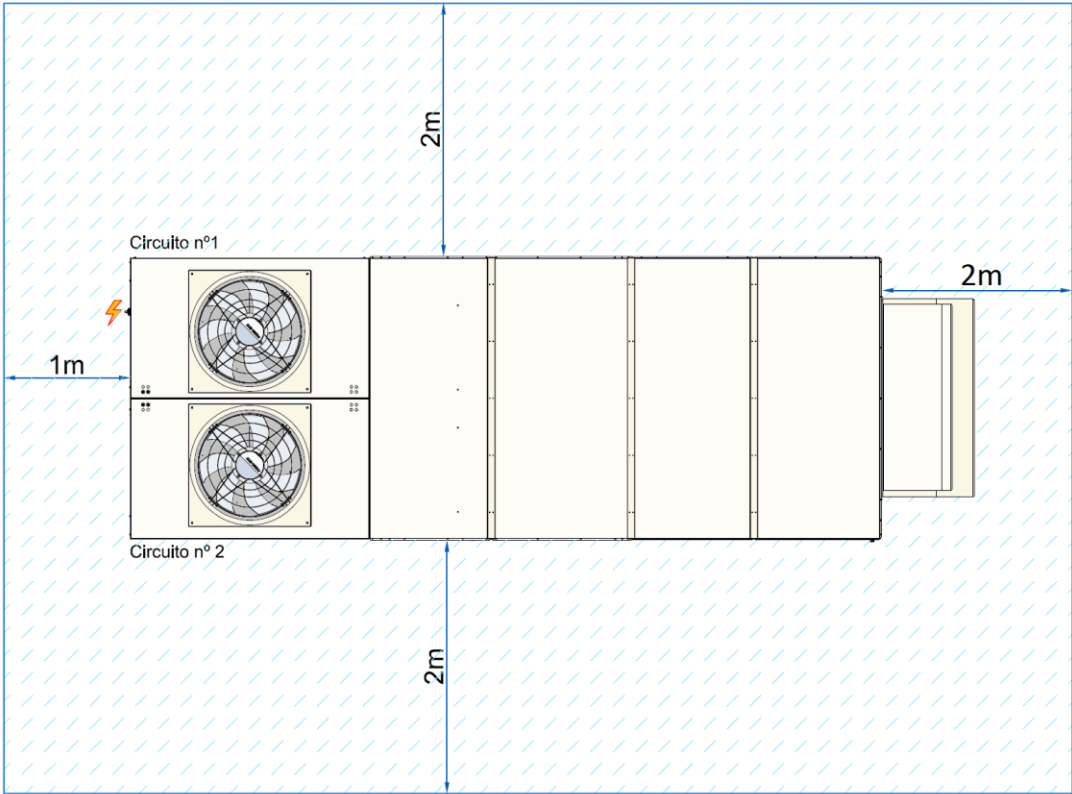

INSTALLATION - SERVICE AREA

125 to 210 models

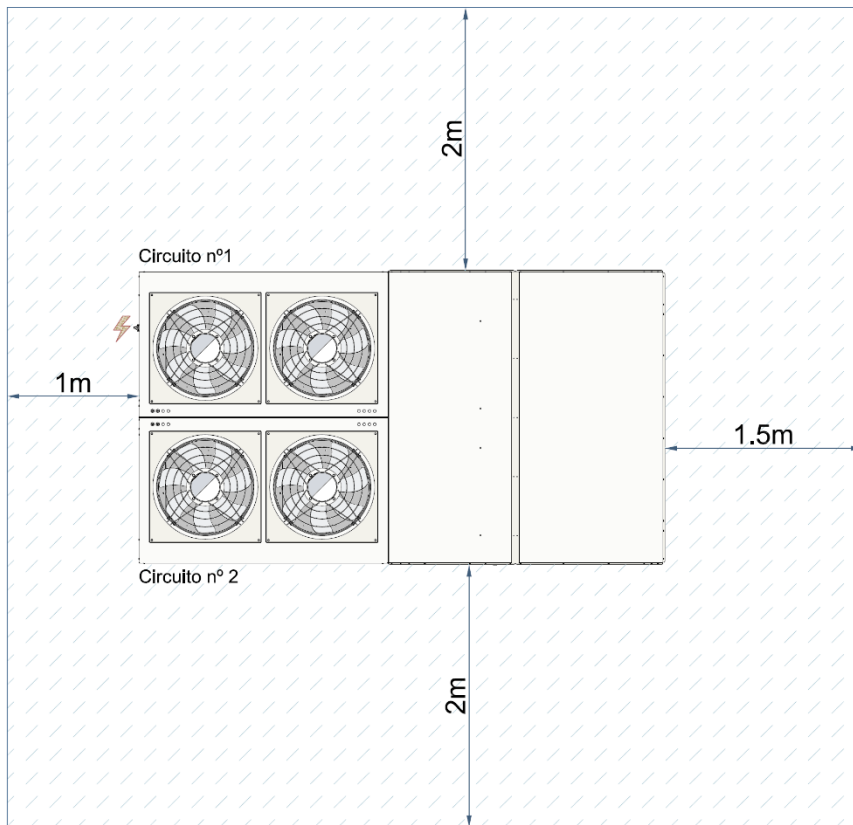

125 to 210 models with RCF

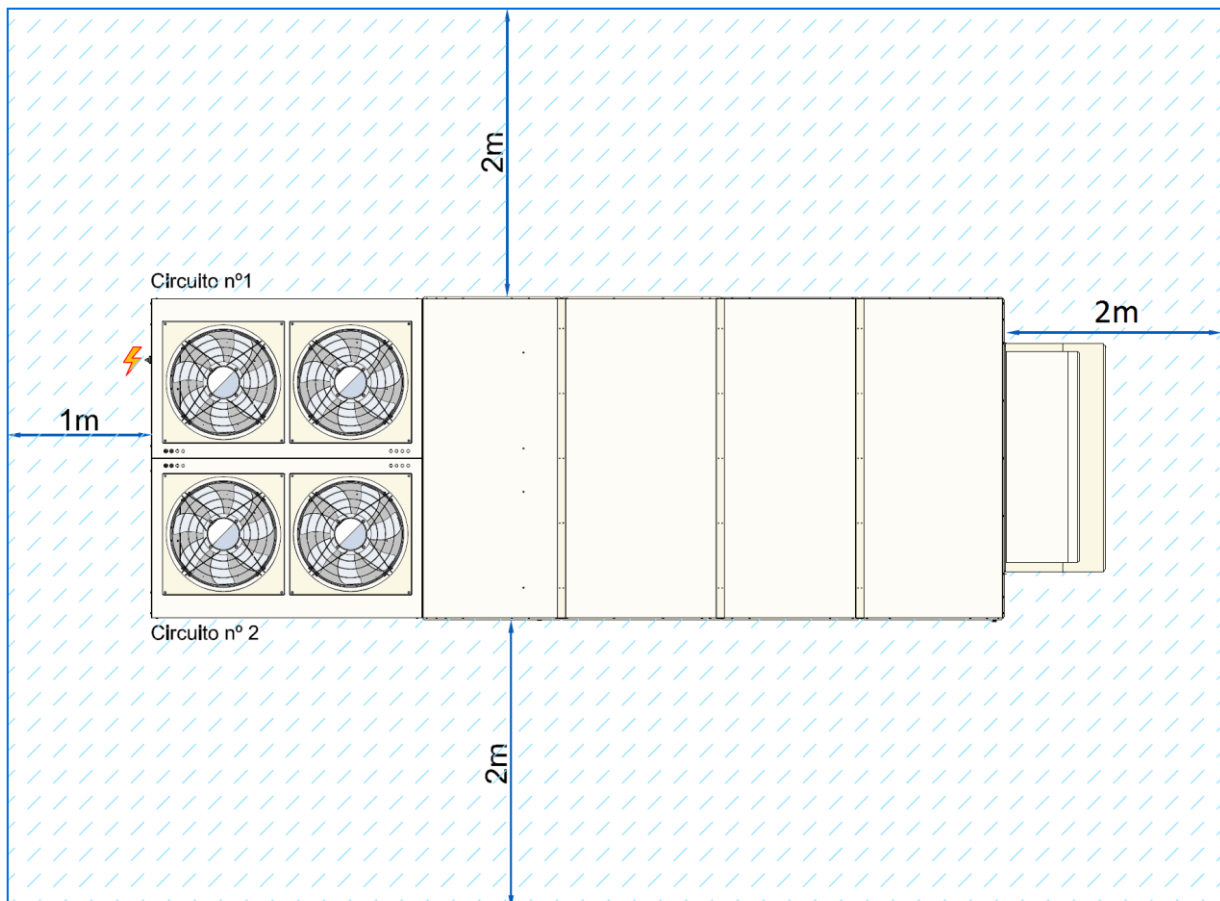

INSTALLATION

Assembly types – Standard Unit

Air supply configurations

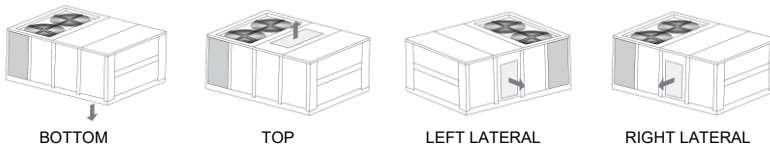

Return configurations

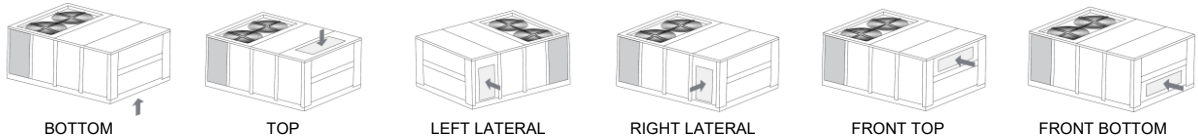

Free-cooling configurations

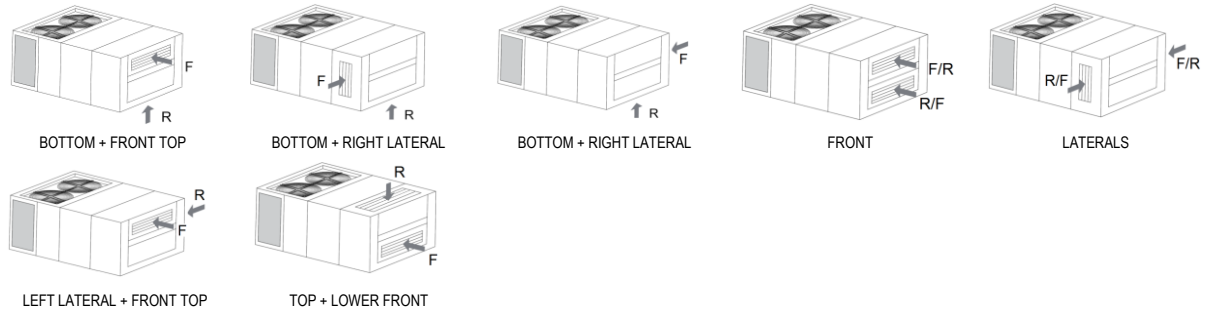

F: new air damper / R: return air damper
 *Consult the Technical Department for special configurations.

Examples of configurations

AIR SUPPLY / RETURN

Any combination of air supply and return is valid, taking into account that there can only be one air supply and one return.

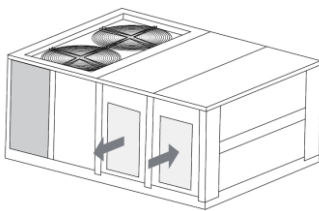

AIR SUPPLY / FREE COOLING

Any combination of air supply and return is valid, taking into account that there can only be one air supply and two dampers.

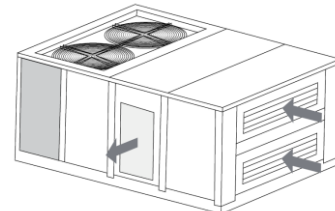

INSTALLATION

Assembly types for units with RCF module

Lateral return configurations

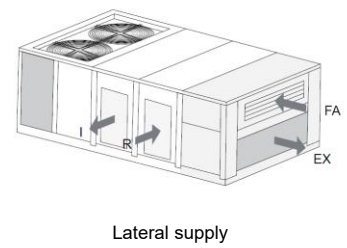
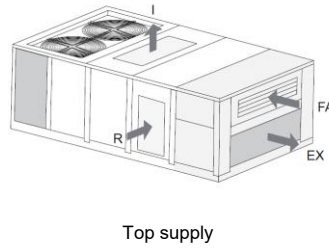
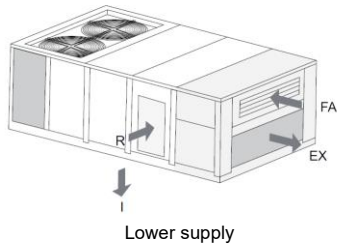

Lower return configurations

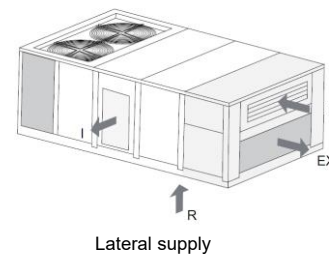
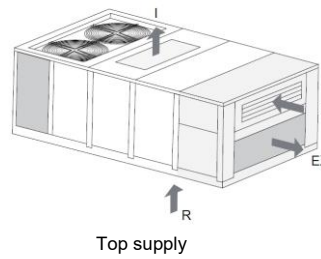
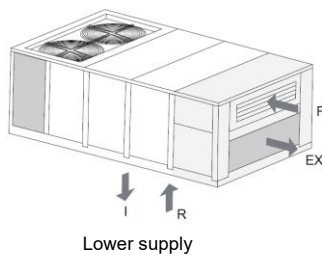

I: Supply / R: Return / FA: Fresh air / EX: Extraction air / I/D: Left and Right

INSTALLATION

ELECTRICAL INSTALLATION



WARNING!

Turn the main power switch off before starting any type of operation.

- Unit power supply should be within 10% of volts indicated on the unit nameplate. Damage caused by the start-up of the unit in an incorrect voltage line is not covered by Hitecsa's warranty.
- Always use the unit wiring diagram when making electrical connections.
- Be sure that the compressor crankcase heater can be energized before unit start.
- The line protection elements have to be placed by the installer according to the current legislation local laws.
- The interconnecting wires have to be in the protection tube or electrical cable conduits, cable trays, etc.
- The units can operate up to an altitude of 1000 m above sea level.

ELECTRICAL CONNECTIONS

Please refer to the user manuals and electrical diagrams for further information.
The electrical box may be opened to access the refrigerant components.

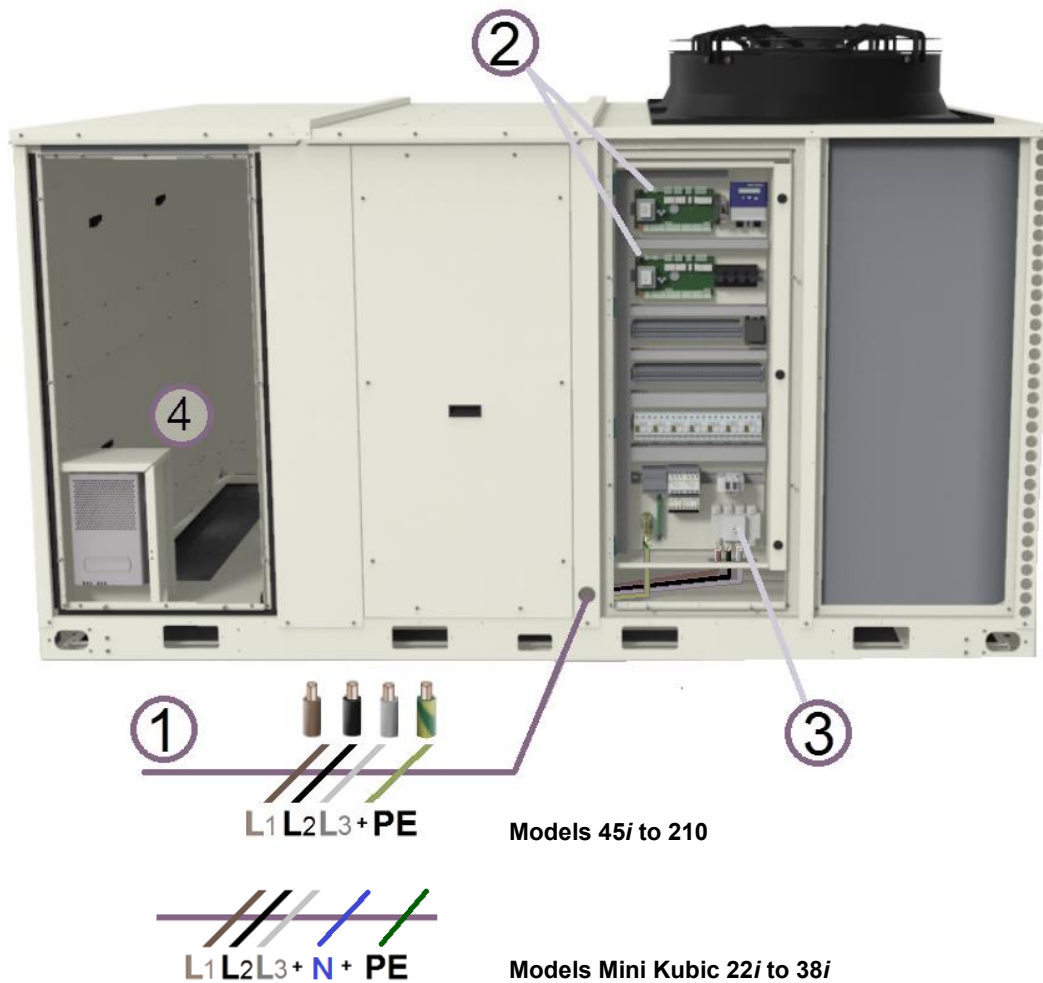

1. Power supply 400V, ~3, 50Hz + protection cable (45i to 210 models). Distribution type TN-S.
Power supply 400V / 3ph + N / 50Hz + protection cable (22i to 38i models). Distribution type TN-S.
2. Electronic boards (electrical box). For models from 22i to 38i there is only one plate.
3. Main switch of the unit (outer panel)
4. Only for inverter compressor units.

Thermostat: Please refer to the connection diagram.

INSTALLATION

ELECTRICAL INSTALLATION

Short-circuit current:

Models	Short-circuit current
Kubic 45 / 55 / 65 / 75 / 105 / 125 / 145 RCF 45 / 55 / 65 / 75 / 90	450A
Kubic 90 / 105 / 175 / 210 RCF 105 / 125 / 175	550A
RCF 210	800A
Kubic 125 / 210	1000A
Kubic 145	1100A

OPERATION



BEFORE START-UP

- Start-up has to be performed by a qualified service personnel in air conditioning.
- Make sure that the panels are firmly secured with screws.
- Check that there is no leakage of oil or refrigerant.
- Ensure that the unit is evenly levelled.
- Check if there is space enough for operation and maintenance.



Before opening the electrical panel and having access to the inside of the machine it is MANDATORY to disconnect the power supply cable of the machine which MUST BE FREE OF VOLTAGE for this operation.

- Check that the drainage is not blocked.
- Always use the electrical diagram of the unit to make the connections.
- Make sure that all electrical connections are properly tight.
- The power supply of the unit must comply with the data stated on the serial plate. Damage caused by the start-up of the unit with an incorrect voltage line will not be covered by Hitecsa's warranty.
- The unit must not be supplied with any other voltage than that indicated on the serial plate. The power supply to the unit must be within 10% of the voltage indicated on the serial plate.
- Check the correct rotation direction of the fans.
- The installer must place the line protection parts according to the current legislation.
- The electrical wires must be protected by a tube or other cable conduits.
- Make sure that the crankcase heater of each compressor has been operating for 24 hours prior the Start Up.
- Check that the air filters are clean and fitted correctly.
- Check the condition and position of the grilles, diffusers, air ducts, tarpaulins, etc.

START UP

- Register the air inlet and outlet temperatures to the internal coil, the volts and amperes of the compressor and motor fan, as well as the suction and discharge pressure of each compressor.
- Remember to clean the air filters after the first 4 hours of operation.
- Observe, at least, 3 cooling cycle operations.
- Since the unit is equipped with frequency converters it is essential that the protection is at least 300mA to prevent power cuts caused by the activation of the circuit breaker.

Indoor fan:



Attention, automatic restart!

The fan/motor may be switched on and off automatically due to functional reasons.

After a power failure or a main disconnection, an automatic restart of the fan takes place after voltage return!

Wait for the fan to come to a complete standstill before approaching it!

Rotation caused by an air flow in the wrong direction

When the fan is stopped (no signal, no electric supply, etc.), the control of the motor does not interfere if the fan rotates in the wrong direction (due to, for example, an air flow).

If you switch the fan on while it is rotating in the opposite direction, at first the control will reduce the rotations in a controlled way until it reaches the '0' value (fan stoppage). Then, the control will make a restart in the correct rotation direction.

The higher the number of rotations in the wrong direction, the longer time the controller will need to stop the fan.

If the fan is rotating strongly in the wrong direction, the controller may not be able to start the fan in the correct rotation direction.

INFORMATION!

Do not switch the line voltage off to make the fan start again!

The safe start of the fan is not guaranteed when it is rotating in the wrong direction. The installer or the user will need to take the necessary measures to prevent the fan from rotating in the wrong direction if a safe start is required.

MAINTENANCE



WARNING!



Before completing any service or maintenance operation, turn the main power switch off to avoid any personal injuries. Lock it so that nobody else than a qualified technician can switch it on.

Before opening the electrical panel and having access to the inside of the unit it is **MANDATORY** to disconnect the power supply hose of the machine which **MUST BE FREE OF VOLTAGE** for this operation.

- It is advisable to schedule maintenance visits every 1,000 operating hours, as well as at the end of summer. Please keep an updated record of all maintenance operations and readings (maintenance sheet).
- Any repairing operations or opening of the refrigerant circuit must be carried out by trained specialists only who are entitled legally by the official authorities.
- Wear safety shoes and gloves ADAPTED to each operation!
- Please observe the safety regulations and the worker's protection rules for any maintenance and service operation (EN 50 110, IEC 364).
- No maintenance work with running fans! BEWARE because fans can rotate without connection to power supply, e.g. when they are pushed by air currents.
- Use fire protection equipment for brazing operations (fireproof blankets) and
- In case of leakage, any manipulation and/or recovery of refrigerant shall be completed by qualified and authorized personnel in accordance with the valid regulation. Add the quantity of oil that has been lost.

CONSERVATION AND CLEANING

Precaution!

- Do not use aggressive cleaning products nor varnish solvents.
- Avoid water penetration inside the motor or the electronic components (e.g. through the direct contact with joints or holes of the motor), respect the protection class (IP).

Electrical circuit: Make sure that all electrical connections –wires, contactors and terminals- are tight. Register the readings of kW and amperes at each compressor and fan motor phase. Control the start-up current. Control that relays, power contactors, security devices and all switches work properly.

Refrigeration circuit: Check if there are any refrigerant leak, noises or vibration. Proceed to measuring temperatures and/or pressures of components of the most important components of the system and register them on the maintenance sheet (compressor discharge and aspiration, expansion valve, exchangers' inlet and outlet, etc...).

Compressor: Check regularly the lubricant level, the presence of vibrations or noise and the motor insulation.

Drainage system: Verify the condition and the correct operation of the drainage tray and tubes. It is necessary to clean the condensate trays after the first day of operation. Then, clean them at least once a year. Take into account the meteorological conditions, e.g. in areas where falling leaves or the flight of seeds may obstruct the drain trap, it will also be necessary to clean them at mid and late spring and autumn. The dates are approximate and will depend on the blooming, falling leaves, seeds seasons, etc. of the plants of the zone or the human activity or any other cause. Check the access to the condensate trays if fitted.

Filtros de aire: Clean the filters after the first operation hours to remove possible light materials such as pieces of paper or polystyrene, etc. that may have been dragged by the air circulation. Clean again every 3 months (or more often depending on operation). The filters can be cleaned with soapy water. Then rinse them with clean water and let dry. If necessary replace the filters before they are in poor condition (refer to the current legislation, EN 779, UNE-EN 13053...).

Coils: At least once a year clean the condenser coils with water and detergent, then dry with air at low pressure. Never clean with a wire brush, water and/or air at high pressure (max. 6 bar).



MAINTENANCE

Fans: Control that device regularly. Frequency of inspection will depend on the level of dirt that will be observed on the propellers, the turbine, etc. Check the direction of rotation of the fans, verify their carriers. Check the transmission elements and the operation status.

Before maintenance operations make sure that it is disconnected from the main power supply even though it is already stopped and control that nobody may start it during the intervention.

- A regular inspection of the unit is required to avoid dirt accumulation in propellers, turbines, motors and grids that could entail risks and significantly shorten their life. The frequency will depend on the working conditions.
- Keep the airways of the fan free – danger of expulsion of objects!
- Check the free flow of the condensation water through the evacuation openings is necessary (if there are any).
- During cleaning operations, be very careful not to unbalance the propeller or the turbine.
- In case of incorrect cleaning operations, no guarantee is assumed regarding corrosion formation / paint adhesion for unpainted / painted fans.
- To avoid humidity accumulation in the motor the fan must be operated during at least 1 hour at 80 to 100% of its maximum speed before cleaning!
- After the cleaning process, the fan must be operated for 2 hours at 80 to 100% of maximum speed for drying purposes!
- Check the fan regularly to detect possible mechanical vibrations (recommended every 6 months). Take into consideration the limit values stated in the ISO 14694 standard and take the necessary correction measures in case of exceeding them (e.g. posterior balance by trained specialists).
- Check the impeller in particular weld-seams to detect possible cracks.
- The motors and the fans do not require additional lubrication due to the use of “life-long lubrication” ball bearings. At the end of the grease life period (30-40.000h approx.), the bearing shall be replaced. Please contact our Service Department in that case as well as for any damage (e.g. to the coil or electrical parts).

LUBRICATION

Each compressor manufacturer use a specific oil for their products. Refer to the technical specifications of the unit to see what type of oil is used.

As a general rule, synthetic ester-type lubricants (POE, Polyol Ester) or PVE (polyvinyl ether) oil with a high solubility level with refrigerant are used. These types of oil are very hygroscopic and shall be handled with more care than the conventional oils. Moreover, when these synthetic oils are mixed with minerals (MO) or alkylbenzenes (AB), they deteriorate causing capillary blockage or failure in the compressor.

DO NOT MIX THEM UNDER ANY CIRCUMSTANCES.

The compressor or system should not remain open to atmosphere for more than 15 minutes as the oil might be contaminated by the air humidity and it would be necessary to proceed to vacuuming during a long time to eliminate that humidity.

REPAIRING OPERATIONS

- For all maintenance and repairing operations the current safety rules of each country have to be checked and followed.
- It is forbidden to do brazing repairing operations on mechanic elements such as fans, compressors, valves, etc.
- Use only spare parts/ wear parts / original accessories from the manufacturer of the fans. These parts have been designed especially for the unit. If you use parts from other manufacturers it is not guaranteed that they have been manufactured to resist loads that they will have to support or that they meet the relevant safety requirements.
- The parts and any special equipment that have not been supplied by the manufacturer of the fans are not authorized by these manufacturers and cannot be used for the equipment.
- **Fan with EC motor:** For safety reasons it is forbidden to realize on your own any modification on the device. Any planned modification shall be accepted previously by written by the manufacturer.

SPECIAL INSTRUCTIONS FOR R32 REFRIGERANT



WARNING!

Never use oxygen to pressurize the system or purge lines for leak test. Oxygen reacts violently with oil, which may entail an explosion that could lead to damages, personal injury or event death.

MAINTENANCE

Controls:

- Before any operation, use a special detector of inflammable refrigerants to inspect the area.
- Please make sure that the clearing distances around the unit are respected according to the "SERVICE AREA" section of the present manual.
- Verify that marking on the equipment is visible and legible. If it is not so, proceed to rectifying.
- Make sure that no component that may contain refrigerant is or might be exposed to substances that could corrode them unless they have previously been properly prepared for corrosion exposure.
- Make sure that no electrical components are connected and that the condensers have been previously discharged.

Volume and surface area:

Please follow carefully the legal requirements regarding cooling and heating installations paying special attention to the required conditions and minimum space depending on the charge of R32 refrigerant of the unit (or the size of the longest circuit if the unit comprises more than one) due to its toxicity and flammability characteristics. Take into consideration the classification of the site according to the access conditions as well as the precise location of the unit.

Fire extinguisher:

Make sure to always have at hand a dry powder or a CO₂ extinguisher close to the working site.

Sources of ignition

Keep any type of possible ignition source: tobacco, lighter, welding torch, etc.. away from the installation site. Fix no smoking warning plates close to the installation.

Recovery and evacuation of refrigerant

For any operation that implies the opening of the refrigerant circuit, some improvements to the conventional proceedings shall be added due to the flammability of the R32 refrigerant:

- Extract the refrigerant with a special recovery device and proceed to vacuuming thereafter.
- Proceed to bleeding the circuit with an inert gas by filling it up to approx. 8 bars (dry nitrogen without oxygen).
- Proceed to evacuating and vacuuming.
- Proceed to bleeding again with inert gas.
- Open the circuit (by cutting or brazing).
- Make sure that there is no ignition source when extracting and vacuuming.

When recovering refrigerant from the circuit, please make sure that the electronic expansion valves (EEV) are fully open so that the complete emptying of the circuit is guaranteed without any risk that some of the refrigerant circuit may remain isolated.

Thus the installer/maintenance staff shall use a special tool that enables to keep the EEV open while the emptying process is carried on:

- Either by mean of a control module which enables the opening of the EEV electronically (pGD thermostat).
- Or by mean of special magnets that will keep the EEV open mechanically.

An incomplete emptying of the refrigerant circuit before it shall be refilled with refrigerant will entail a possible risk of critical damage of the unit which would invalidate the warranty.

Repairing leaks

Proceed to repairing leaks immediately, do not wait until the unit has no charge.

Use authorised leak detectors for flammable refrigerants and specially calibrated for R32. Should you use detection fluids, verify that they do not contain chlorine. If the unit is installed in a closed room, provide a good ventilation with outdoor air.

For leaks that require brazing, first of all proceed to recovering the entire circuit refrigerant charge until the atmospheric pressure level (so as not to absorb air due to the leak). Afterwards proceed to bleeding the leakage zone with dry nitrogen that does not contain oxygen. Repeat that operation and control that the area around the unit is properly ventilated and with no refrigerant trace. After controlling that there is no refrigerant in the air, proceed to brazing. During brazing, keep nitrogen (depressurised) circulating in the tubes. Verify that the leakage zone has been repaired correctly by charging nitrogen. Finally proceed to vacuuming and charging.

Refrigerant charging

It is compulsory to use an electronic scale that is specially prepared to support the refrigerant bottle handling. Introduce the refrigerant through the charging valves in the inlet zone. Use a pressure gauge to measure the pressure of the unit. The charging hoses shall not contain air and shall be equally filled up with gas before and after charging.

Open or prick the charging valve to start the process. Should you wish to accelerate this operation or if it has stopped before completion, turn the unit on bearing in mind that pressure shall be between 4 and 8 bars. If pressure is higher than 8 bars, close the bottle before turning the unit on. When pressure decreases open the bottle until pressure has reached the previous mentioned values.

NEVER WARM THE BOTTLE UP TO ACCELERATE THE CHARGING PROCESS.

The R32 refrigerant is a pure gas that maintains its properties when it is charged in the liquid or the vapour phase. It is not necessary to empty the circuit completely when the exact charge that has been removed is known. In case of any doubt, proceed to emptying the circuit completely and charge again according to the weight that is stated on the name plate of the unit.

MAINTENANCE

FAN WITH EC MOTOR

The use of capacitors implies a danger of death even after switching the device off in case of direct contact with conductive parts or with parts that carry voltage due to fault conditions. Removing or opening the housing of the controller and the terminal box for example is only permitted after the power supply cable has been disconnected for 3 minutes.

Trouble shooting

Type of error	Possible cause	Solution
Fan does not run (anymore)	Failure line voltage. Failure of one phase. Under – or overvoltage.	Check line voltage.
	Earth fault.	Check motor connection and line voltage.
	Short circuit winding.	Replace fan.
	The thermal protection of the motor has triggered (motor is overheated)	Check for free air passages; remove foreign bodies if necessary "Impeller blocked or dirty". Check temperature of supply air. Check voltage.
	Impeller blocked or dirty	<ul style="list-style-type: none"> • Switch off power to the motor and secure against switching back on. • Check safe isolation from supply. • Remove safety grille. • Remove foreign bodies or soiling. • Remount the safety grille.
Fan will not start	Temperature too low for bearing grease.	Insert bearing with cold greasing.
	Air stream wrong direction (Motor turns in wrong direction at high speed)	Check air stream. ☞ Behaviour in rotation by air current in reverse direction.
Fan turns too slowly	Impeller / blade scrapes / brushes.	When indicated clear foreign bodies / dirt from the fan.
	Active temperature management effective (Motor or electronics overheated).	Check for free air passages; remove foreign bodies if necessary. "Impeller blocked or dirty". Check temperature of supply air. Check installation space (air speed overheat sink).
Air flow too low	Fan turns too slowly	☞ "Fan turns too slowly".
	Airways blocked	Check for free air passages (supply/exhaust air vents, filters) "Impeller blocked or dirty"
	Pressure loss different to planned.	Check fan selection.
Vibrations	Imbalance.	Check blades for damage, soiling or ice. "Impeller blocked or dirty"
	No or wrong vibration dampers (only in radial)	Install correct vibration dampers
Unusual noises	Bearing damaged / worn.	Change bearings.
	Impeller / blade scrapes / brushes.	When indicated clear foreign bodies / dirt from the fan. "Impeller blocked or dirty"
	Operation beyond stall point (for axial fans)	Check for free air passages (supply / exhaust air vents, filters)
	Wrong overlap on nozzle (for centrifugal fans)	Observe the installation instructions.

MAINTENANCE

FANS WITH EC MOTOR

Status Out with flash code



For motor size "D" and "G" status LED integrated in cover.



LED Code	Alarm relay *	Cause (Explanation)
OFF	Open	No line voltage
ON	Closed	Normal operation without fault
1x	Closed	Not enable = OFF
2x	Closed	Active temperature management
3x	Open	HALL-IC fault
4x	Open	Line failure (only for 3~ types)
5x	Open	Motor blocked
6x	Open	IGBT fault
7x	Open	DC under voltage
8x	Open	DC overvoltage
9x	Closed	IGBT cooling down period
11x	Open	Fault motor start
12x	Open	Line voltage too low
13x	Open	Line voltage too high
14x	Open	Error peak current
17x	Open	Temperature alarm

* Alarm relay: function programmed by manufacturer: error message not reversed.
 The alarm "Critical alarm thermostats interlock security" appears in pGD of Mini pGD.

OPTIONS

KUBIC NEXT	22i	26i	32i	38i	45i	55i	65i	75i	90i	105	125	145	175	210
400 V/Three-phase/50 Hz WITHOUT neutral	●	●	●	●	●	●	●	●	●	●	●	●	●	●
Rubber-metal anti-vibration shock-absorbers	○	○	○	○	○	○	○	○	○	○	○	○	○	○
Indoor radial fan with EC motor	●	●	●	●	●	●	●	●	●	●	●	●	●	●
Indoor radial fan with EC motor, Available High Pressure	X	X	○	○	○	○	○	○	○	○	○	○	○	○
Axial outdoor fans with EC motors	●	●	●	●	●	●	●	●	●	●	●	●	●	●
Variable speed axial fans	○	○	○	○	○	○	○	○	○	○	○	○	○	○
Electronic expansion valve, indoor exchanger	●	●	●	●	●	●	●	●	●	●	●	●	●	●
Electronic expansion valve, outdoor exchanger	●	●	●	●	●	●	●	●	●	●	●	●	●	●
Pressure transducers	●	●	●	●	●	●	●	●	●	●	●	●	●	●
High acoustic insulation jacket for compressor	○	○	○	○	○	○	○	○	○	○	○	○	○	○
PGD thermostat	○	○	○	○	○	○	○	○	○	○	○	○	○	○
Mini-PGD thermostat (outside the box)	○	○	○	○	○	○	○	○	○	○	○	○	○	○
ModBus board	○	○	○	○	○	○	○	○	○	○	○	○	○	○
BACNet IP / ModBus IP communication	○	○	○	○	○	○	○	○	○	○	○	○	○	○
Zoning control (Temperature and air quality control in 2 different zones) through the pGD/mini pGD	Please contact BAXI				●	●	●	●	●	●	●	●	●	●
Supply air temperature probe	●	●	●	●	●	●	●	●	●	●	●	●	●	●
Outdoor temperature probe	●	●	●	●	●	●	●	●	●	●	●	●	●	●
Refrigerant discharge temperature probes	●	●	●	●	●	●	●	●	●	●	●	●	●	●
Th-Tune thermostat	●	●	●	●	●	●	●	●	●	●	●	●	●	●
Temperature probe included in the Th-Tune thermostat	●	●	●	●	●	●	●	●	●	●	●	●	●	●
Indoor ambient air temperature probe	○	○	○	○	○	○	○	○	○	○	○	○	○	○
Temperature probe for duct	○	○	○	○	○	○	○	○	○	○	○	○	○	○
Ambient air temperature and humidity probe	○	○	○	○	○	○	○	○	○	○	○	○	○	○
Air temperature and humidity probe for duct	○	○	○	○	○	○	○	○	○	○	○	○	○	○
VOC Quality probe	○	○	○	○	○	○	○	○	○	○	○	○	○	○
CO ₂ Quality probe	○	○	○	○	○	○	○	○	○	○	○	○	○	○
Ambient smoke detector	○	○	○	○	○	○	○	○	○	○	○	○	○	○
Smoke detector for ducts	○	○	○	○	○	○	○	○	○	○	○	○	○	○
Thermal, enthalpy or thermal-enthalpy Free Cooling	○	○	○	○	○	○	○	○	○	○	○	○	○	○
Heat recovery module	○	○	○	○	○	○	○	○	○	○	○	○	○	○
G4 class thick filter	●	●	●	●	●	●	●	●	●	●	●	●	●	●
M6 class medium filter	○	○	○	○	○	○	○	○	○	○	○	○	○	○
F7, F8, F9 class thin filter	○	○	○	○	○	○	○	○	○	○	○	○	○	○
Air differential Pressure switch (Detection of clogged filter)	○	○	○	○	○	○	○	○	○	○	○	○	○	○
Double stage filtration	○	○	○	○	○	○	○	○	○	○	○	○	○	○
Triple stage filtration	○	○	○	○	○	○	○	○	○	○	○	○	○	○
Air differential Pressure switch (Double stage filtration)	○	○	○	○	○	○	○	○	○	○	○	○	○	○
Air differential Pressure switch (Triple stage filtration)	○	○	○	○	○	○	○	○	○	○	○	○	○	○
10 mm thermo-acoustic insulation	●	●	●	●	●	●	●	●	●	●	●	●	●	●
A1 (M0) fire-proof insulation for Thermal Sandwich Panel	Please contact BAXI				○	○	○	○	○	X	X	X	X	X
Indoor and outdoor coils with level 3 protection treatment	○	○	○	○	○	○	○	○	○	○	○	○	○	○
Indoor and outdoor coils with level 5 protection treatment	○	○	○	○	○	○	○	○	○	○	○	○	○	○
Indoor and outdoor coils with level 6 protection treatment	○	○	○	○	○	○	○	○	○	○	○	○	○	○
Condensate tray for outdoor coil	○	○	○	○	○	○	○	○	○	○	○	○	○	○
Protection for outdoor coils	○	○	○	○	○	○	○	○	○	○	○	○	○	○
Soft start - compressors	●	●	●	●	○	○	○	○	○	○	○	○	○	○
Detection of refrigerant leakage	○	○	○	○	○	○	○	○	○	○	○	○	●	●
Hot water coil (1 row; 60-40°C or 80-60°C)	Please contact BAXI				○	○	○	○	○	○	○	○	○	○
Hot water coil (2 rows; 60-40°C or 80-60°C)	Please contact BAXI				○	○	○	○	○	○	○	○	○	○
With RCF/VRR/Free cooling, mixture air temperature probe	Please contact BAXI				●	●	●	●	●	●	●	●	●	●
With RCF/VRR/Free cooling, mixture air temperature and humidity probe	Please contact BAXI				○	○	○	○	○	○	○	○	○	○

● Standard ○ Option x Not available

OUTDOOR FANS WITH PKDM / PKDT

Led of internal state, diagnosis through flash codes.

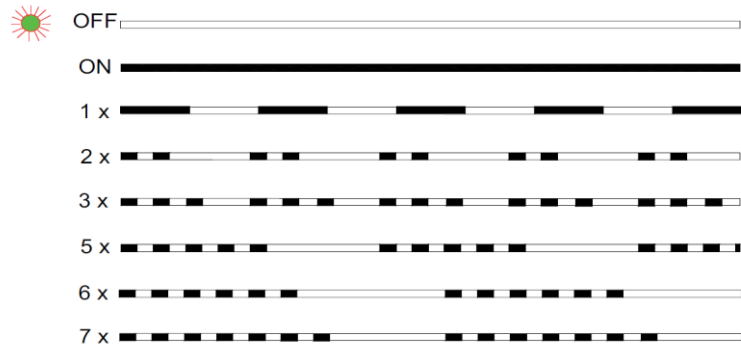

LED code	Relay K1	Explanation	Reaction of the controller Omission of the error
OFF	Does not receive voltage Terminals 11-12 bypassed	No voltage on the network	When the voltage of the network is missed, the unit is disconnected "OFF" and, once the voltage of the network is intact again, goes back to connect to "ON". Check the network and the internal fuse of the unit.
ON	Open Terminals 11-14 bypassed	Normal service without errors	
1	Open Terminals 11-14 bypassed	None exemption Terminals "D1"- "D1" (Digital in 1) not bypassed	Disconnection through external contact (digital input) The unit disconnects and connects again.
2	Does not receive voltage Terminals 11-12 bypassed	Motor failure Trip of a thermo-switch / temperature sensor or interruption between both terminals "TB".	Checking of the motor and connection and, then, reset (protection of the motor)
3	Does not receive voltage Terminals 11-12 bypassed	Overcharge Power semi-conductor (heat sink) too hot.	Disconnection at 95 °C, reconnection after cooling at 65 °C. Check if the unit is overcharged i.e. if the max regulation current produced is over the nominal current of the unit. Temperature control on the unit, cooling control of the unit.

MAINTENANCE

OUTDOOR FANS WITH PKDM

LED code	Relay K1	Explanation	Reaction of the controller
			Solution
4	Open Terminals 11-14 bypassed	Heat sink sensor Interrupted the cable to the sensor on the heat sink.	The supervision of the power semiconductor temperature is not active already! Check the cable of the sensor and substitute the unit if it is not possible any solution!
5	Does not receive voltage Terminals 11-12 bypassed	Network error Failure of a network phase or instable supply of the network.	The unit disconnects (OFF) and connects (ON) again automatically when the mains supply is intact Check the network and the internal fuse of the unit (every time it is available)
6	Open Terminals 11-14 bypassed	Signal failure Code 6 for input "E1" Code 7 for input "E2"	Depending on the short-circuit or the interruption and on the type of programmed operation, the unit works with the min or max modulation. Once the cause of the error has been removed, the unit works automatically again with the mean value on the sensor.
7		Function only available in the service as a controller (from 2.01)!	Check sensor
		In case of interruption or short circuit of the sensor line, or measure values out of the range of measure: - PT 1000 below -25 °C approx. and over 75 °C approx. in temperature sensor TF (KTY) type. - In active sensors when the minimum or maximum signal values are reached (depending on the signal type selected).	

DETECTION OF REFRIGERANT LEAKS (OPTION FOR 22i TO 145 MODELS, STANDARD FOR 175 AND 210 MODELS)

The leak detector is supplied separately and shall be mounted during installation in the air supply duct. Please refer to the following drawing for details about the position of the probe.

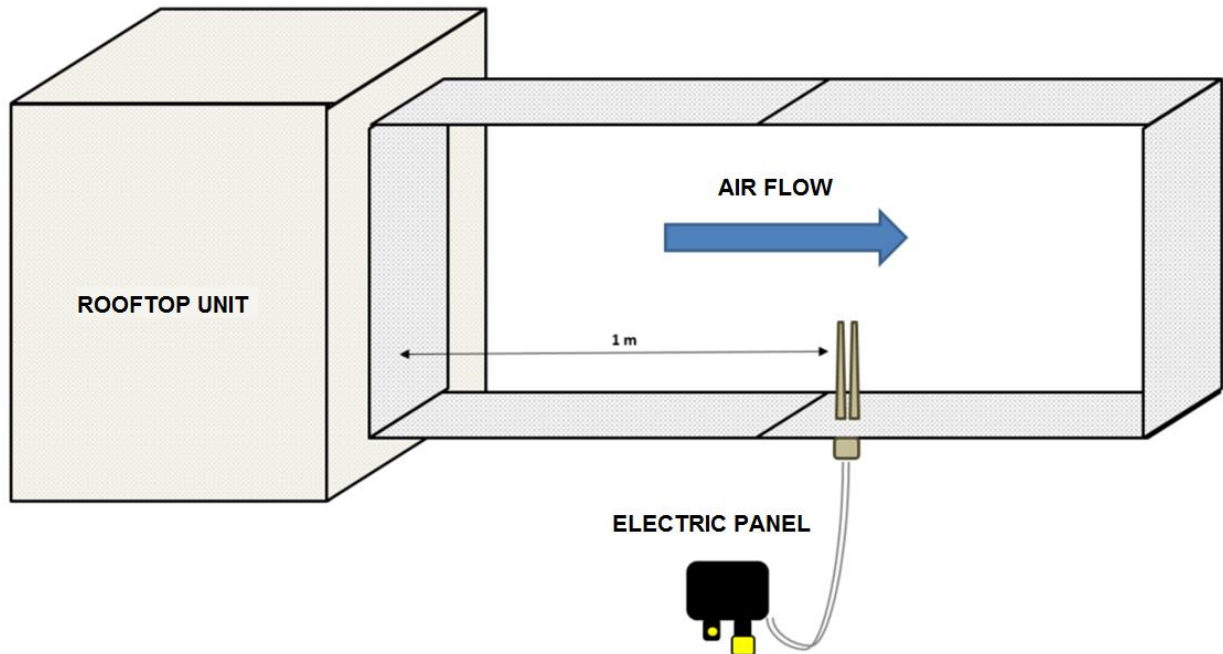

TH-TUNE or pGD/Mini pGD (option) CONTROLLERS

Please refer to the separate controller manual.

BAXI CLIMATIZACIÓN, S.L.U.
C. López de Hoyos, 35, Planta Baja
28002 Madrid
España

Tel. +34 902 89 80 00
www.baxi.es
informacion@baxi.es



CE



007

BAXI

Translation of the original instructions.
Subject to modifications without previous notice

