

SERVICE MANUAL

AIRCONDITIONER

EUROPE MARKET

SUPER DC INVERTER MULTI TYPE



DC MULTI OUTDOOR UNITS

CONTENTS

1. General information of Outdoor Units	2
2. Features	3
3. Dimensions.....	4
4. Refrigeration Cycle Diagram	5
5. Wiring diagram	9
6. Indoor units combination	26
7. Sound Levels.....	33
8. Installation Details	34
8.1 Wrench torque sheet for installation	34
8.2 Connecting the cables	34
8.3 Pipe length and the elevation	34
8.4 Installation for the first time.....	37
8.5 Adding the refrigerant after running the system for many years	40
8.6 Re-installation while the indoor unit need to be repaired	41
8.7 Re-installation while the outdoor unit need to be repaired.....	43
9. Electronic control function.....	45
10. Troubleshooting	60



Caution: Risk of fire/flammable materials

1. General information of Outdoor Units

Model name	Dimension (mm)	Compressor
M2OG-14HFN8-Q	800x333x554	KSN140D21UFZ
M2OC-18HFN8-Q	800x333x554	KSM135D23UFZ
M2OD-18HFN8-Q	800x333x554	KSN140D21UFZ
M3OF-21HFN8-Q	845x363x702	KSN140D21UFZ
M4OA-24HFN8-Q	890x342x673	KTM240D46UKT2
M3OE-27HFN8-Q	845x363x702	KTF235D22UMT
M3OF-27HFN8-Q	845x363x702	KTM240D57UMT
M4OB-36HFN8-Q	946x410x810	KTF310D43UMT
M4OE-28HFN8-Q	946x410x810	KTM240D57UMT
M5OD-42HFN8-Q	946x410x810	KTF310D43UMT
M5OE-42HFN8-Q	946x410x810	KTF310D43UMT
M2OH-14HFN8-Q	805x330x554	KSN140D58UFZ
M2OE-18HFN8-Q	805x330x554	KSN140D58UFZ
M3OG-21HFN8-Q	890x342x673	KSN140D58UFZ
M3OA-27HFN8-Q	890x342x673	KTM240D57UMT
M3OB-27HFN8-Q	890x342x673	KTM240D57UMT
M3OD-27HFN8-Q	890x342x673	KTM240D46UKT2
M4OC-36HFN8-Q	946x410x810	KTF310D43UMT
M3OA-18HFN8-Q	805x330x554	KSN140D58UFZ
M2OF-18HFN8-Q	890x342x673	KSN140D58UFZ
M3OC-27HFN8-Q	946x410x810	KTM180D68UMT
M4OD-36HFN8-Q	946x410x810	KTM310D86UMTA
M5OG-42HFN8-Q	946x410x810	KTM310D86UMTA

2. Features

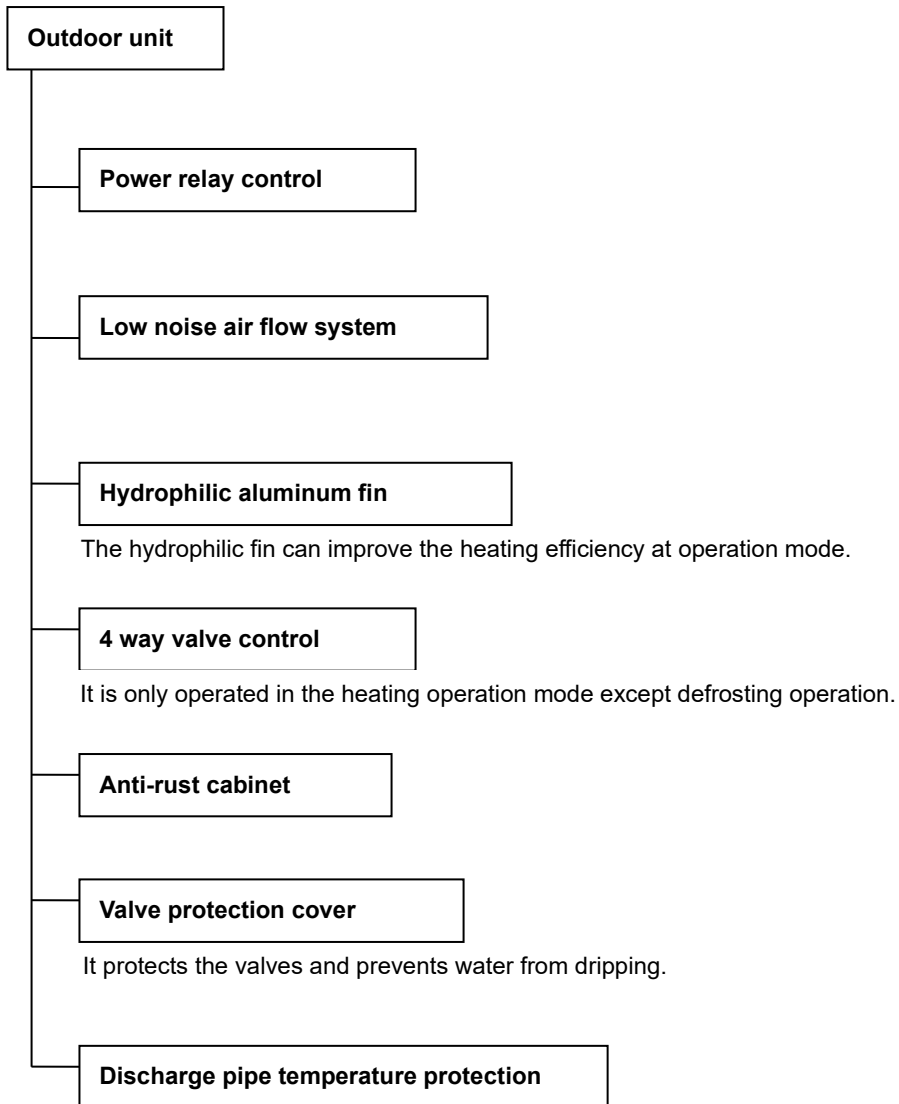

3. Dimensions

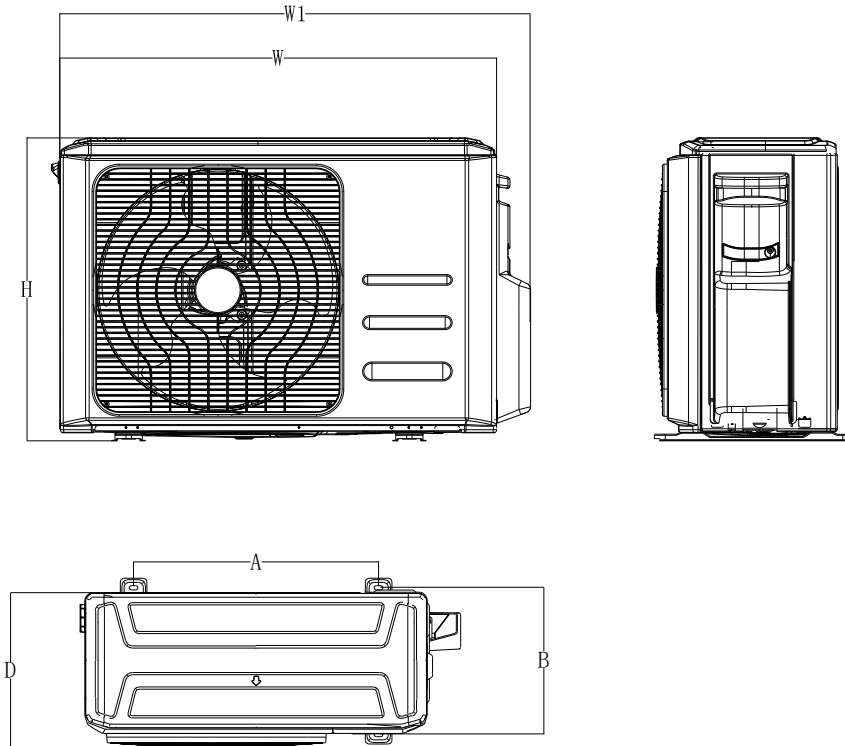

Model	Unit: mm					
	W	D	H	W1	A	B
M2OG-14HFN8-Q	800	333	554	860	514	340
M2OC-18HFN8-Q	800	333	554	860	514	340
M2OD-18HFN8-Q	800	333	554	860	514	340
M3OF-21HFN8-Q	845	363	702	923	540	350
M3OE-27HFN8-Q	845	363	702	923	540	350
M3OF-27HFN8-Q	845	363	702	923	540	350
M4OE-28HFN8-Q	946	410	810	1034	673	403
M4OB-36HFN8-Q	946	410	810	1034	673	403
M5OD-42HFN8-Q	946	410	810	1034	673	403
M5OE-42HFN8-Q	946	410	810	1034	673	403
M2OH-14HFN8-Q	805	330	554	877	511	317
M2OE-18HFN8-Q	805	330	554	877	511	317
M3OA-18HFN8-Q	805	330	554	877	511	317
M3OG-21HFN8-Q	890	342	673	990	663	354
M3OA-27HFN8-Q	890	342	673	990	663	354
M3OB-27HFN8-Q	890	342	673	990	663	354
M3OD-27HFN8-Q	890	342	673	990	663	354
M2OF-18HFN8-Q	890	342	673	990	663	354
M4OA-24HFN8-Q	890	342	673	990	663	354
M3OC-27HFN8-Q	946	410	810	1034	673	403
M4OC-36HFN8-Q	946	410	810	1034	673	403
M4OD-36HFN8-Q	946	410	810	1034	673	403
M5OG-42HFN8-Q	946	410	810	1034	673	403

4. Refrigeration Cycle Diagram

4.1 Refrigeration circuit drawing of inverter 1 drive 2 type

M2OC-18HFN8-Q, M2OG-14HFN8-Q, M2OD-18HFN8-Q

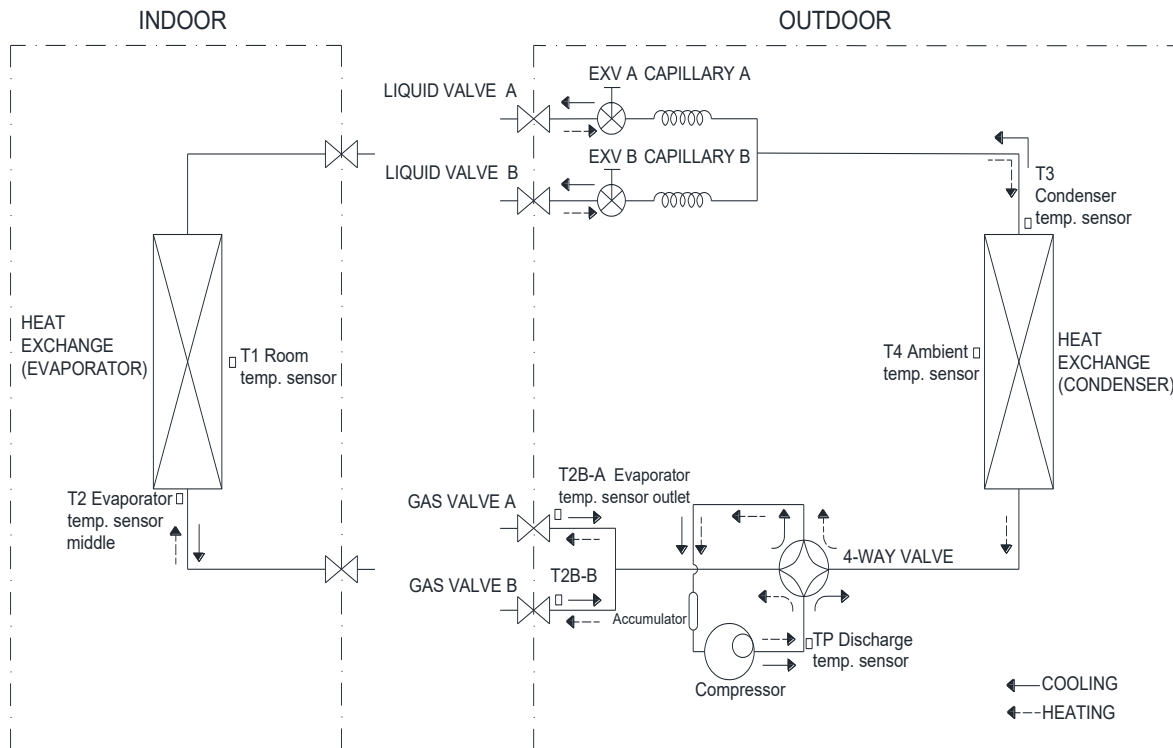

M2OH-14HFN8-Q, M2OE-18HFN8-Q, M2OF-18HFN8-Q

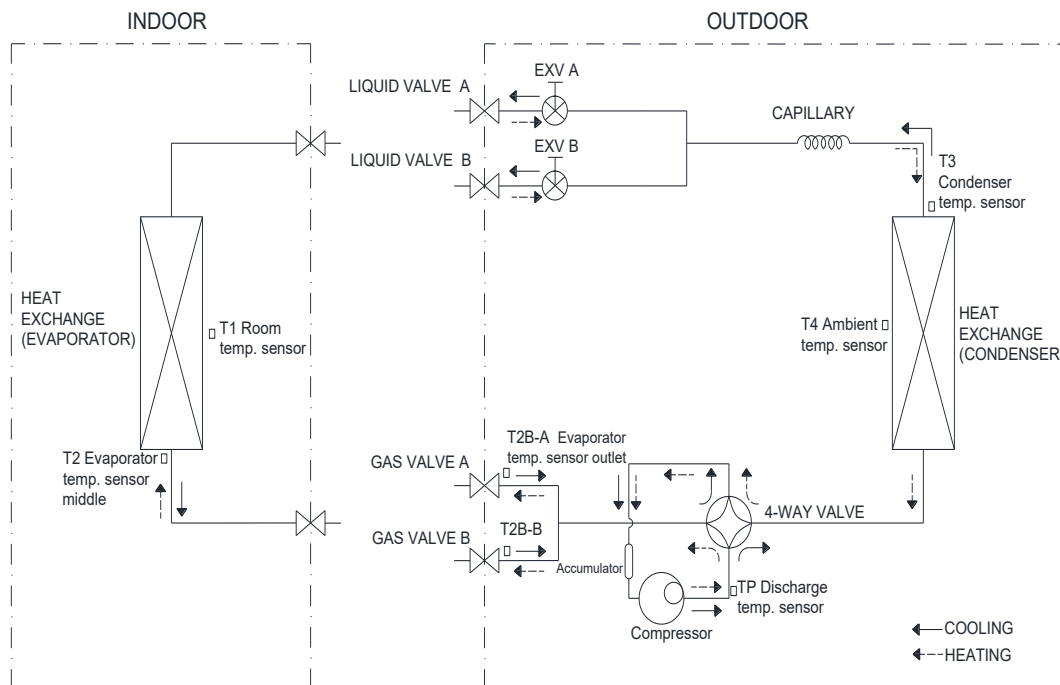

4.2 Refrigeration circuit drawing of inverter 1 drive 3 type

M3OB-27HFN8-Q, M3OC-27HFN8-Q

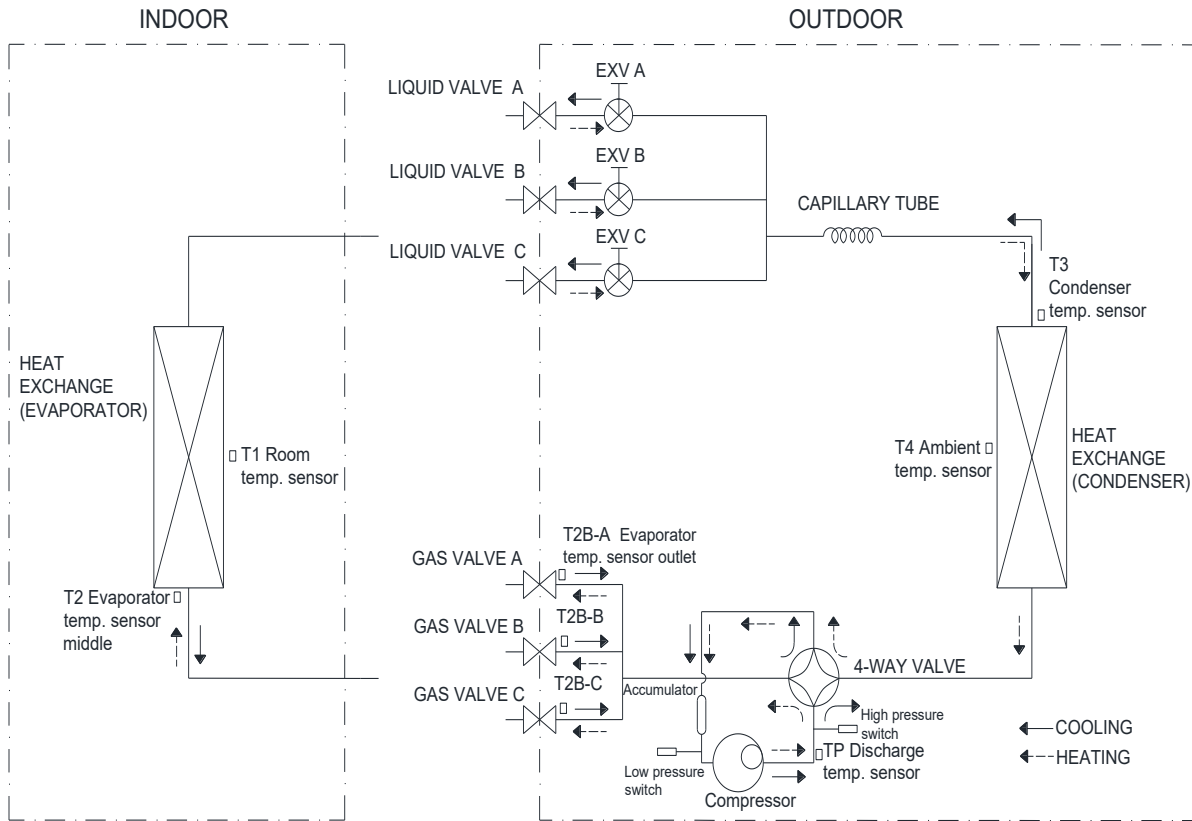

M3OF-21HFN8-Q, M3OE-27HFN8-Q, M3OF-27HFN8-Q, M3OA-18HFN8-Q, M3OG-21HFN8-Q

M3OA-27HFN8-Q, M3OD-27HFN8-Q

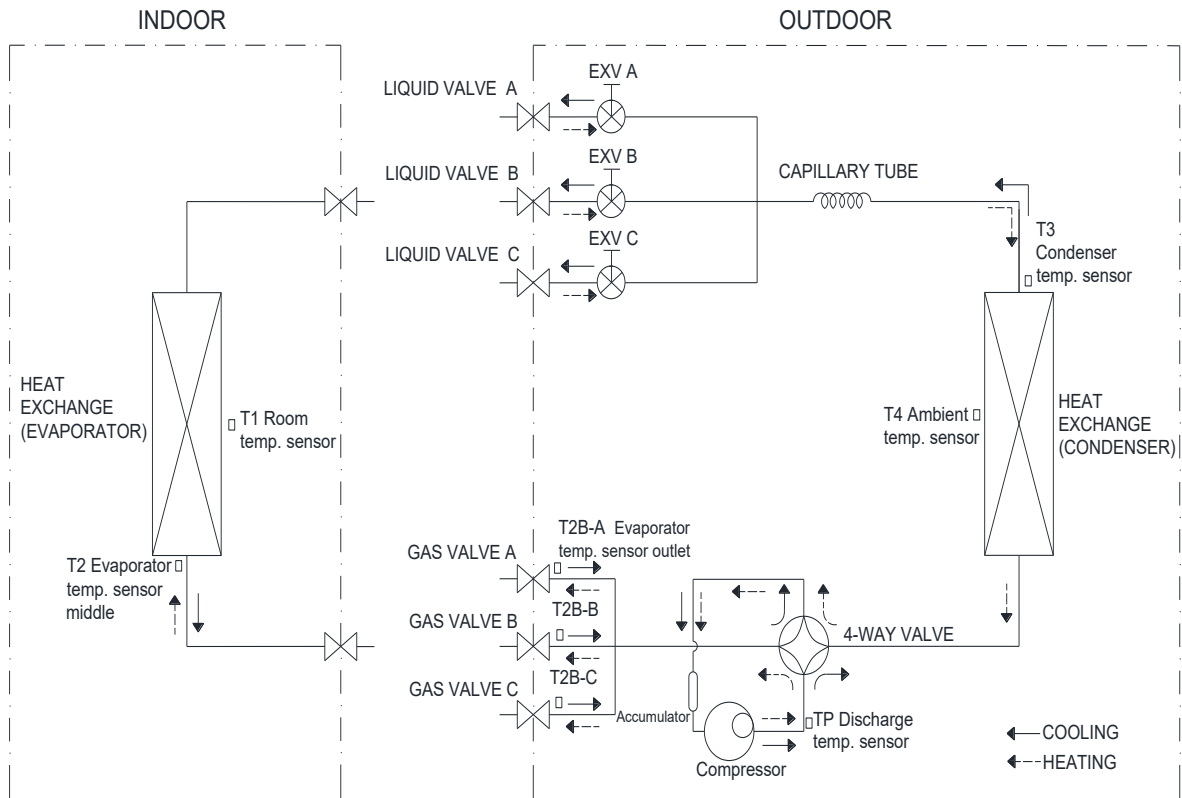

4.3 Refrigeration circuit drawing of inverter 1 drive 4 type

M4OA-24HFN8-Q

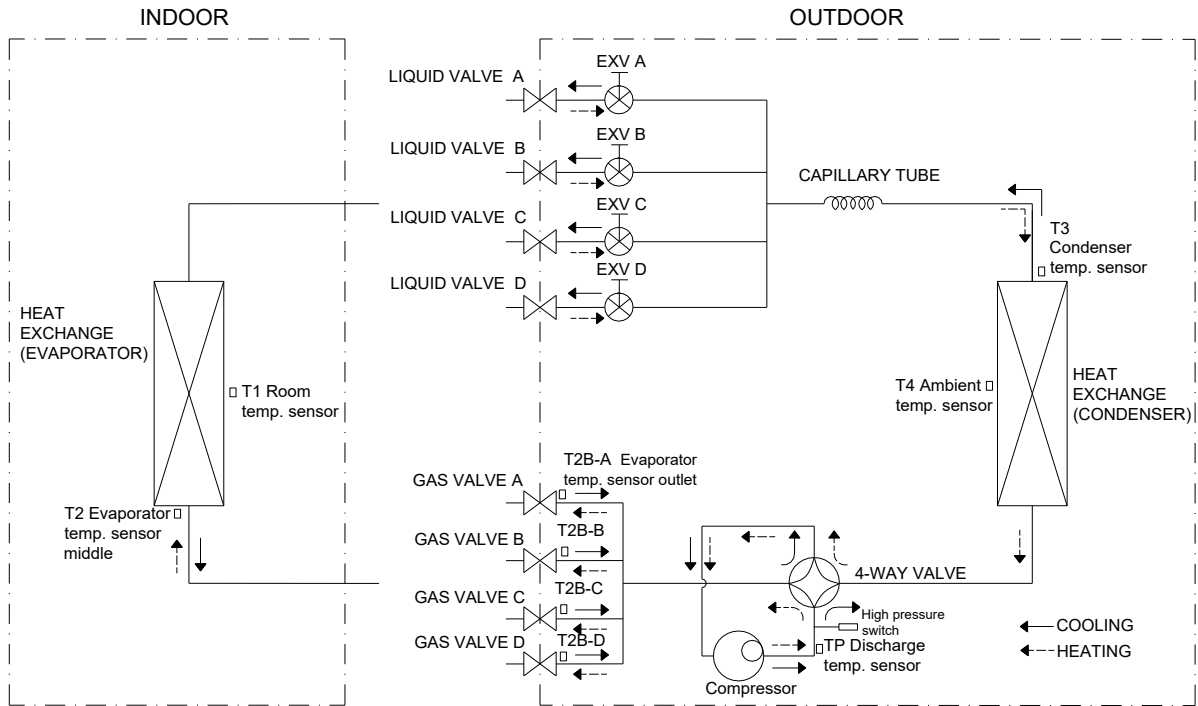

M4OE-28HFN8-Q, M4OB-36HFN8-Q, M4OC-36HFN8-Q, M4OD-36HFN8-Q, 22022316002946

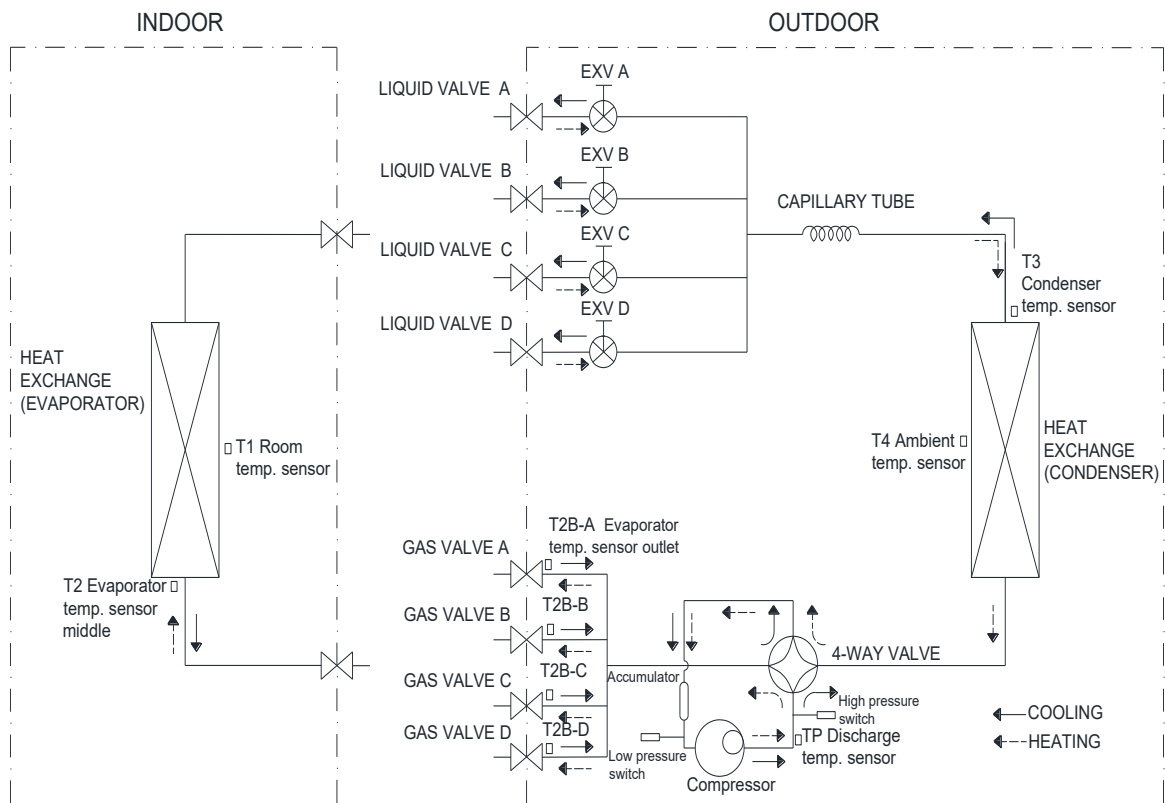

4.4 Refrigeration circuit drawing of inverter 1 drive 5 type

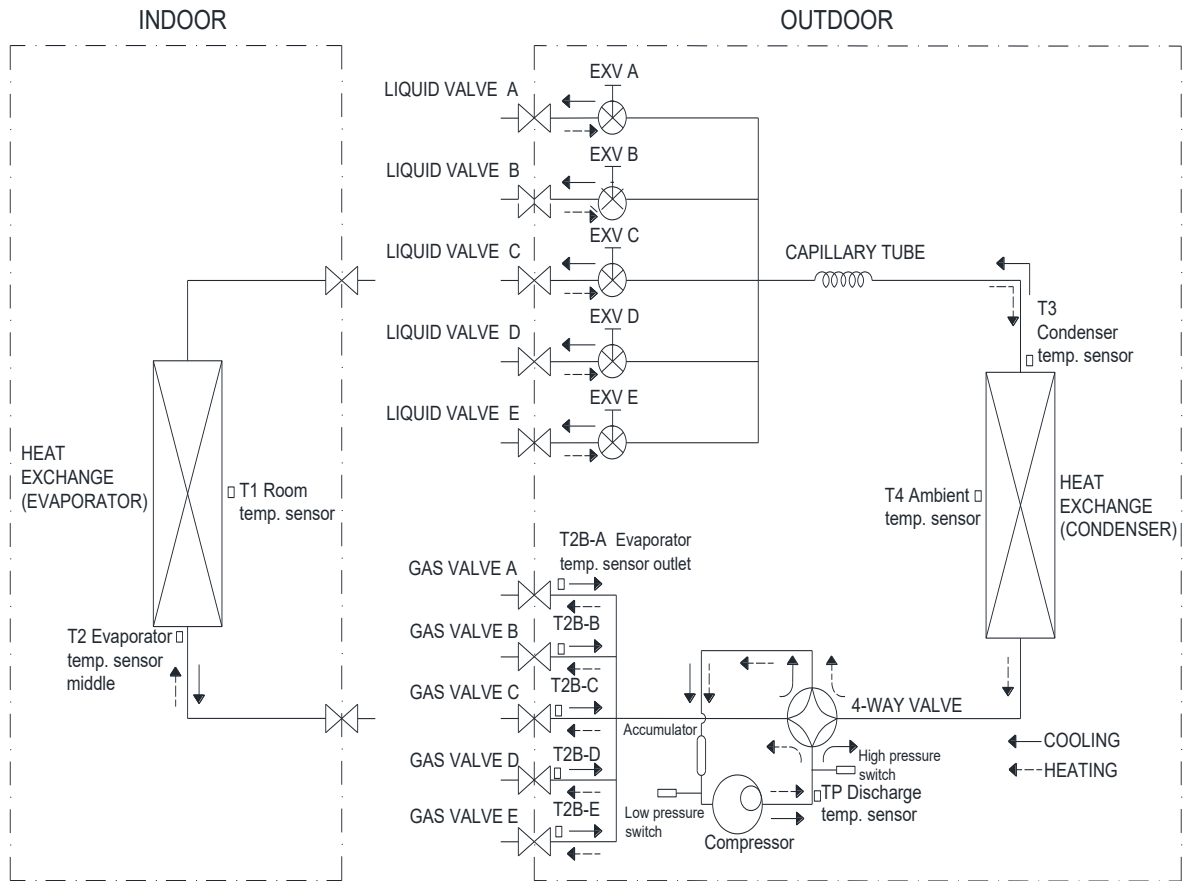

5. Wiring diagram

M2OC-18HFN8-Q

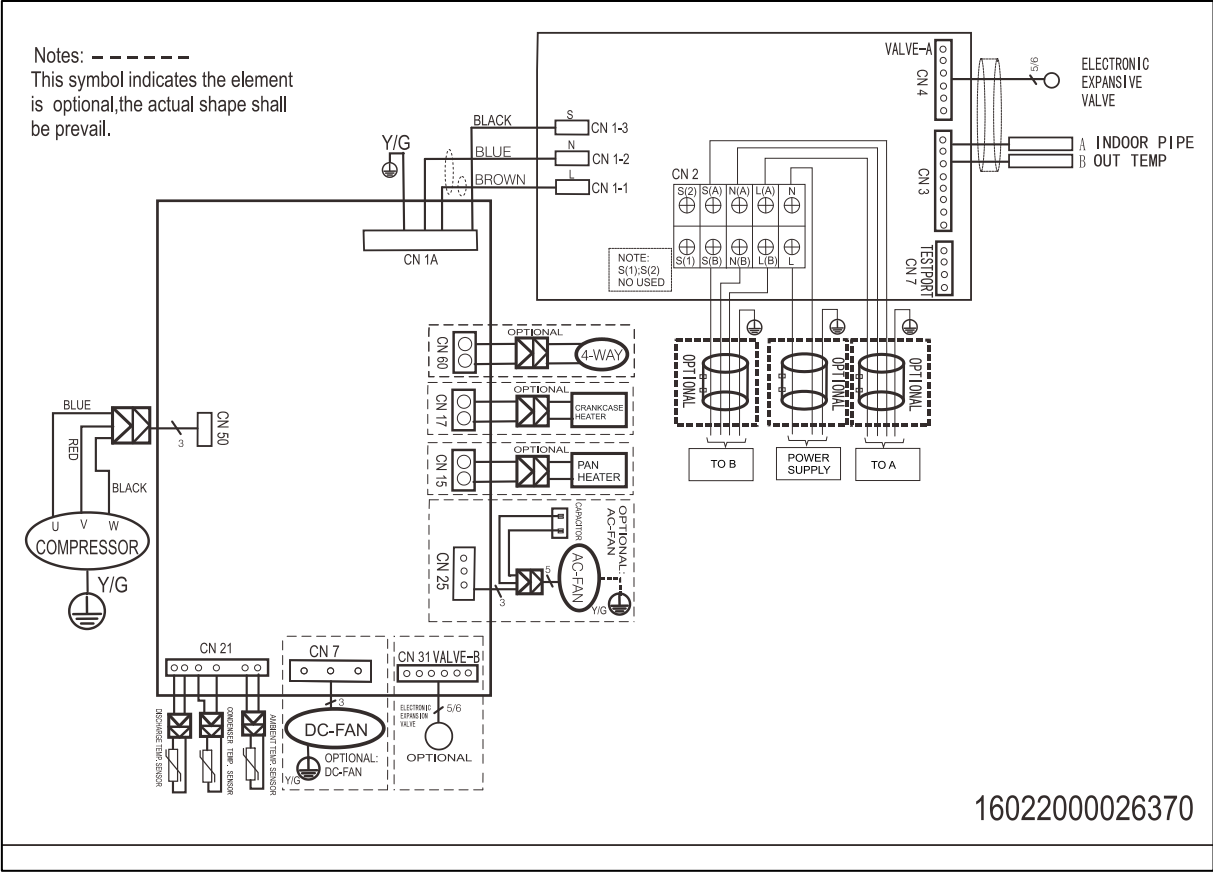

M2OD-18HFN8-Q

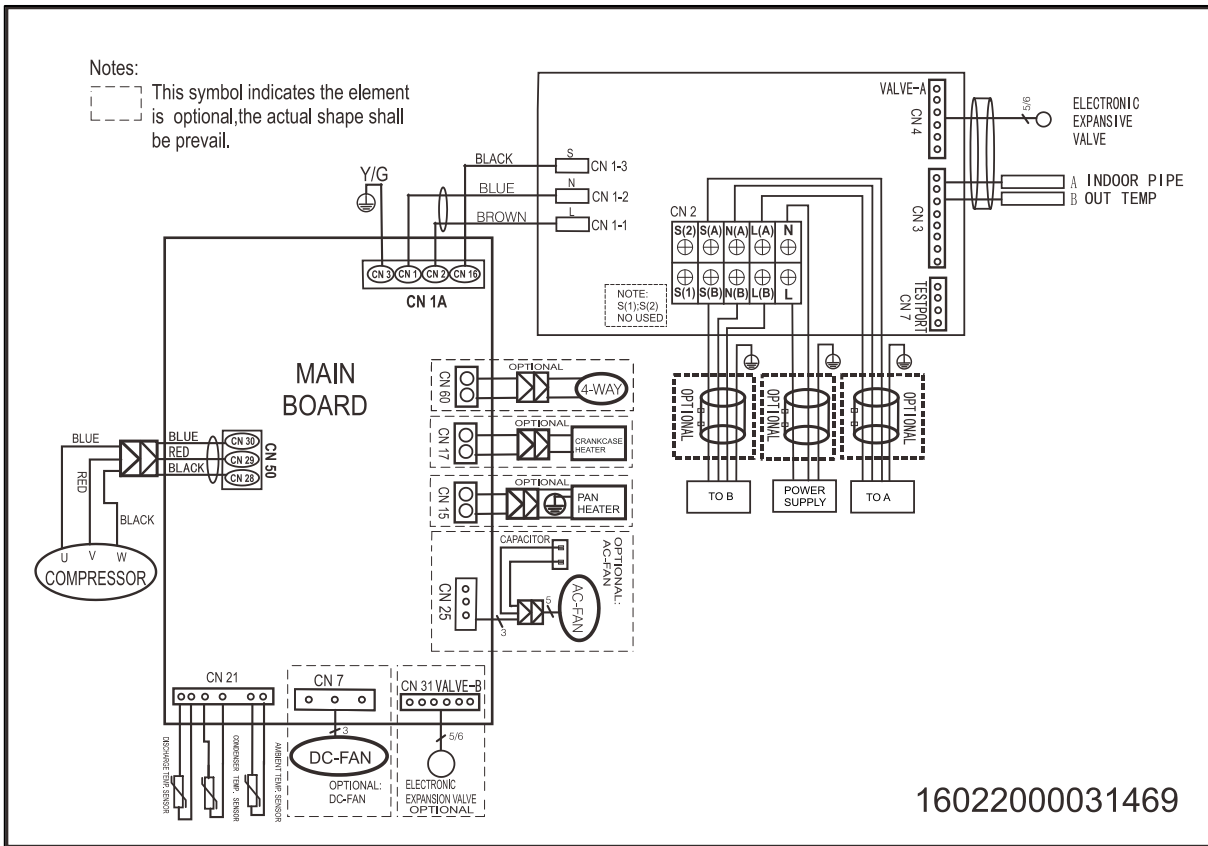

M2OG-14HFN8-Q, M2OH-14HFN8-Q, M2OE-18HFN8-Q

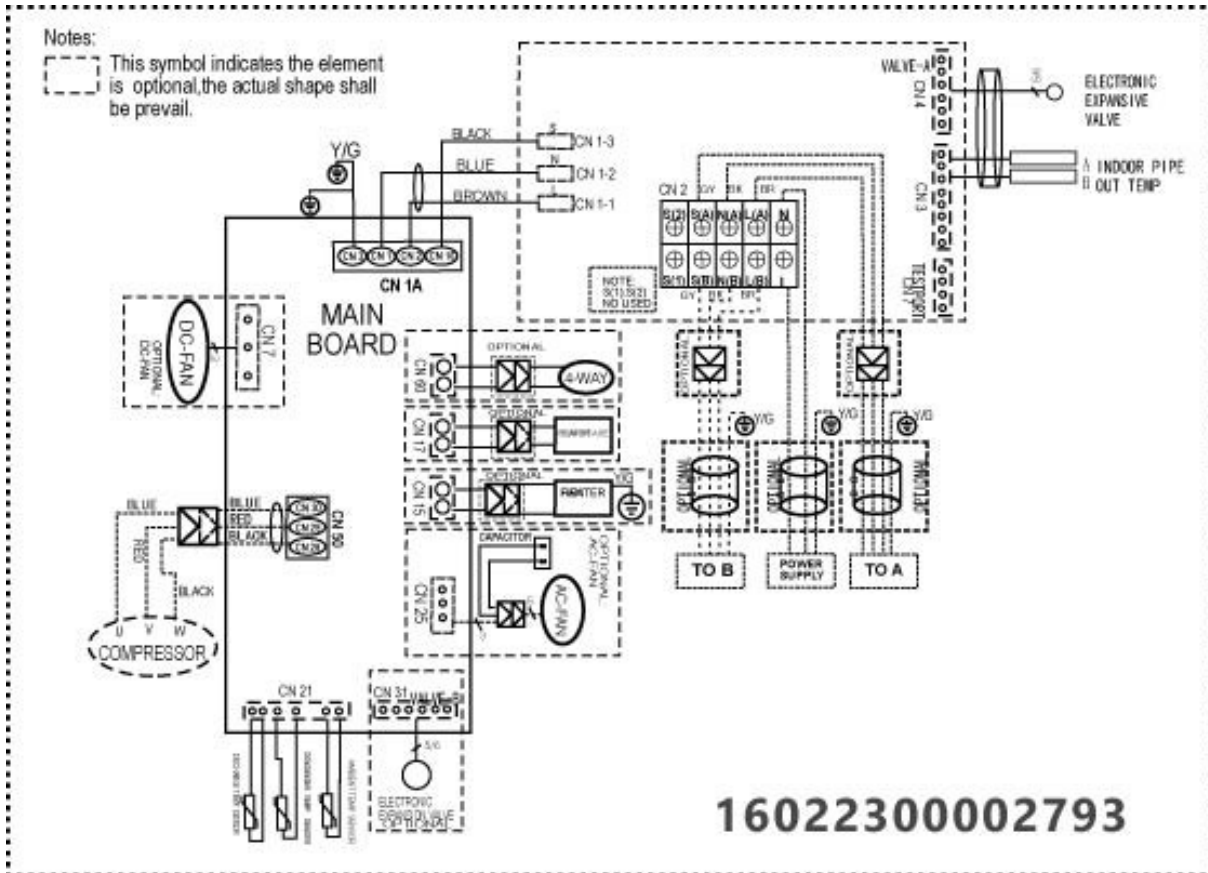

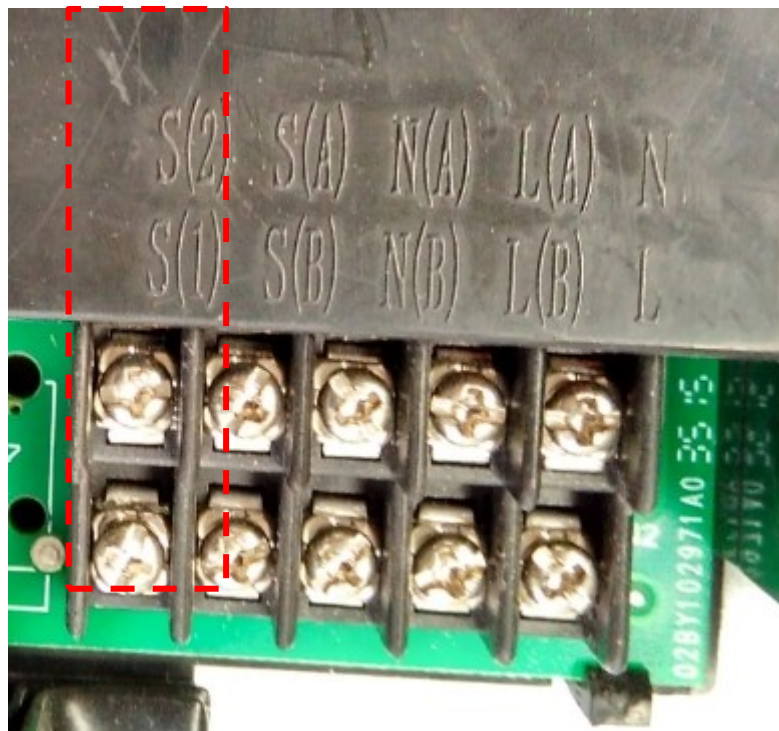
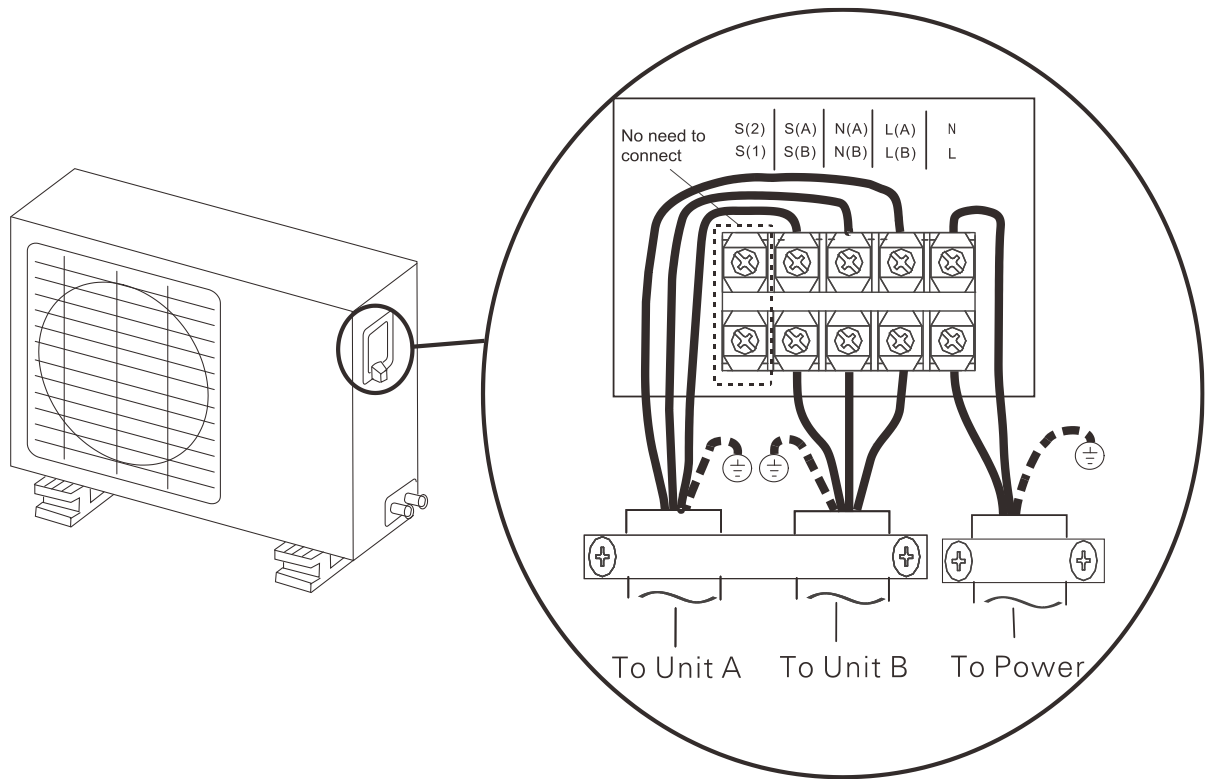



Note: S(1)&S(2) are used in other type of models. They don't need to be connected in multi models.

M2OF-18HFN8-Q

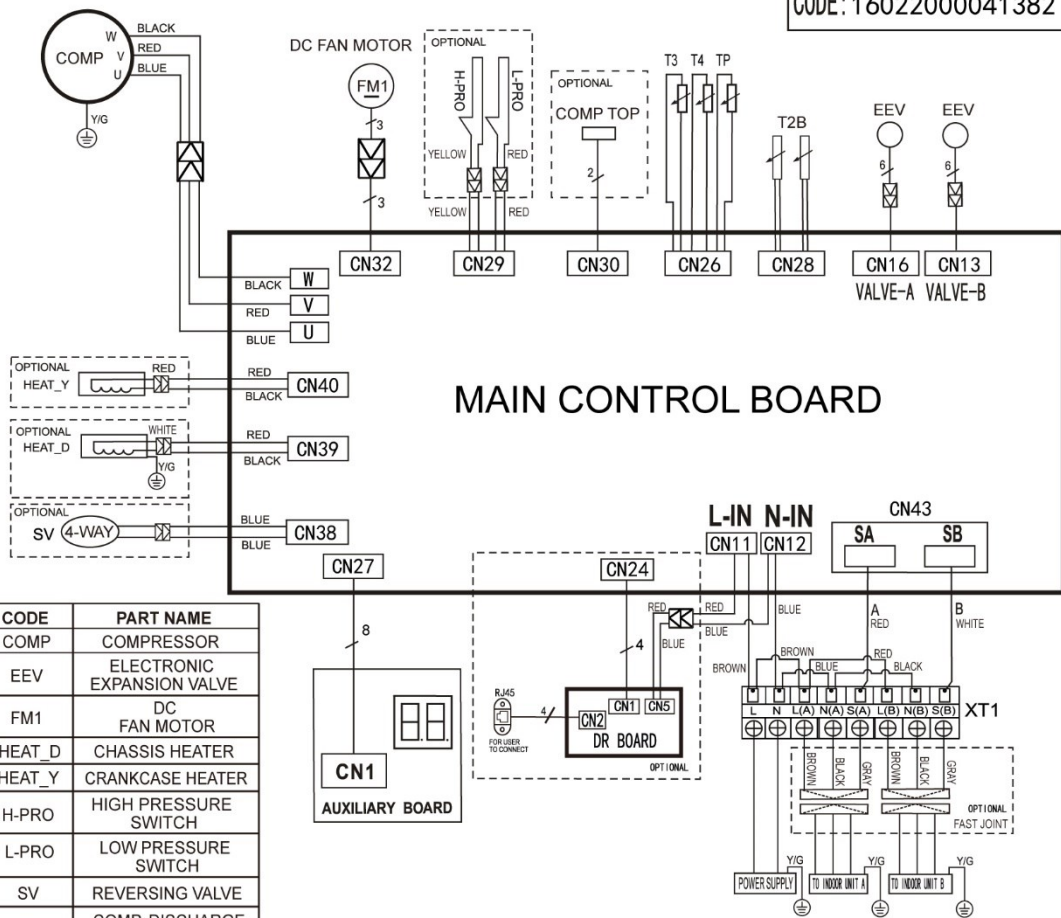
CODE: 16022000041382



CODE	PART NAME
COMP	COMPRESSOR
EEV	ELECTRONIC EXPANSION VALVE
FM1	DC FAN MOTOR
HEAT_D	CHASSIS HEATER
HEAT_Y	CRANKCASE HEATER
H-PRO	HIGH PRESSURE SWITCH
L-PRO	LOW PRESSURE SWITCH
SV	REVERSING VALVE
TP	COMP. DISCHARGE TEMP. SENSOR
T3	OUTDOOR COIL TEMP. SENSOR
T4	OUTDOOR AMBIENT TEMP. SENSOR
COMP TOP	COMP. TOP OLP TEMP. SENSOR
T2B	INDOOR COIL OUTLET TEMP. SENSOR
XT1	TERMINAL BLOCK

Notes:  This symbol indicates the element is optional, the actual shape shall be prevail.

M30C-27HFN8-Q

CODE: 16022000041432

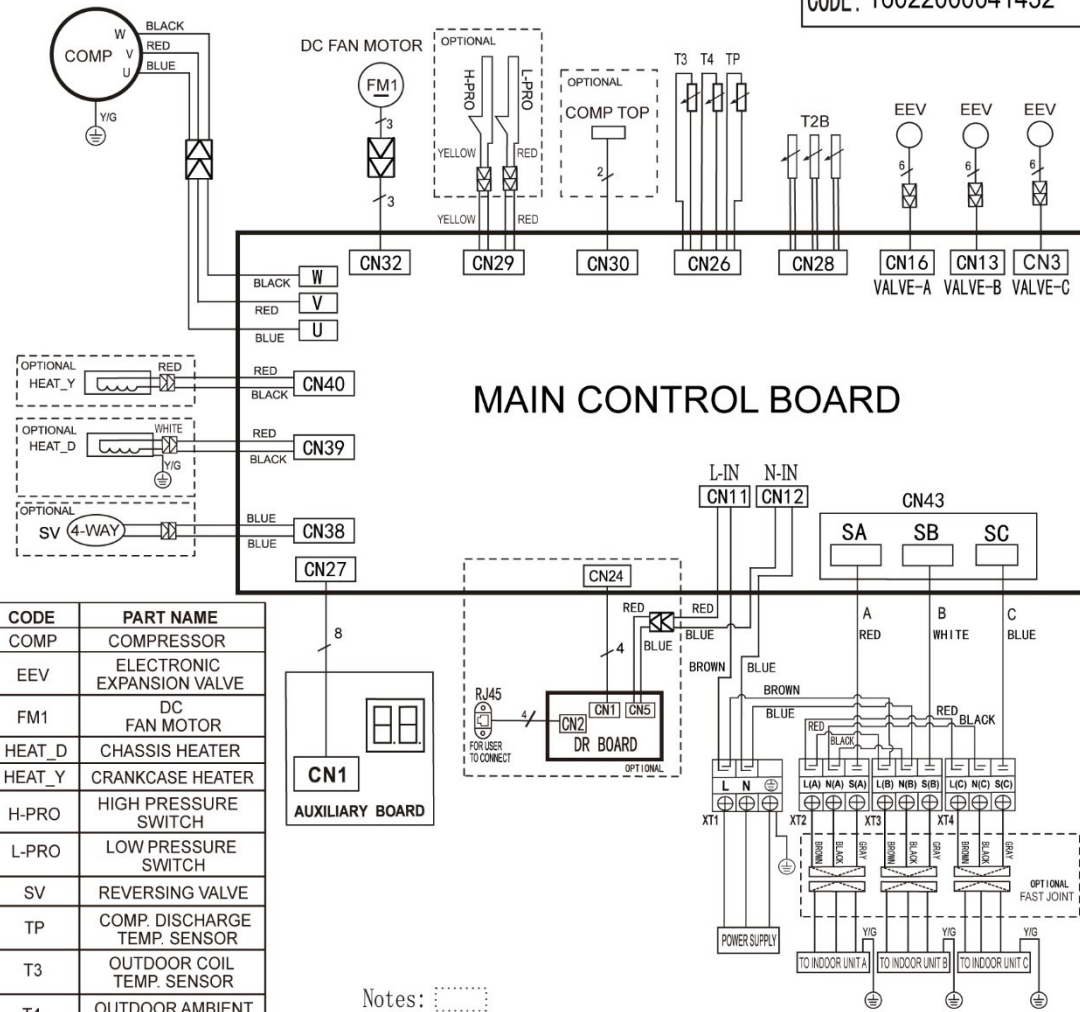

CODE	PART NAME
COMP	COMPRESSOR
EEV	ELECTRONIC EXPANSION VALVE
FM1	DC FAN MOTOR
HEAT_D	CHASSIS HEATER
HEAT_Y	CRANKCASE HEATER
H-PRO	HIGH PRESSURE SWITCH
L-PRO	LOW PRESSURE SWITCH
SV	REVERSING VALVE
TP	COMP. DISCHARGE TEMP. SENSOR
T3	OUTDOOR COIL TEMP. SENSOR
T4	OUTDOOR AMBIENT TEMP. SENSOR
COMP TOP	COMP. TOP OLP TEMP. SENSOR
T2B	INDOOR COIL OUTLET TEMP. SENSOR
XT1~4	TERMINAL BLOCK

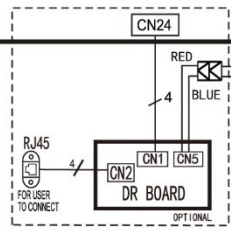
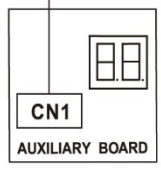

Notes:
 This symbol indicates the element is optional, the actual shape shall be prevail.

M30A-18HFN8-Q

WIRING DIAGRAM

16022300005493

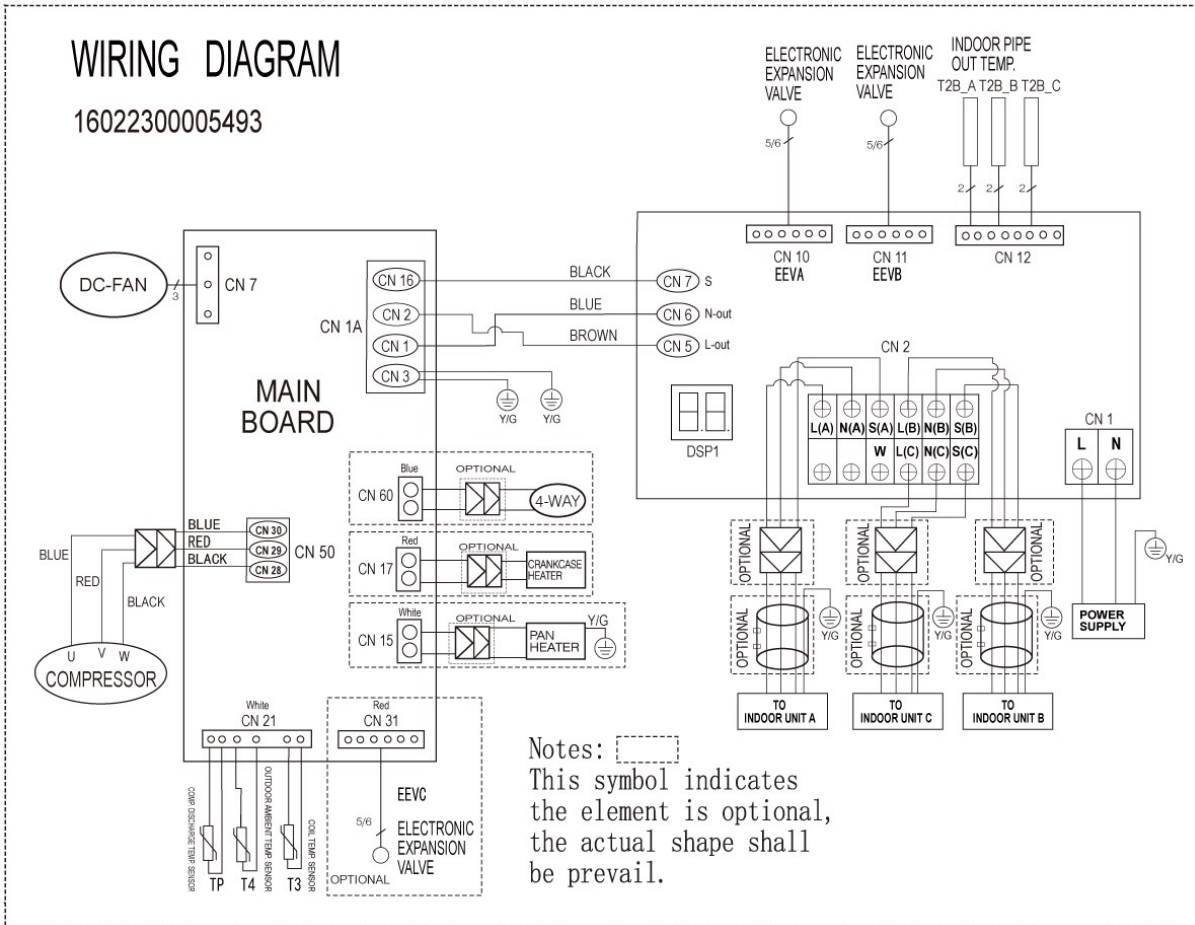

Notes:
 This symbol indicates the element is optional, the actual shape shall be prevail.

M30E-27HFN8-Q

16022300001533

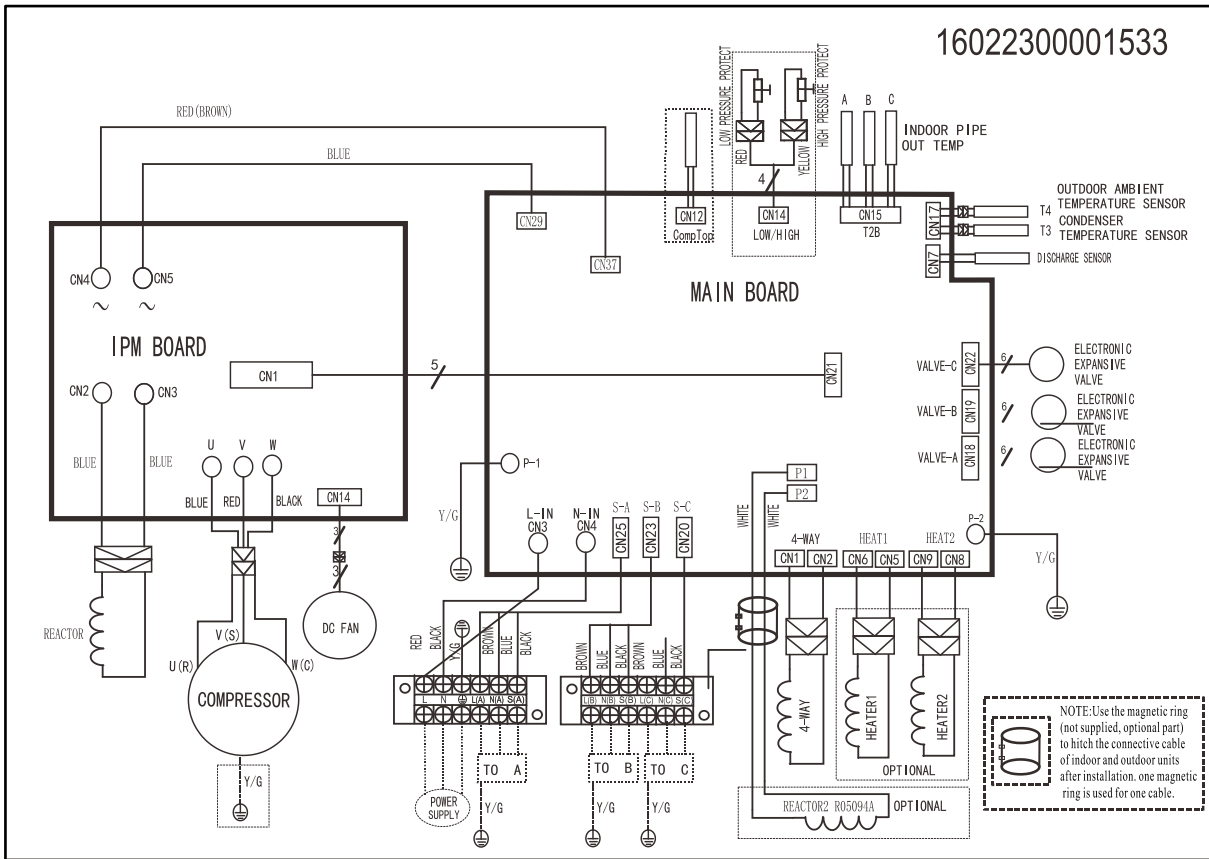

NOTE: Use the magnetic ring (not supplied, optional part) to hitch the connective cable of indoor and outdoor units after installation. one magnetic ring is used for one cable.

M3OF-21HFN8-Q, M3OF-27HFN8-Q

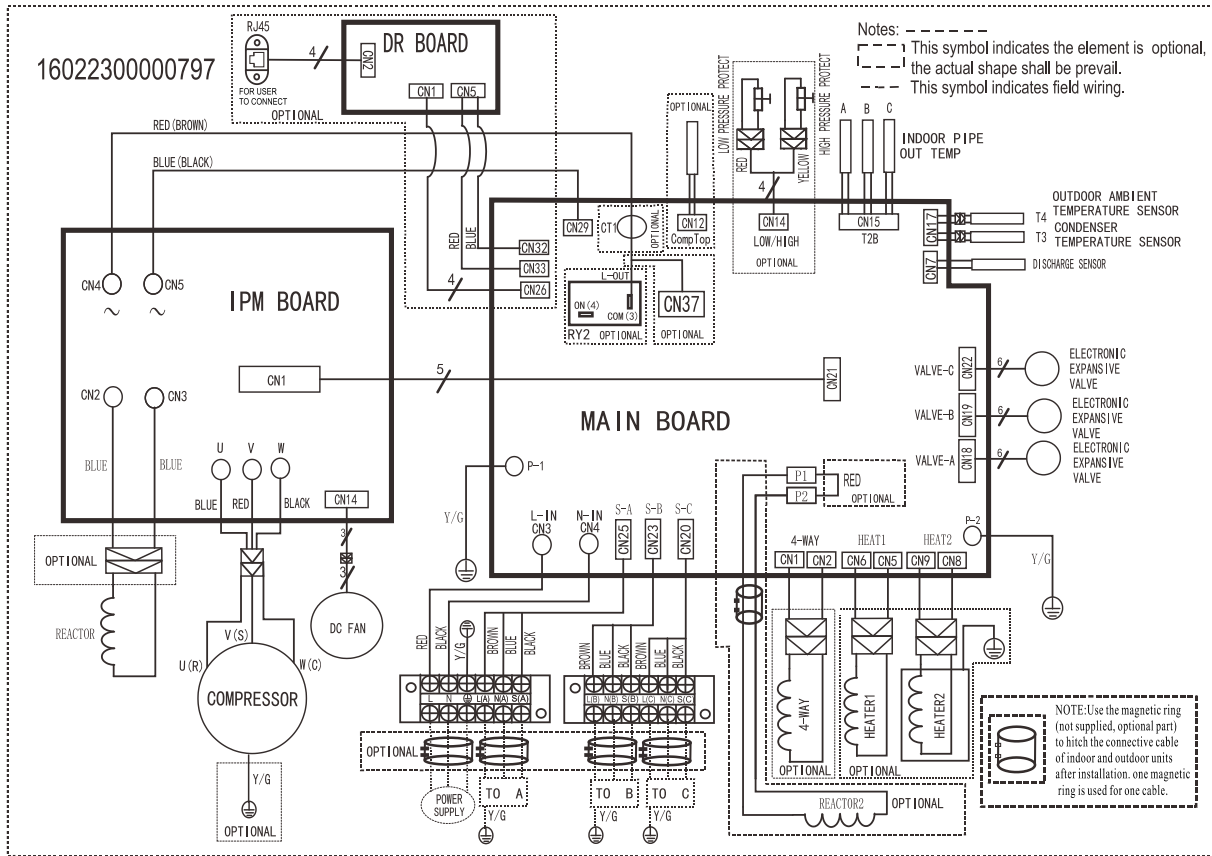

M3OG-21HFN8-Q, M3OA-27HFN8-Q

CODE: 16022000035910

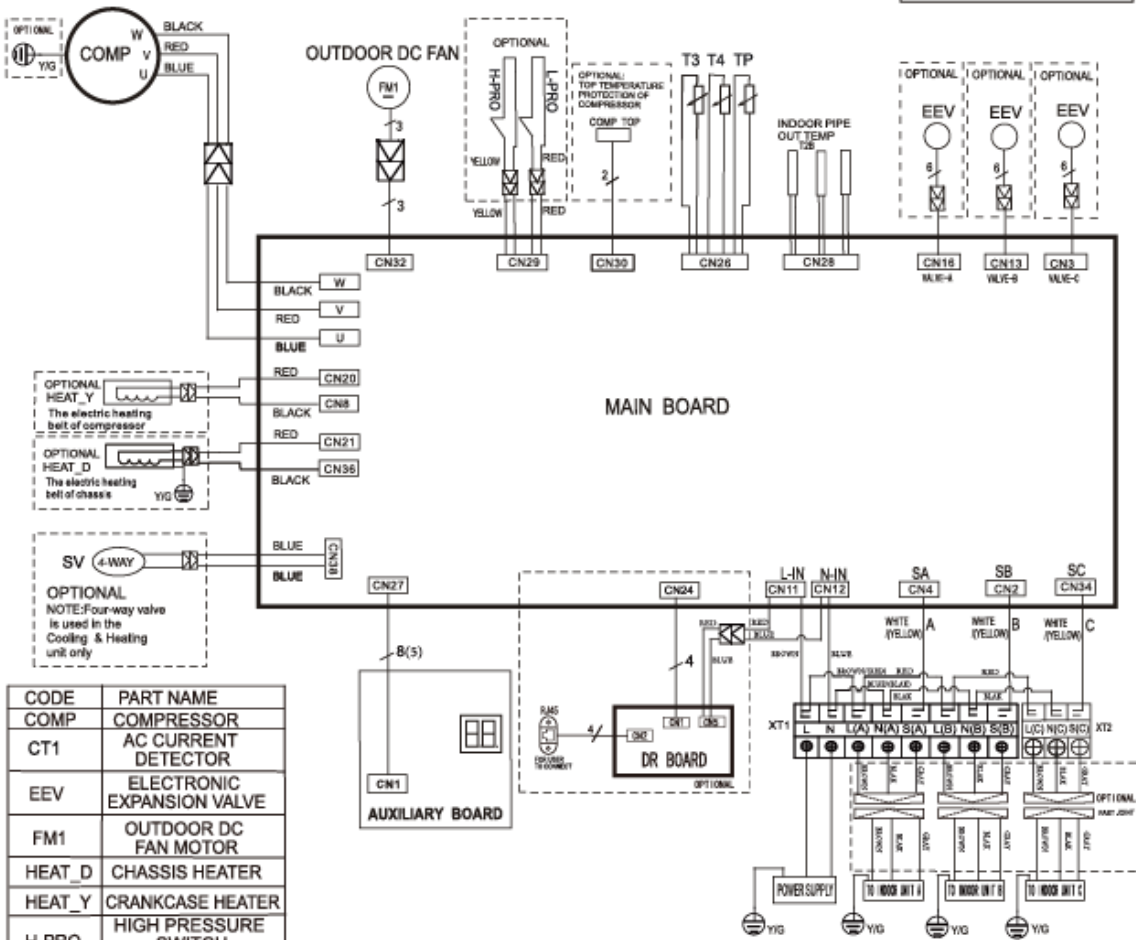

CODE	PART NAME
COMP	COMPRESSOR
CT1	AC CURRENT DETECTOR
EEV	ELECTRONIC EXPANSION VALVE
FM1	OUTDOOR DC FAN MOTOR
HEAT_D	CHASSIS HEATER
HEAT_Y	CRANKCASE HEATER
H-PRO	HIGH PRESSURE SWITCH
L-PRO	LOW PRESSURE SWITCH
SV	REVERSE VALVE
TP	COMP. DISCHARGE TEMP. SENSOR
T3	COIL TEMP. SENSOR
T4	OUTDOOR AMBIENT TEMP. SENSOR
COMP TOP	COMP. TOP OLP TEMP. SENSOR

Notes:
 This symbol indicates the element is optional, the actual shape shall be prevail.

M3OB-27HFN8-Q

CODE: 16022300004613

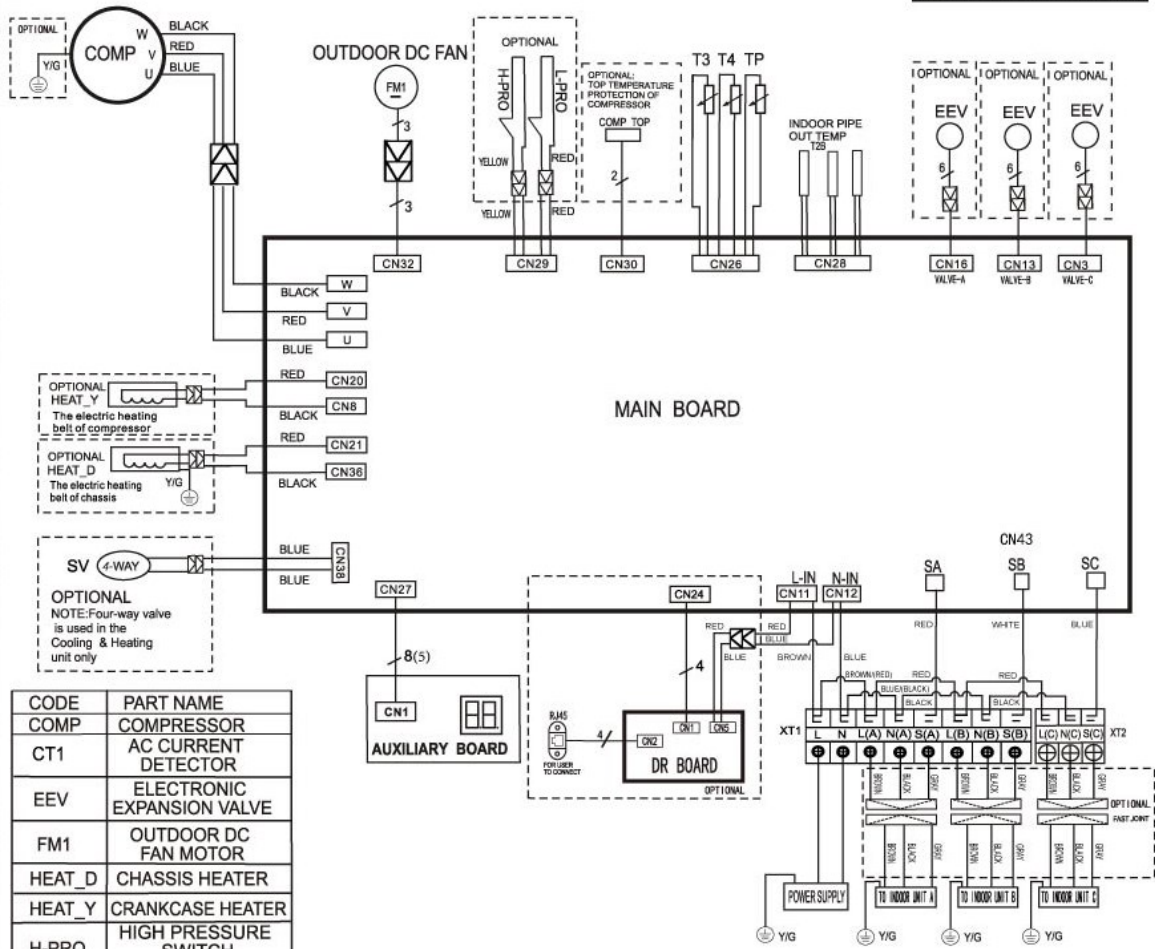

CODE	PART NAME
COMP	COMPRESSOR
CT1	AC CURRENT DETECTOR
EEV	ELECTRONIC EXPANSION VALVE
FM1	OUTDOOR DC FAN MOTOR
HEAT_D	CHASSIS HEATER
HEAT_Y	CRANKCASE HEATER
H-PRO	HIGH PRESSURE SWITCH
L-PRO	LOW PRESSURE SWITCH
SV	REVERSE VALVE
TP	COMP. DISCHARGE TEMP. SENSOR
T3	COIL TEMP. SENSOR
T4	OUTDOOR AMBIENT TEMP. SENSOR
COMP TOP	COMP. TOP OLP TEMP. SENSOR

Notes:
 This symbol indicates the element is optional, the actual shape shall be prevail.

M40A-24HFN8-Q

CODE: 16022000042340

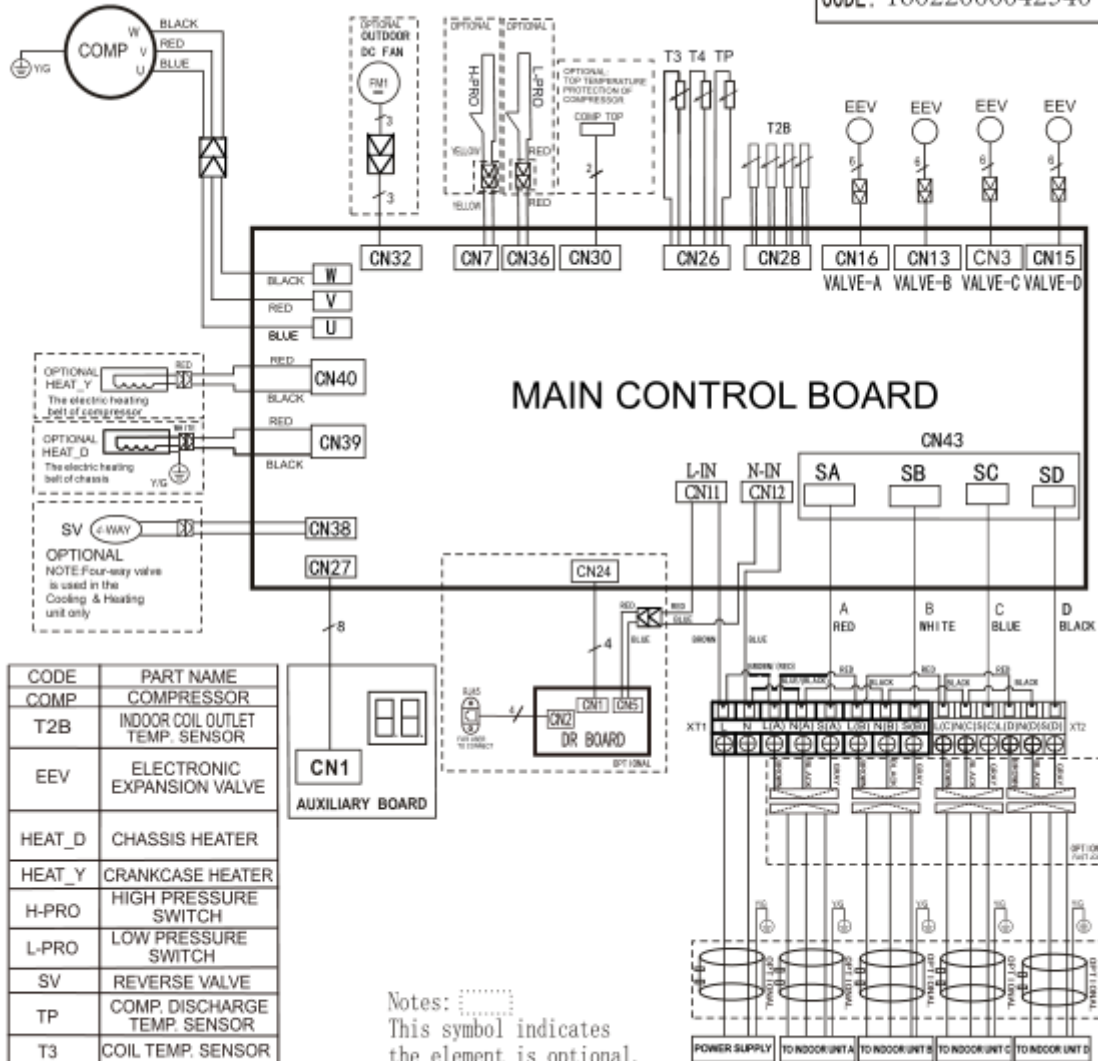

CODE	PART NAME
COMP	COMPRESSOR
T2B	INDOOR COIL OUTLET TEMP. SENSOR
EEV	ELECTRONIC EXPANSION VALVE
HEAT_D	CHASSIS HEATER
HEAT_Y	CRANKCASE HEATER
H-PRO	HIGH PRESSURE SWITCH
L-PRO	LOW PRESSURE SWITCH
SV	REVERSE VALVE
TP	COMP. DISCHARGE TEMP. SENSOR
T3	COIL TEMP. SENSOR
T4	OUTDOOR AMBIENT TEMP. SENSOR
COMP TOP	COMP. TOP OLP TEMP. SENSOR

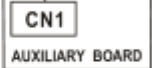

Notes:
 This symbol indicates the element is optional, the actual shape shall be prevail.

M4OB-36HFN8-Q

16022000037232

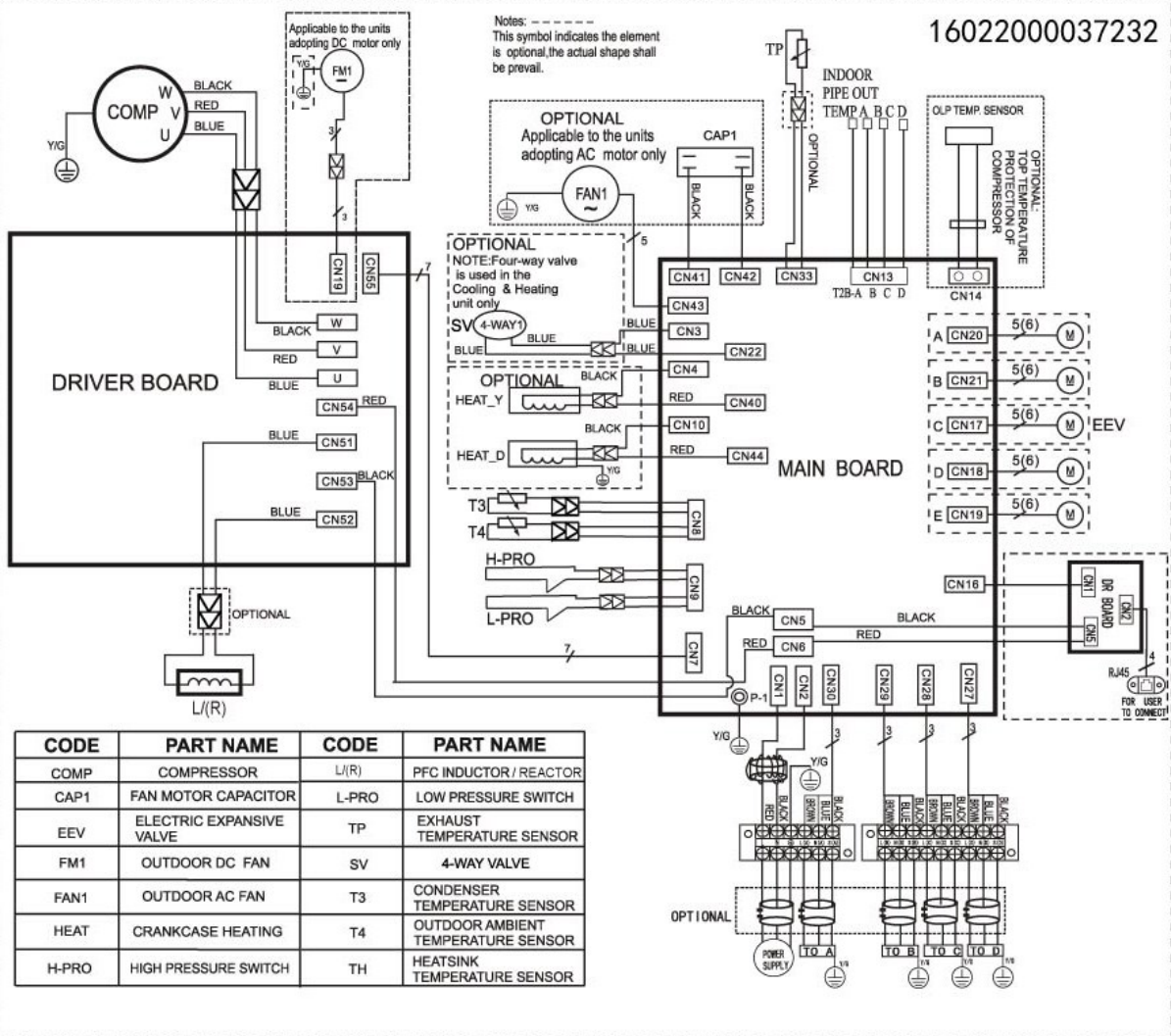

CODE: 16022000038970

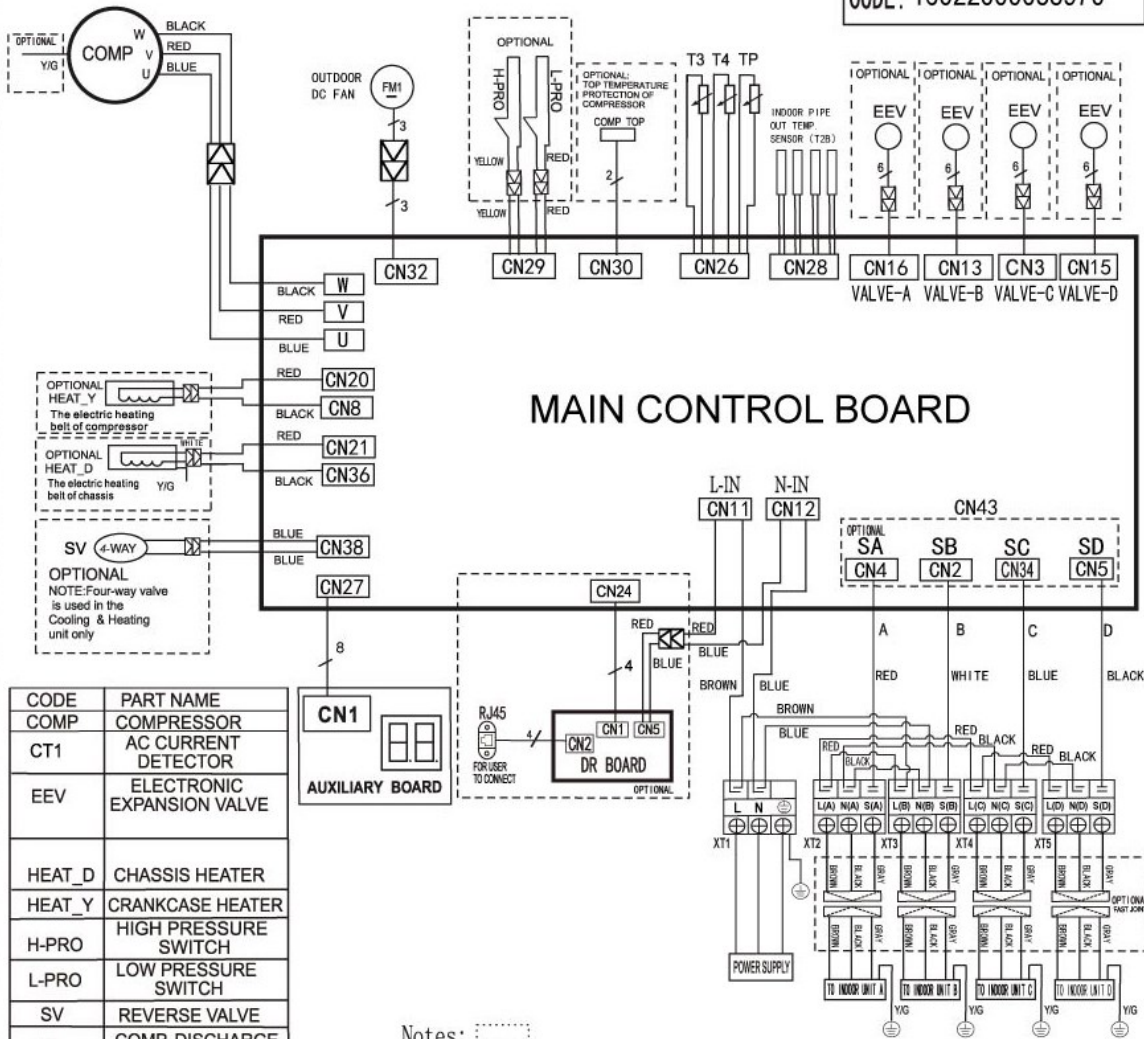

CODE	PART NAME
COMP	COMPRESSOR
CT1	AC CURRENT DETECTOR
EEV	ELECTRONIC EXPANSION VALVE
HEAT_D	CHASSIS HEATER
HEAT_Y	CRANKCASE HEATER
H-PRO	HIGH PRESSURE SWITCH
L-PRO	LOW PRESSURE SWITCH
SV	REVERSE VALVE
TP	COMP. DISCHARGE TEMP. SENSOR
T3	COIL TEMP. SENSOR
T4	OUTDOOR AMBIENT TEMP. SENSOR
COMP TOP	COMP. TOP OLP TEMP. SENSOR

Notes:
 This symbol indicates the element is optional, the actual shape shall be prevail.

M50D-42HFN8-Q, M50E-42HFN8-Q

1602230000795

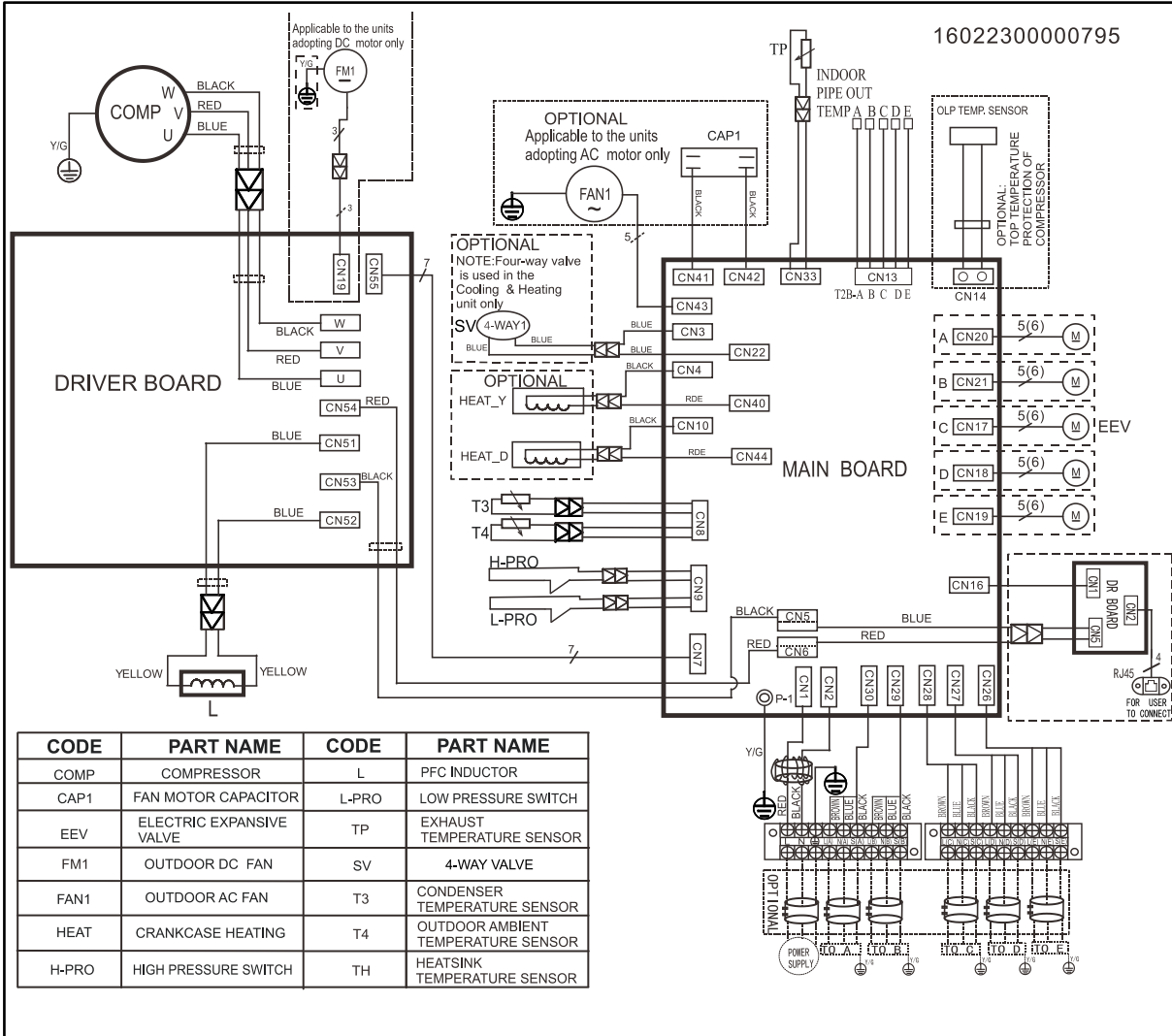

CODE: 16022000045190

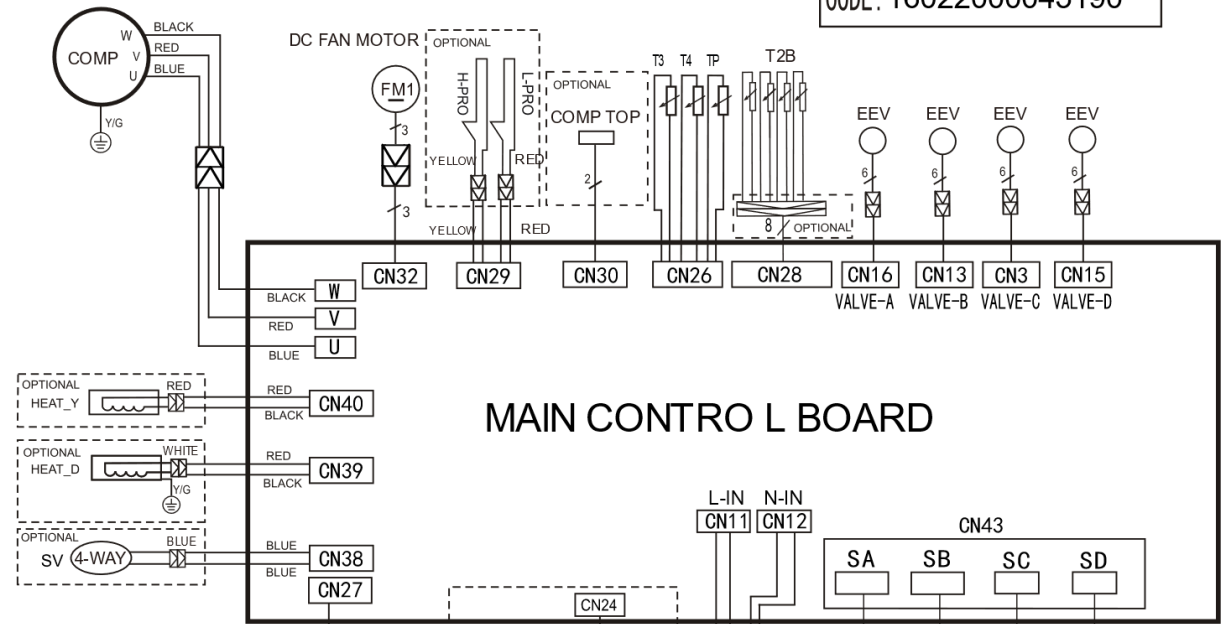

CODE	PART NAME
COMP	COMPRESSOR
EEV	ELECTRONIC EXPANSION VALVE
FM1	DC FAN MOTOR
HEAT_D	CHASSIS HEATER
HEAT_Y	CRANKCASE HEATER
H-PRO	HIGH PRESSURE SWITCH
L-PRO	LOW PRESSURE SWITCH
SV	REVERSING VALVE
TP	COMP. DISCHARGE TEMP. SENSOR
T3	OUTDOOR COIL TEMP. SENSOR
T4	OUTDOOR AMBIENT TEMP. SENSOR
COMPT OP	COMP. TOP OLP TEMP. SENSOR
T2B	INDOOR COIL OUTLET TEMP. SENSOR
XT1-5	TERMINAL BLOCK

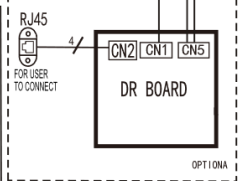
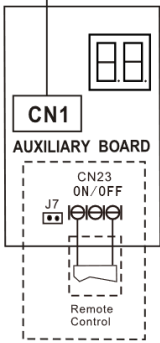

NOTE:
 1. This symbol indicates the element is optional the actual shape shall prevail.
 2. Remove the short connector of J7 when you use the "on-off" function.

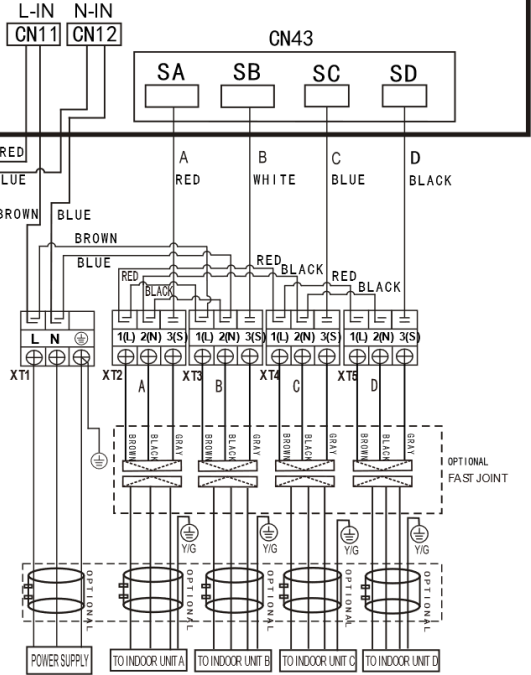

CODE: 16022300008333

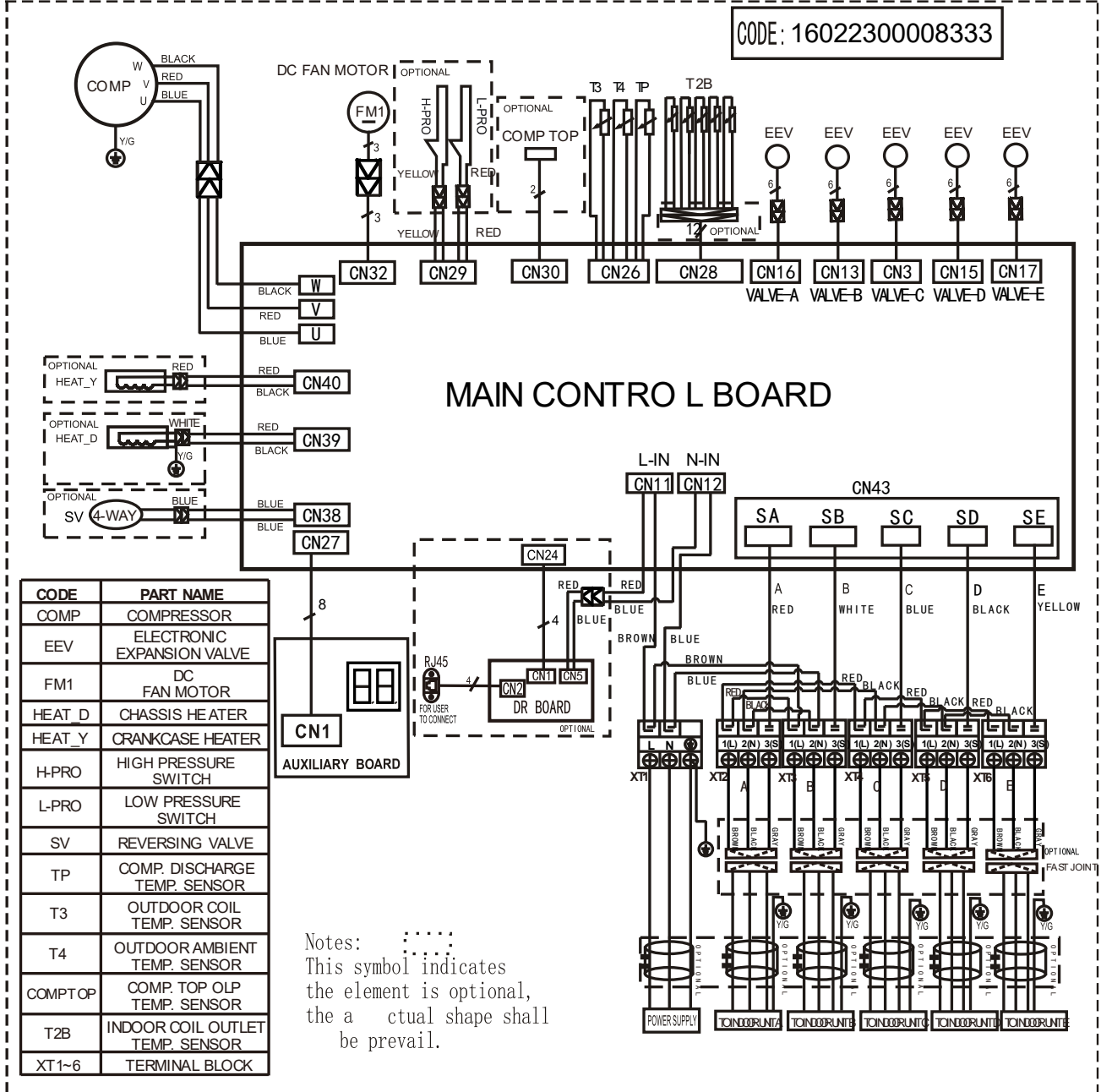

CODE	PART NAME
COMP	COMPRESSOR
EEV	ELECTRONIC EXPANSION VALVE
FM1	DC FAN MOTOR
HEAT_D	CHASSIS HEATER
HEAT_Y	CRANKCASE HEATER
H-PRO	HIGH PRESSURE SWITCH
L-PRO	LOW PRESSURE SWITCH
SV	REVERSING VALVE
TP	COMP. DISCHARGE TEMP. SENSOR
T3	OUTDOOR COIL TEMP. SENSOR
T4	OUTDOOR AMBIENT TEMP. SENSOR
COMPTOP	COMP. TOP OLP TEMP. SENSOR
T2B	INDOOR COIL OUTLET TEMP. SENSOR
XT1-6	TERMINAL BLOCK

Notes:
 This symbol indicates the element is optional, the actual shape shall be prevail.

CODE: 16022000042230

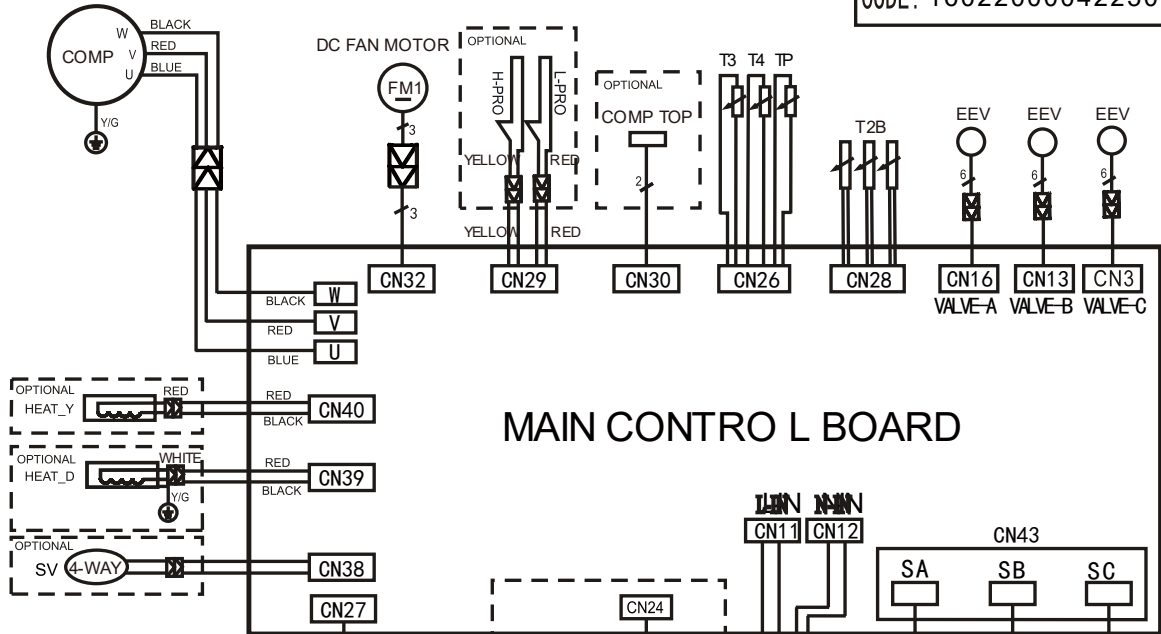

MAIN CONTROL BOARD

CODE	PART NAME
COMP	COMPRESSOR
EEV	ELECTRONIC EXPANSION VALVE
FM1	DC FAN MOTOR
HEAT_D	CHASSIS HEATER
HEAT_Y	CRANKCASE HEATER
H-PRO	HIGH PRESSURE SWITCH
L-PRO	LOW PRESSURE SWITCH
SV	REVERSING VALVE
TP	COMP. DISCHARGE TEMP. SENSOR
T3	OUTDOOR COL. TEMP. SENSOR
T4	OUTDOOR AMBIENT TEMP. SENSOR
COMP TOP	COMP. TOP OLP TEMP. SENSOR
T2B	INDOOR COIL OUTLET TEMP. SENSOR
XT1~2	TERMINAL BLOCK

Notes:
 This symbol indicates the element is optional, the actual shape shall be prevail.

6. Indoor unit combination

Note: The combination of yellow background is only suitable for GLORY PRO, XTREME, Forest, BREEZELESS E, ALL EASY PRO, Aurora, All Easy wall mounted type.

6.1 Indoor unit combination for M2OG-14HFN8-Q

One unit	Two units	
7	7+7	9+9
9	7+9	9+12
12	7+12	
18		

6.2 Indoor unit combination for M2OH-14HFN8-Q

One unit	Two units		
9	7+7	7+12	9+12
12	7+9	9+9	12+12

6.3 Indoor unit combination for M2OC-18HFN8-Q& M2OD-18HFN8-Q

One unit	Two units	
7	7+7	9+9
9	7+9	9+12
12	7+12	12+12
18		

6.4 Indoor unit combination for M2OE-18HFN8-Q

One unit	Two units		
9	7+7	7+18	9+18
12	7+9	9+9	12+12
18	7+12	9+12	12+18

6.5 Indoor unit combination for M2OF-18HFN8-Q

One unit	Two units		
12	7+7	7+18	9+18
18	7+9	9+9	12+12
	7+12	9+12	12+18

6.6 Indoor unit combination for M3OA-18HFN8-Q

One unit	Two units			Three units		
12	7+7	7+18	9+18	7+7+7	7+9+12	9+12+12
18	7+9	9+9	12+12	7+7+9	7+12+12	12+12+12
	7+12	9+12	12+18	7+7+12	9+9+9	
				7+9+9	9+9+12	

6.7 Indoor unit combination for M3OF-21HFN8-Q

One unit	Two units		Three units	
7	7+7	9+9	7+7+7	7+9+9
9	7+9	9+12	7+7+9	9+9+9
12	7+12	9+18	7+7+12	
18	7+18	12+12		

6.8 Indoor unit combination for M3OG-21HFN8-Q

One unit	Two units			Three units		
12	7+7	7+18	9+18	7+7+7	7+9+12	9+12+12
18	7+9	9+9	12+12	7+7+9	7+12+12	12+12+12
24	7+12	9+12	12+18	7+7+12	9+9+9	
				7+9+9	9+9+12	

6.9 Indoor unit combination for M3OE-27HFN8-Q, M3OF-27HFN8-Q

One unit	Two units			Three units		
7	7+7	7+18	9+18	7+7+7	7+9+12	9+12+12
9	7+9	9+9	12+12	7+7+9	7+12+12	12+12+12
12	7+12	9+12	12+18	7+7+12	9+9+9	
18				7+9+9	9+9+12	

6.10 Indoor unit combination for M3OA-27HFN8-Q& M3OB-27HFN8-Q& M3OD-27HFN8-Q

One unit	Two units			Three units			
12	7+7	7+18	9+18	7+7+7	7+9+9	7+12+18	9+12+12
18	7+9	9+9	12+12	7+7+9	7+9+12	9+9+9	9+12+18
24	7+12	9+12	12+18	7+7+12	7+9+18	9+9+12	12+12+12
			18+18	7+7+18	7+12+12	9+9+18	12+12+18

6.11 Indoor unit combination for M3OC-27HFN8-Q

Two units			Three units				
7+12	9+18	18+18	7+7+7	7+9+9	7+12+18	9+9+18	9+18+18
7+18	9+24	18+24	7+7+9	7+9+12	7+12+24	9+9+24	12+12+12
7+24	12+12		7+7+12	7+9+18	7+18+18	9+12+12	12+12+18
9+9	12+18		7+7+18	7+9+24	9+9+9	9+12+18	12+12+24
9+12	12+24		7+7+24	7+12+12	9+9+12	9+12+24	12+18+18

6.12 Indoor unit combination for M4OA-24HFN8-Q

One unit	Two units		Three units				Four units		
	18	7+7	9+12	7+7+7	7+9+9	7+12+18	9+12+12	7+7+7+7	7+7+9+18
24	7+9	9+18	7+7+9	7+9+12	9+9+9	9+12+18	7+7+7+9	7+7+12+12	9+9+9+12
	7+12	12+12	7+7+12	7+9+18	9+9+12	12+12+12	7+7+7+12	7+9+9+9	9+9+12+12
	7+18	12+18	7+7+18	7+12+12	9+9+18	12+12+18	7+7+7+18	7+9+9+12	9+12+12+12
	9+9	18+18					7+7+9+9	7+9+12+12	12+12+12+12
							7+7+9+12	7+12+12+12	

6.13 Indoor unit combination for M4OE-28HFN8-Q

Two units		Three units			Four units		
7+7	9+18	7+7+7	7+9+24	9+9+24	7+7+7+7	7+7+12+12	7+12+12+18
7+9	9+24	7+7+9	7+12+12	9+12+12	7+7+7+9	7+7+12+18	9+9+9+9
7+12	12+12	7+7+12	7+12+18	9+12+18	7+7+7+12	7+9+9+9	9+9+9+12
7+18	12+18	7+7+18	7+12+24	9+12+24	7+7+7+18	7+9+9+12	9+9+9+18
7+24	12+24	7+7+24	7+18+18	9+18+18	7+7+7+24	7+9+9+18	9+9+12+12
9+9	18+18	7+9+9	9+9+9	12+12+12	7+7+9+9	7+9+12+12	9+9+12+18
9+12	18+24	7+9+12	9+9+12	12+12+18	7+7+9+12	7+9+12+18	9+12+12+12
		7+9+18	9+9+18	12+18+18	7+7+9+18	7+12+12+12	12+12+12+12

6.14 Indoor unit combination for M4OB-36HFN8-Q& M4OC-36HFN8-Q&M4OD-36HFN8-Q

Two units		Three units				Four units			
7+12	9+24	7+7+7	7+9+18	9+9+9	9+12+24	7+7+7+7	7+7+9+18	7+9+12+12	9+9+12+12
7+18	12+12	7+7+9	7+9+24	9+9+12	9+18+18	7+7+7+9	7+7+9+24	7+9+12+18	9+9+12+18
7+24	12+18	7+7+12	7+12+12	9+9+18	12+12+12	7+7+7+12	7+7+12+12	7+12+12+12	9+12+12+12
9+9	12+24	7+7+18	7+12+18	9+9+24	12+12+18	7+7+7+18	7+7+12+18	7+12+12+18	9+12+12+18
9+12	18+18	7+7+24	7+12+24	9+12+12	12+12+24	7+7+7+24	7+9+9+9	9+9+9+9	12+12+12+12
9+18	18+24	7+9+9	7+18+18	9+12+18	12+18+18	7+7+9+9	7+9+9+12	9+9+9+12	12+12+12+18
		7+9+12				7+7+9+12	7+9+9+18	9+9+9+18	

6.15 Indoor unit combination for M5OE-42HFN8-Q&M5OG-42HFN8-Q

Two units		Three units			
7+18	12+12	7+7+7	7+9+18	9+9+9	9+18+18
7+24	12+18	7+7+9	7+9+24	9+9+12	9+18+24
9+9	12+24	7+7+12	7+12+12	9+9+18	12+12+12
9+12	18+18	7+7+18	7+12+18	9+9+24	12+12+18
9+18	18+24	7+7+24	7+12+24	9+12+12	12+12+24
9+24		7+9+9	7+18+18	9+12+18	12+18+18
		7+9+12	7+18+24	9+12+24	12+18+24
Four units					
7+7+7+7	7+7+9+12	7+9+9+9	7+9+12+24	9+9+9+18	9+12+12+18
7+7+7+9	7+7+9+18	7+9+9+12	7+12+12+12	9+9+9+24	9+12+12+24
7+7+7+12	7+7+9+24	7+9+9+18	7+12+12+18	9+9+12+12	12+12+12+12
7+7+7+18	7+7+12+12	7+9+9+24	7+12+12+24	9+9+12+18	12+12+12+18
7+7+7+24	7+7+12+18	7+9+12+12	9+9+9+9	9+9+12+24	12+12+12+24
7+7+9+9	7+7+12+24	7+9+12+18	9+9+9+12	9+12+12+12	
Five units					
7+7+7+7+7	7+7+7+9+24	7+7+9+12+12	7+9+9+9+18	7+12+12+12+12	9+9+9+12+24
7+7+7+7+9	7+7+7+12+12	7+7+9+12+18	7+9+9+9+24	7+12+12+12+18	9+9+12+12+12
7+7+7+7+12	7+7+7+12+18	7+7+9+12+24	7+9+9+12+12	9+9+9+9+9	9+9+12+12+18
7+7+7+7+18	7+7+7+12+24	7+7+12+12+12	7+9+9+12+18	9+9+9+9+12	9+9+12+12+24
7+7+7+7+24	7+7+9+9+9	7+7+12+12+18	7+9+9+12+24	9+9+9+9+18	9+12+12+12+12
7+7+7+9+9	7+7+9+9+12	7+7+12+12+24	7+9+12+12+12	9+9+9+9+24	9+12+12+12+18
7+7+7+9+12	7+7+9+9+18	7+9+9+9+9	7+9+12+12+18	9+9+9+12+12	12+12+12+12+12
7+7+7+9+18	7+7+9+9+24	7+9+9+9+12	7+9+12+12+24	9+9+9+12+18	12+12+12+12+18

6.16 Indoor unit combination for M5OD-42HFN8-Q

One Unit	Two units		Three units			
7	7+7	9+18	7+7+7	7+9+18	9+9+12	12+12+12
9	7+9	9+24	7+7+9	7+9+24	9+9+18	12+12+18
12	7+12	12+12	7+7+12	7+12+12	9+9+24	12+12+24
18	7+18	12+18	7+7+18	7+12+18	9+12+12	12+18+18
24	7+24	12+24	7+7+24	7+12+24	9+12+18	
	9+9	18+18	7+9+9	7+18+18	9+12+24	
	9+12		7+9+12	9+9+9	9+18+18	
Four units						
	7+7+7+7	7+7+9+18	7+9+9+12	7+12+12+12	9+9+12+18	
	7+7+7+9	7+7+9+24	7+9+9+18	7+12+12+18	9+9+12+24	
	7+7+7+12	7+7+12+12	7+9+9+24	9+9+9+9	9+12+12+12	
	7+7+7+18	7+7+12+18	7+9+12+12	9+9+9+12	9+12+12+18	
	7+7+7+24	7+7+12+24	7+9+12+18	9+9+9+18	12+12+12+12	
	7+7+9+9	7+7+18+18	7+9+12+24	9+9+9+24	12+12+12+18	
	7+7+9+12	7+9+9+9	7+9+18+18	9+9+12+12		
Five units						
	7+7+7+7+7	7+7+7+9+18	7+7+9+12+12	7+9+9+9+18	9+9+9+12+12	
	7+7+7+7+9	7+7+7+12+12	7+7+9+12+18	7+9+9+12+12	9+9+12+12+12	
	7+7+7+7+12	7+7+7+12+18	7+7+12+12+12	7+9+12+12+12		
	7+7+7+7+18	7+7+9+9+9	7+7+12+12+18	9+9+9+9+9		
	7+7+7+9+9	7+7+9+9+12	7+9+9+9+9	9+9+9+9+12		
	7+7+7+9+12	7+7+9+9+18	7+9+9+9+12	9+9+9+9+18		

6.8 ATW+ AC indoor (M3OB-27HFN8-Q, M4OB-36HFN8-Q, M4OC-36HFN8-Q& M5OE-42HFN8-Q)

M3OB-27HFN8-Q

One unit	Two units	Three units	
7	ATW+7	ATW+7+7	ATW+9+9
9	ATW+9	ATW+7+9	ATW+9+12
12	ATW+12	ATW+7+12	
ATW			

M4OB-36HFN8-Q

One unit	Two units	Three units		Four units		
7	ATW+7	ATW+7+7	ATW+9+12	ATW+7+7+7	ATW+7+9+12	ATW+9+12+12
9	ATW+9	ATW+7+9	ATW+9+18	ATW+7+7+9	ATW+7+9+18	ATW+9+12+18
12	ATW+12	ATW+7+12	ATW+12+12	ATW+7+7+12	ATW+9+9+9	ATW+12+12+12
18	ATW+18	ATW+7+18	ATW+12+18	ATW+7+7+18	ATW+9+9+12	ATW+12+12+18
ATW		ATW+9+9	ATW+18+18	ATW+7+9+9	ATW+9+9+18	

M4OC-36HFN8-Q

One unit	Two units	Three units		Four units		Limit
7	ATW+7	ATW+7+7	ATW+9+9	ATW+7+7+7	ATW+7+9+12	The indoor AC is shown in the table below
9	ATW+9	ATW+7+9	ATW+9+12	ATW+7+7+9	ATW+7+12+12	
12	ATW+12	ATW+7+12	ATW+12+12	ATW+7+7+12	ATW+9+9+9	
18	ATW+18			ATW+7+9+9	ATW+9+9+12	
ATW						

Aurora series	Infini series	Forest series	Glory Pro series	Compact cassette	New console
MSABAU-09HRFN8-QRD0GW	MSAGAU-09HRFNX-QRD0GW	MSAFBU-07HRDNX-QRD0GW	MSGPAU-07HRFN8-QRD1GW	MCA3U-07HRFNX-QRD0W(GA)	MFA2U-09HRFNX-QRD0W(GA)
MSABBU-12HRFNX-QRD0GW	MSAGBU-12HRFNX-QRD0GW	MSAFBU-09HRDN8-QRD0GW	MSGPAU-09HRFN8-QRD6GW	MCA3U-09HRFNX-QRD0W(GA)	MFA2U-12HRFNX-QRD0W(GA)
MSABDU-18HRFNX-QRD0GW	MSAGCU-18HRFNX-QRD0GW	MSAFBU-12HRDN8-QRD0GW	MSGPAU-09HRFN8-QRD1GW	MCA3U-12HRFNX-QRD0W(GA)	MFA2U-17HRFNX-QRD0W(GA)
MSABBU-09HRFN8-QRD6GW	MSAGBU-09HRFN8-QRD1GW(GA)	MSAFBU-18HRFN8-QRD0GW	MSGPBU-12HRFN8-QRD6GW	MCA3U-18HRFNX-QRD0W(GA)	MFA2U-09HRFNX-QRD0W(GA)
MSABBU-12HRFN8-QRD6GW	MSAGBU-12HRFN8-QRD1GW(GA)		MSGPBU-12HRFN8-QRD1GW		
	MSAGAU-09HRDN8-QRD0GW		MSGPBU-12HRFN8-QRD1GW[N]		
			MSGPBU-12HRFN8-QRD2GW		
			MSGPCU-18HRFN8-QRD6GW		
			MSGPCU-18HRFN8-QRD1GW		
			MSGPDU-24HRFN8-QRD6GW		
			MSGPDU-24HRFN8-QRD1GW		

M5OE-42HFN8-Q

One unit	Two units	Three units	Four units		Five units		
7	ATW+7	ATW+7+7	ATW+7+7+7	ATW+7+12+12	ATW+7+7+7+7	ATW+7+7+9+12	ATW+7+9+12+12
9	ATW+9	ATW+7+9	ATW+7+7+9	ATW+9+9+9	ATW+7+7+7+9	ATW+7+7+12+12	ATW+9+9+9+9
12	ATW+12	ATW+7+12	ATW+7+7+12	ATW+9+9+12	ATW+7+7+7+12	ATW+7+9+9+9	ATW+9+9+9+12
18	ATW+18	ATW+9+12	ATW+7+9+9	ATW+9+12+12	ATW+7+7+9+9	ATW+7+9+9+12	ATW+7+9+12+12
ATW		ATW+12+12	ATW+7+9+12	ATW+12+12+12	ATW+7+7+7+7	ATW+7+7+9+12	

Caution: ATW must be connected with A circulation pathways.

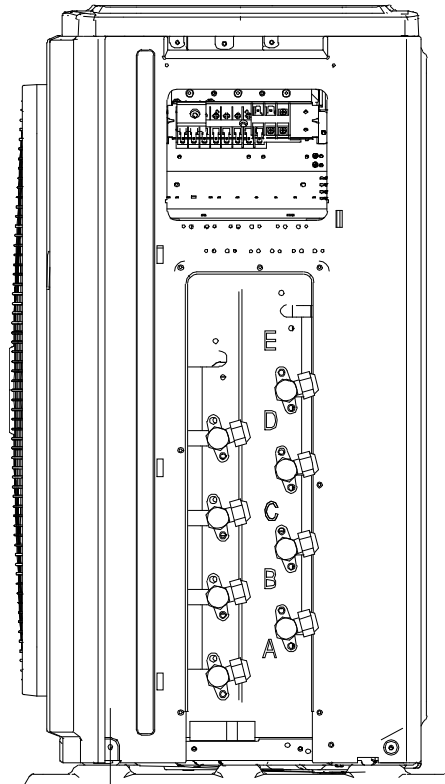

7. Sound Levels

Outdoor Unit

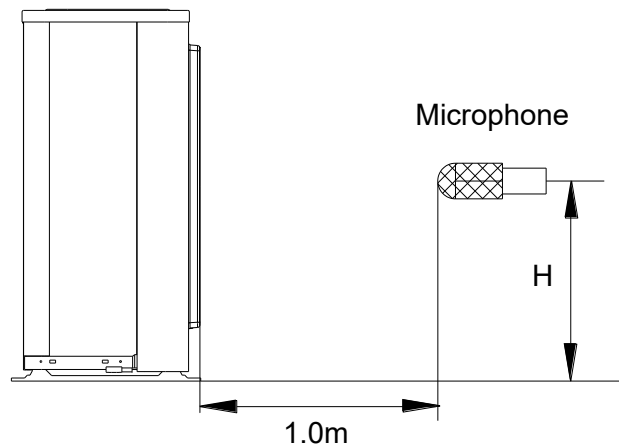

Note: $H = 0.5 \times$ height of outdoor unit

Model	Noise Power dB(A)	Noise level dB(A)
M2OG-14HFN8-Q	64	57
M2OC-18HFN8-Q	56	53
M2OD-18HFN8-Q	65	55.5
M3OA-18HFN8-Q	64	57
M3OF-21HFN8-Q	66	57.5
M3OE-27HFN8-Q	65	59
M3OF-27HFN8-Q	67	59.5
M4OE-28HFN8-Q	69	61
M4OB-36HFN8-Q	68	63
M5OD-42HFN8-Q	71	62
M5OE-42HFN8-Q	70	63
M2OH-14HFN8-Q	65	56
M2OE-18HFN8-Q	65	54
M2OF-18HFN8-Q	65	54
M3OC-27HFN8-Q	64	62
M3OG-21HFN8-Q	66	58
M3OA-27HFN8-Q	67	58
M3OB-27HFN8-Q	65	61.2
M3OD-27HFN8-Q	68	60
M4OC-36HFN8-Q	70	61.3
M4OA-24HFN8-Q	65	62
M4OD-36HFN8-Q	67	60
M5OG-42HFN8-Q	67	61

8. Installation Details

8.1 Wrench torque sheet for installation

Outside diameter	Torque	Additional tightening torque
mm	N.cm	N.cm
Φ6.35	1500(153kgf.cm)	1600(163kgf.cm)
Φ9.52	2500(255kgf.cm)	2600(265kgf.cm)
Φ12.7	3500(357kgf.cm)	3600(367kgf.cm)

8.2 Connecting the cables

The power cord of connect should be selected according to the following specifications sheet.

Rated current of appliance	Nominal cross-sectional area (mm ²)
>3 and ≤6	0.75
>6 and ≤10	1
>10 and ≤16	1.5
>16 and ≤25	2.5

The cable size and the current of the fuse or switch are determined by the maximum current indicated on the nameplate which located on the side panel of the unit. Please refer to the nameplate before selecting the cable, fuse and switch.

8.3 Pipe length and the elevation

1. Maximum piping length and height difference

	1 drive 2	1 drive 3	1 drive 4	1 drive 5
Max. length for all rooms (m)	40	60	80	80
Max. length for one IU (m)	25	30	35	35
Max. height difference between IU and OU (m)	15	15	15	15
Max. height difference between IUs (m)	10	10	10	10

* Example: ODU M3OG-21HFN8-Q, one indoor unit has an equivalent refrigerant pipe length of 30 metres, the second indoor unit has an equivalent refrigerant pipe length of 20 metres, no more than 10 metres of equivalent length will be left for the third indoor unit.

If the indoor unit include AC and ATW,

	1 drive 3	1 drive 4	1 drive 5
Max. length for one IU (m)	20	20	20
Max. height difference between IU and OU (m)	15	15	15
Max. height difference between IUs (m)	10	10	10

2. Oil traps

-If oil flows back into the outdoor unit's compressor, this might cause liquid compression or deterioration of oil return. Oil traps in the rising gas piping can prevent this.

-An oil trap should be installed every 6m(20ft) of vertical suction line riser (<36000Btu/h unit).

-An oil trap should be installed every 10m(32.8ft) of vertical suction line riser (\geq 36000Btu/h unit).

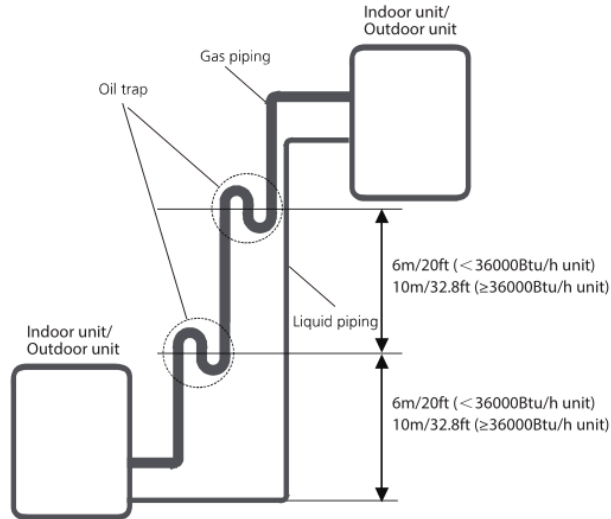

3. Additional refrigerant charge

Connective Pipe Length(m)	Additional refrigerant	
	\varnothing 6.35 (1/4")	\varnothing 9.52 (3/8")
Liquid Side		
Pre-charge pipe length (ft/m) (pre-charge pipe length xN)	N/A	
All the indoor unit is AC	(Total pipe length - pre-charge pipe length)xN) x12g(0.13oz)/m(ft)	(Total pipe length - pre-charge pipe length)xN) x24g(0.26oz)/m(ft)
The indoor unit include AC and ATW	Total pipe length-standard pipe length)x20g(0.22oz)/m(ft)	(Total pipe length-standard pipe length)x32g(0.35oz)/m(ft)
The indoor unit only is ATW	No need adding refrigerant	/

Caution:

- Refrigerant pipe diameter is different according to indoor unit to be connected. When using the extension pipe, refer to the tables below.
- When refrigerant pipe diameter is different from that of outdoor unit union (for 18K&24K indoor unit), additional transfer connector needs to be used on outdoor unit union.

Indoor unit			Extension pipe diameter (mm/inch)	
Model	Pipe diameter (mm/inch)			
7K9K12K	Liquid	6.35(1/4)	Liquid	6.35(1/4)
	Gas	9.52(3/8)	Gas	9.52(3/8)
18K	Liquid	6.35(1/4)	Liquid	6.35(1/4)
	Gas	12.7(1/2)	Gas	12.7(1/2)

24K	Liquid	9.52(3/8)	Liquid	9.52(3/8)
	Gas	15.9(5/8)	Gas	15.9(5/8)
Outdoor unit union diameter (mm/inch)				
1 drive 2	Liquid	6.35(1/4) *2		
	Gas	9.52(3/8) *2		
1 drive 3(M3OC-27HFN8-Q)	Liquid	6.35(1/4) *3		
	Gas	9.52(3/8) *2		
		12.7(1/2) *1		
1 drive 3(other models)	Liquid	6.35(1/4) *3		
	Gas	9.52(3/8) *3		
1 drive 4(M4OA-24HFN8-Q)	Liquid	6.35(1/4) *4		
	Gas	9.52(3/8) *4		
1 drive 4(other models)	Liquid	6.35(1/4) *4		
	Gas	9.52(3/8) *3		
		12.7(1/2) *1		
1 drive 5	Liquid	6.35(1/4) *5		
	Gas	9.52(3/8) *4		
		12.7(1/2) *1		

8.4 Installation for the first time

Air and moisture in the refrigerant system have undesirable effects as below:

- Pressure in the system rises.
- Operating current rises.
- Cooling or heating efficiency drops.
- Moisture in the refrigerant circuit may freeze and block capillary tubing.
- Water may lead to corrosion of parts in the refrigerant system.

Therefore, the indoor units and the pipes between indoor and outdoor units must be leak tested and evacuated to remove gas and moisture from the system.

Gas leak check (Soap water method):

Apply soap water or a liquid neutral detergent on the indoor unit connections or outdoor unit connections by a soft brush to check for leakage of the connecting points of the piping. If bubbles come out, the pipes have leakage.

1. Air purging with vacuum pump

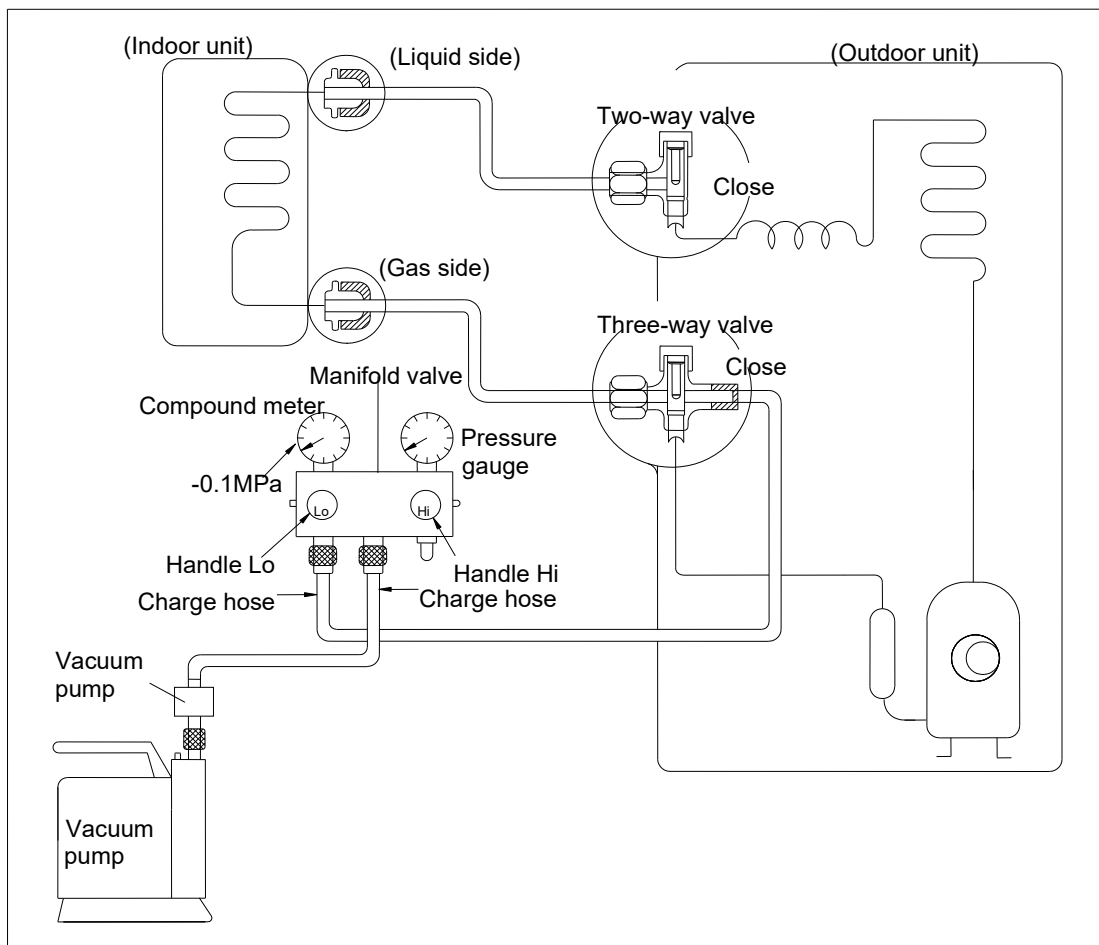

- 1) Completely tighten the flare nuts of the indoor and outdoor units, confirm that both the 2-way and 3-way valves are set to the closed position.
- 2) Connect the charge hose with the push pin of handle lo to the 3-way valves gas service port..
- 3) Connect the charge hose of handle hi connection to the vacuum pump.
- 4) Fully open the handle Lo of the manifold valve.
- 5) Operate the vacuum pump to evacuate.
- 6) Make evacuation for 30 minutes and check whether the compound meter indicates -0.1Mpa. If the meter does not indicate -0.1Mpa after pumping 30 minutes, it should be pumped 20 minutes more. If the pressure can't achieve -0.1Mpa after pumping 50 minutes, please check if there are some leakage points. Fully close the handle Lo valve of the manifold valve and stop the operation of the vacuum pump. Confirm that the gauge needle does not move (approximately 5 minutes after turning off the vacuum pump).
- 7) Turn the flare nut of the 3-way valves about 45° counterclockwise for 6 or 7seconds after the gas

coming out, then tighten the flare nut again. Make sure the pressure display in the pressure indicator is a little higher than the atmosphere pressure. Then remove the charge hose from the 3 way valve.

8) Fully open the 2 way valve and 3 way valve and securely tighten the cap of the 3 way valve.

2. Adding the refrigerant if the pipe length >5m

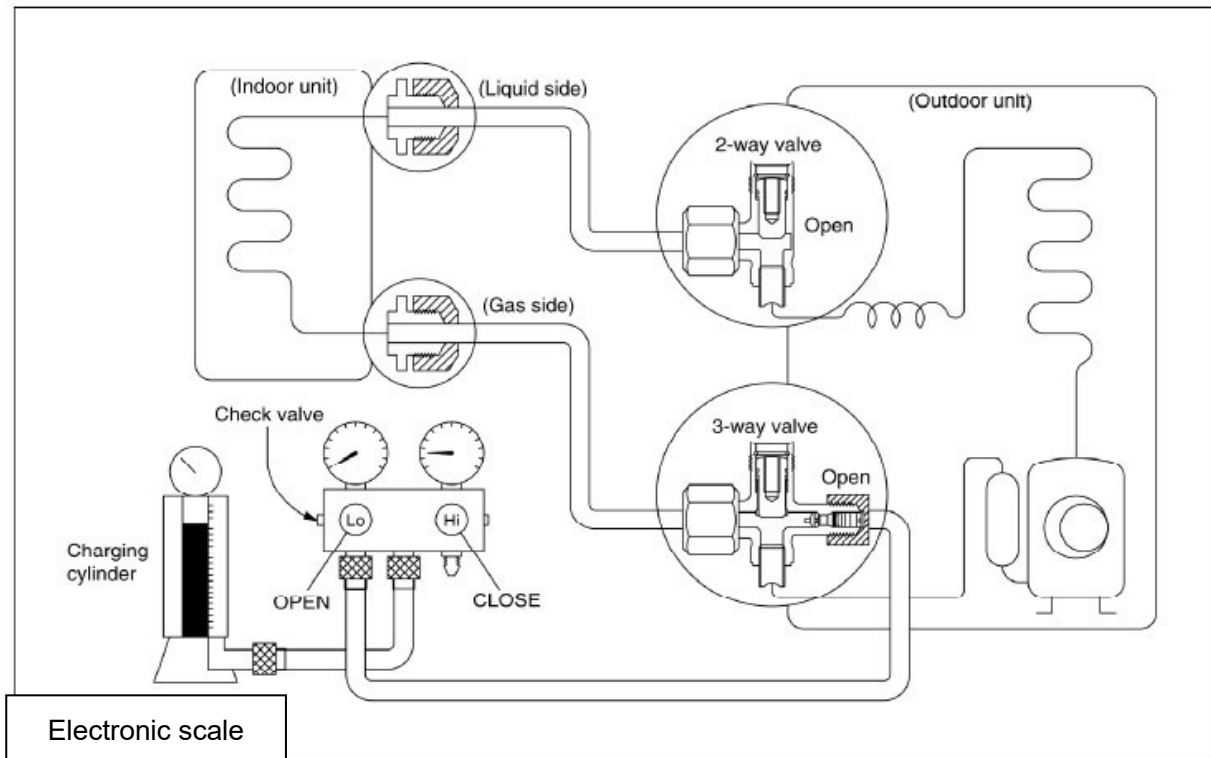

Procedure:

- 1). Connect the charge hose to the charging cylinder, open the 2-way valve and the 3-way valve.
Connect the charge hose which you disconnected from the vacuum pump to the valve at the bottom of the cylinder. If the refrigerant is R410A, make the cylinder bottom up to ensure the liquid charge.
- 2). Purge the air from the charge hose.
Open the valve at the bottom of the cylinder and press the check valve on the charge set to purge the air (be careful of the liquid refrigerant).
- 3) Put the charging cylinder onto the electronic scale and record the weight.
- 4) Operate the air conditioner at the cooling mode.
- 5) Open the valves (Low side) on the charge set and charge the system with liquid refrigerant.
- 6).When the electronic scale displays the proper weight (refer to the table), disconnect the charge hose from the 3-way valve's service port immediately and turn off the air conditioner before disconnecting the hose.
- 7). Mount the valve stem caps and the service port
Use torque wrench to tighten the service port cap to a torque of 18N.m.
Be sure to check for gas leakage.

8.5 Adding the refrigerant after running the system for many years

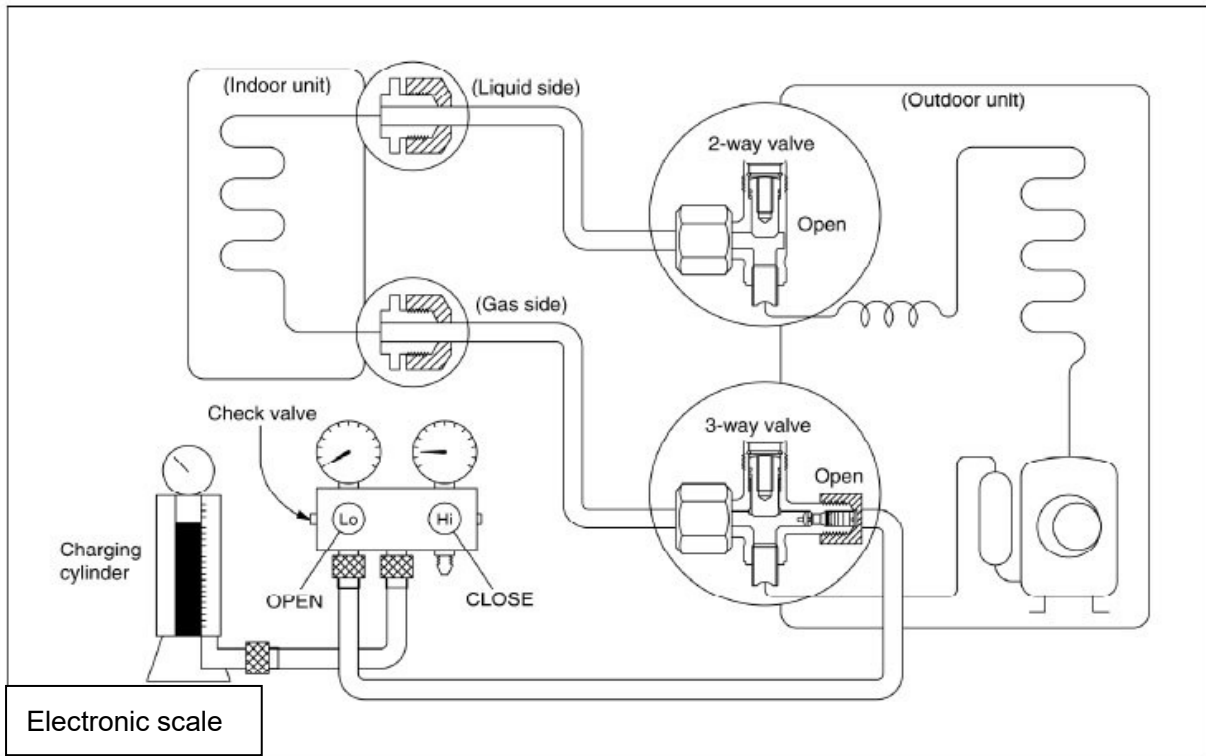

Procedure:

- 1). Connect the charge hose to the 3-way service port, open the 2-way valve and the 3-way valve. Connect the charge hose to the valve at the bottom of the cylinder. If the refrigerant is R410A, make the cylinder bottom up to ensure liquid charge.
- 2). Purge the air from the charge hose.
Open the valve at the bottom of the cylinder and press the check valve on the charge set to purge the air (be careful of the liquid refrigerant).
- 3) Put the charging cylinder onto the electronic scale and record the weight.
- 4) Operate the air conditioner at the cooling mode.
- 5) Open the valves (Low side) on the charge set and charge the system with liquid refrigerant.
- 6).When the electronic scale displays the proper weight (refer to the gauge and the pressure of the low side), disconnect the charge hose from the 3-way valve's service port immediately and turn off the air conditioner before disconnecting the hose.
- 7). Mount the valve stem caps and the service port
Use torque wrench to tighten the service port cap to a torque of 18N.m.
Be sure to check for gas leakage.

8.6 Re-installation while the indoor unit need to be repaired

1. Collecting the refrigerant into the outdoor unit

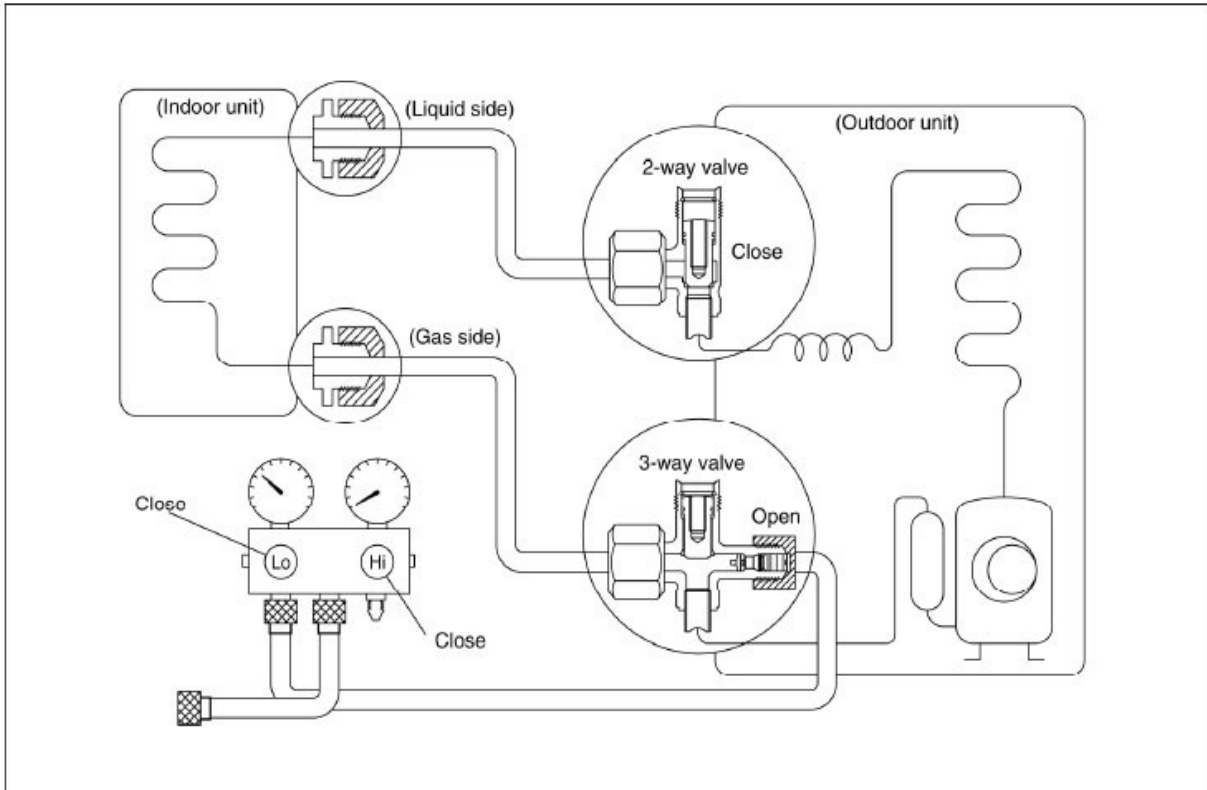

Procedure

- 1). Confirm that both the 2-way and 3-way valves are set to the opened position
Remove the valve stem caps and confirm that the valve stems are in the opened position.
Be sure to use a hexagonal wrench to operate the valve stems.
- 2). Connect the charge hose with the push pin of handle lo to the 3-way valves gas service port.
- 3). Air purging of the charge hose.
Open the handle Lo valve of the manifold valve slightly to purge air from the charge hose for 5 seconds and then close it quickly.
- 4). Set the 2-way valve to the close position.
- 5). Operate the air conditioner at the cooling cycle and stop it when the gauge indicates 0.1MPa.
- 6). Set the 3-way valve to the closed position immediately
Do this quickly so that the gauge ends up indicating 0.3 to 0.5Mpa.
Disconnect the charge set, and tighten the 2-way and 3-way valve's stem nuts.
Use a torque wrench to tighten the 3-way valves service port cap to a torque of 1.8 kgf.m.
Be sure to check for gas leakage.

2. Air purging with vacuum pump

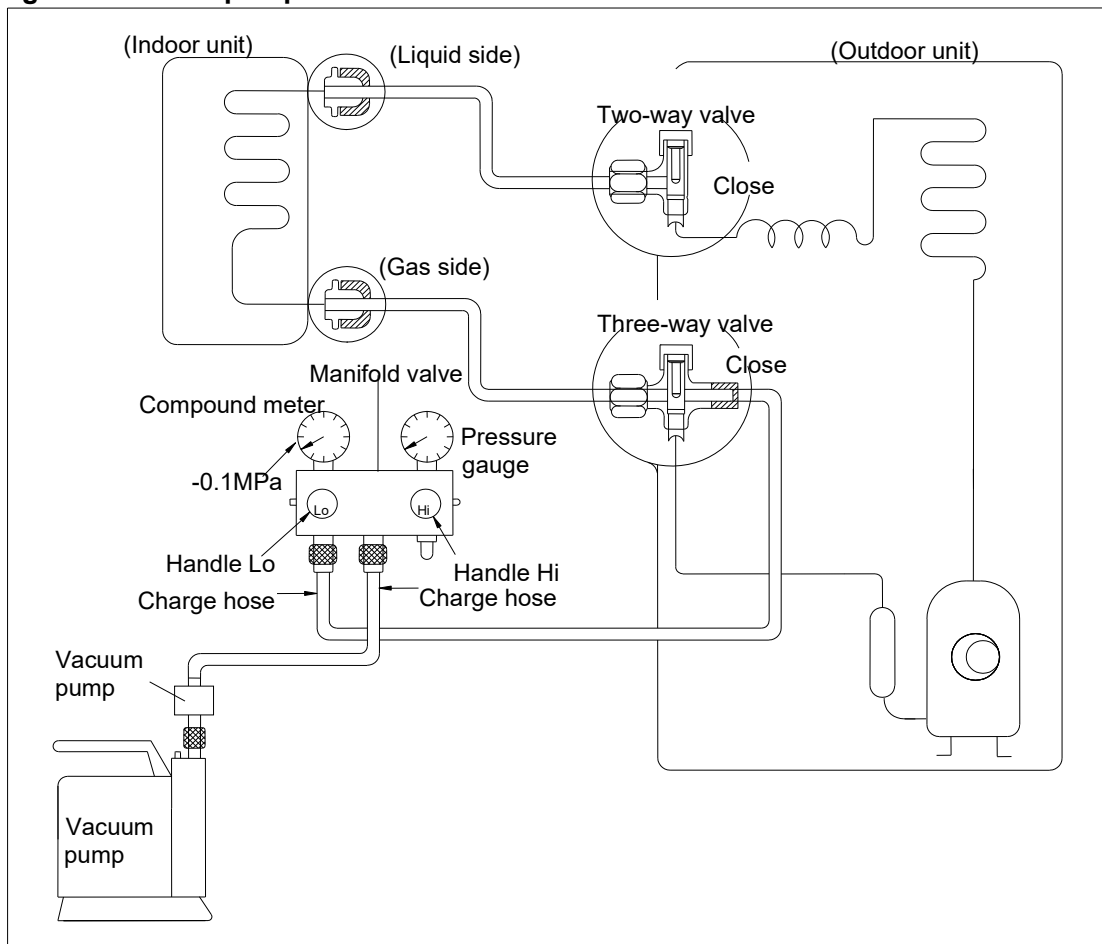

Procedure:

- 1) Completely tighten the flare nuts of the indoor and outdoor units, confirm that both the 2-way and 3-way valves are set to the closed position.
- 2) Connect the charge hose with the push pin of handle lo to the 3-way valves gas service port..
- 3) Connect the charge hose of handle hi connection to the vacuum pump.
- 4) Fully open the handle Lo of the manifold valve.
- 5) Operate the vacuum pump to evacuate.
- 6) Make evacuation for 30 minutes and check whether the compound meter indicates -0.1Mpa. If the meter does not indicate -0.1Mpa after pumping 30 minutes, it should be pumped 20 minutes more. If the pressure can't achieve -0.1Mpa after pumping 50 minutes, please check if there are some leakage points. Fully close the handle Lo valve of the manifold valve and stop the operation of the vacuum pump. Confirm that the gauge needle does not move (approximately 5 minutes after turning off the vacuum pump).
- 7) Turn the flare nut of the 3-way valves about 45° counterclockwise for 6 or 7seconds after the gas coming out, then tighten the flare nut again. Make sure the pressure display in the pressure indicator is a little higher than the atmosphere pressure. Then remove the charge hose from the 3 way valve.
- 8) Fully open the 2 way valve and 3 way valve and securely tighten the cap of the 3 way valve.

8.7 Re-installation while the outdoor unit need to be repaired

1. Evacuation for the whole system

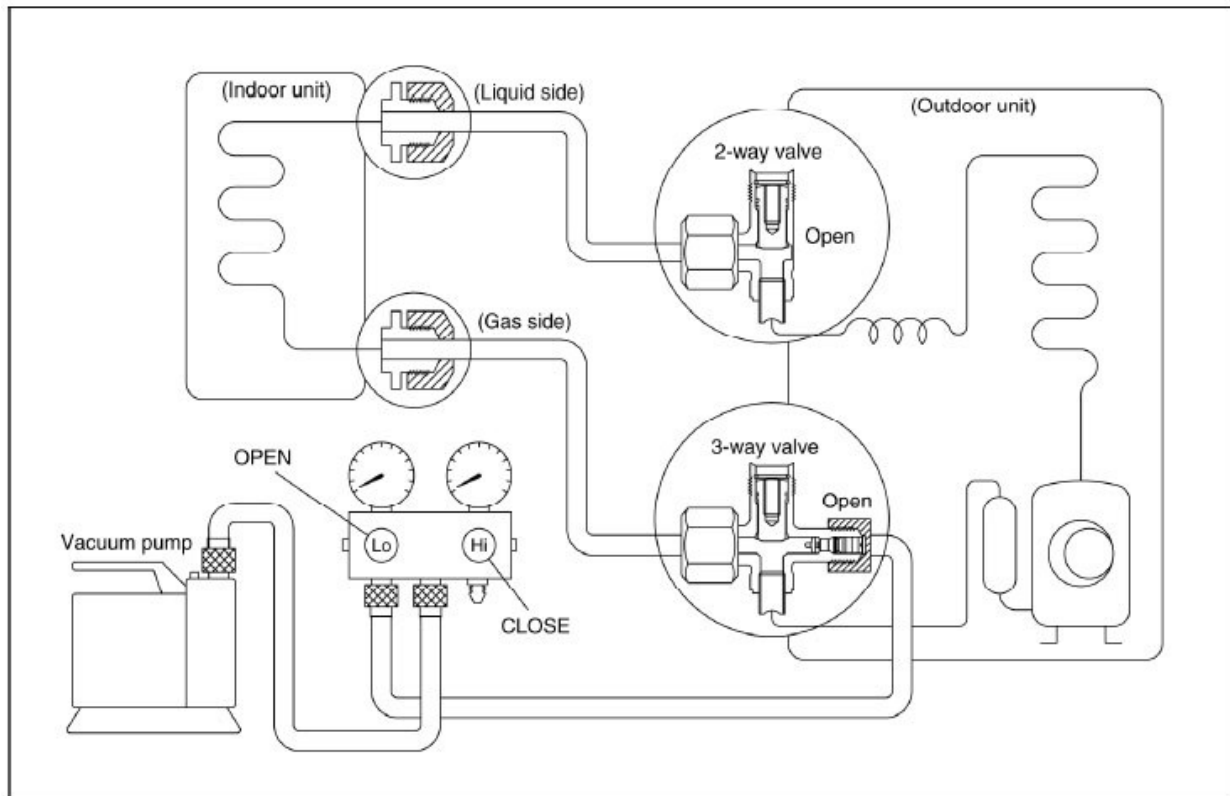

Procedure:

- 1). Confirm that both the 2-way and 3-way valves are set to the opened position.
- 2). Connect the vacuum pump to 3-way valve's service port.
- 3). Evacuation for approximately one hour. Confirm that the compound meter indicates -0.1Mpa .
- 4). Close the valve (Low side) on the charge set, turn off the vacuum pump, and confirm that the gauge needle does not move (approximately 5 minutes after turning off the vacuum pump).
- 5). Disconnect the charge hose from the vacuum pump.

2. Refrigerant charging

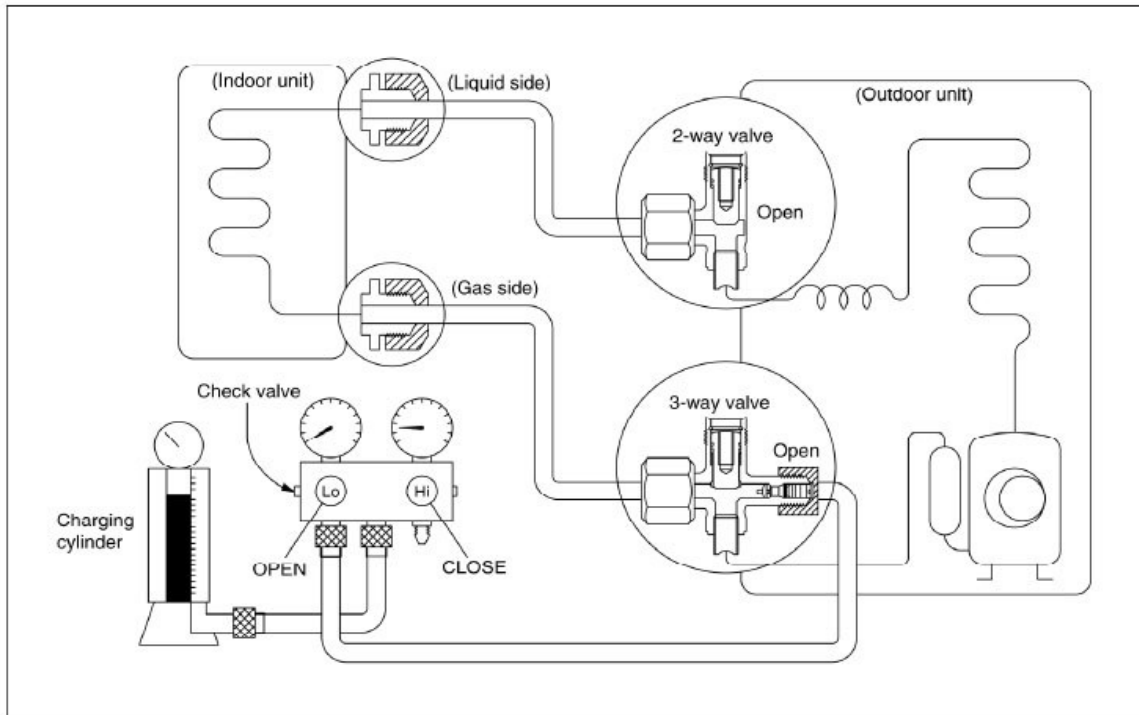

Procedure:

- 1). Connect the charge hose to the charging cylinder, open the 2-way valve and the 3-way valve
Connect the charge hose which you disconnected from the vacuum pump to the valve at the bottom of the cylinder. Make the cylinder bottom up to ensure liquid charge.
- 2). Purge the air from the charge hose
Open the valve at the bottom of the cylinder and press the check valve on the charge set to purge the air (be careful of the liquid refrigerant).
- 3) Put the charging cylinder onto the electronic scale and record the weight.
- 4). Open the valves (Low side) on the charge set and charge the system with liquid refrigerant
If the system cannot be charge with the specified amount of refrigerant, or can be charged with a little at a time (approximately 150g each time) , operating the air conditioner in the cooling cycle; however, one time is not sufficient, wait approximately 1 minute and then repeat the procedure.
- 5).When the electronic scale displays the proper weight, disconnect the charge hose from the 3-way valve's service port immediately
If the system has been charged with liquid refrigerant while operating the air conditioner, turn off the air conditioner before disconnecting the hose.
- 6). Mounted the valve stem caps and the service port
Use torque wrench to tighten the service port cap to a torque of 18N.m.
Be sure to check for gas leakage

9. Electronic control function

9.1 Abbreviation

T1: Indoor ambient temperature

T2: Coil temperature of indoor heat exchanger middle.

T2B: Coil temperature of indoor heat exchanger outlet(This sensor is located in outdoor unit)

T3: Coil temperature of outdoor heat exchanger

T4: Outdoor ambient temperature

TP: Compressor discharge temperature

Ts: Setting temperature

9.2 Electric control working environment.

9.2.1 Input voltage: 198V~264V.

9.2.2 Input power frequency:50Hz.

9.2.3 Indoor fan normal working amp. is less than 1A.

9.2.4 Outdoor fan. normal working amp. is less than 1.5A.

9.2.5 Four-way valve normal working amp. is less than 1A.

9.3 Outdoor unit's digital display tube

There is a digital display tube in outdoor PCB.

Digital display tube display function

- In standby , the LED displays “- -”
- In compressor operation, the LED display the running frequency,
- In defrosting mode, The LED displays “dF” or alternative displays between running frequency and “dF”(each displays 0.5s)
- In compressor pre-heating, The LED displays “PH” or alternative displays between running frequency and “PH”(each displays 0.5s)
- During the oil return process, The LED displays “RO” or alternative displays between running frequency and “RO”(each displays 0.5s)
- In low ambient cooling mode, the LED displays “LC” or alternative displays between running frequency and “LC”(each displays 0.5s)
- In forced cooling mode, the LED displays “FC” or alternative displays between running frequency and “FC”(each displays 0.5s)
- When PFC module protection occurs three times within 15 minutes, the LED displays “E6” or alternative displays between running frequency and “E6”(each displays 0.5s)
- In protection or malfunction, the LED displays error code or protection code.

“PH”, “RO”, “LC”, “E6” are not suitable for M5OE-42HFN8-Q.

9.4 Outdoor unit point check function

A check switch is included on the outdoor PCB.

Push SW1 to check the unit's status while running. The digital display shows the following codes each time the SW1 is pushed.

For M2OF-18HFN8-Q, M3OC-27HFN8-Q, M3OG-21HFN8-Q, M3OA-27HFN8-Q, M3OB-27HFN8-Q, M4OA-24HFN8-Q, M4OC-36HFN8-Q

Number of Presses	Display	Remark												
0	Normal display	Displays running frequency, running state, or malfunction code												
1	Quantity of indoor units with working connection	Actual data <table border="1" style="margin-left: 20px;"> <thead> <tr> <th>Display</th> <th>Number of indoor unit</th> </tr> </thead> <tbody> <tr> <td>1</td> <td>1</td> </tr> <tr> <td>2</td> <td>2</td> </tr> <tr> <td>3</td> <td>3</td> </tr> <tr> <td>4</td> <td>4</td> </tr> <tr> <td>5</td> <td>5</td> </tr> </tbody> </table>	Display	Number of indoor unit	1	1	2	2	3	3	4	4	5	5
Display	Number of indoor unit													
1	1													
2	2													
3	3													
4	4													
5	5													
2	Outdoor unit running mode code	Off: 0, Fan only: 1, Cooling: 2, Heating: 3, Forced cooling: 4. Forced defrost: A												
3	Indoor unit A capacity	The capacity unit is horse power. If the indoor unit is not connected, the digital display shows the following: "____" (9K:1HP,12K:1.2HP,18K:1.5HP,24K:2.0HP)												
4	Indoor unit B capacity													
5	Indoor unit C capacity													
6	Indoor unit D capacity													
7	Indoor unit E capacity													
8	Indoor unit A capacity demand code	Norm code*HP (9K: 1HP,12K: 1.2HP,18K: 1.5HP,24K:2.0HP)												
9	Indoor unit B capacity demand code													
10	Indoor unit C capacity demand code													
11	Indoor unit D capacity demand code													
12	Indoor unit E capacity demand code													
13	Outdoor unit amendatory capacity demand code													
14	The frequency corresponding to the total indoor units' amendatory capacity demand													
15	The frequency after the frequency limit													
16	The frequency sending to compressor control chip													
17	Indoor unit A evaporator outlet temperature (T _{2B} A)	If the temperature is lower than -9 °C, the digital display shows "-9." If the temperature is higher than 70 °C, the digital display shows "70." If the indoor unit is not connected, the digital display shows: "____"												
18	Indoor unit B evaporator outlet temperature (T _{2B} B)													
19	Indoor unit C evaporator outlet temperature (T _{2B} C)													
20	Indoor unit D evaporator outlet temperature (T _{2B} D)													
21	Indoor unit E evaporator outlet temperature (T _{2B} E)													
22	Indoor unit A room temperature (T ₁ A)	If the temperature is lower than 0 °C, the digital display shows "0." If the temperature is higher than 50 °C, the digital display shows "50." If the indoor unit is not connected, the digital display shows: "____"												
23	Indoor unit B room temperature (T ₁ B)													
24	Indoor unit C room temperature (T ₁ C)													
25	Indoor unit D room temperature (T ₁ D)													
26	Indoor unit E room temperature (T ₁ E)													
27	Indoor unit A evaporator temperature (T ₂ A)	If the temperature is lower than -9 °C, the digital display shows "-9." If the temperature is higher than 70 °C, the digital display shows "70." If the indoor unit is not connected, the digital display shows: "____"												
28	Indoor unit B evaporator temperature (T ₂ B)													
29	Indoor unit C evaporator temperature (T ₂ C)													
30	Indoor unit D evaporator temperature (T ₂ D)													

31	Indoor unit E evaporator temperature (T _{2E})			
32	Condenser pipe temperature (T ₃)			
33	Outdoor ambient temperature (T ₄)			
34	Compressor discharge temperature (TP)	The display value is between 30–129 °C. If the temperature is lower than 30 °C, the digital display shows “30.” If the temperature is higher than 99 °C, light the decimal point of the high digit tube. For example, if the display shows 0.5, so 0.5 multiplied by 10 to become 5, then added to 100 to become 105 °C.		
35	AD value of current	The display value is a hex number. For example, the digital display tube shows “Cd”, so $C*161+d*160=12*16+13=205$, it means AD value is 205. AD value is detected by the chip.		
36	AD value of AC voltage			
37	AD value of DC voltage			
38	EXV open angle for A indoor unit	Actual data/4. If the value is higher than 99, the digital display shows single and double digits. For example, if the digital display shows “2.0”, so 2.0 multiplied by 10 to become 20, then added to 100 to become 120, the EXV open angle is $120*4=480p$.		
39	EXV open angle for B indoor unit			
40	EXV open angle for C indoor unit			
41	EXV open angle for D indoor unit			
42	EXV open angle for E indoor unit			
43	MVI valve open angle			
44	EVI valve open angle			
45	Frequency limit symbol	Bit7	Reserve	The display value is a hexadecimal number. For example, the digital display show 2A, the corresponding binary is 101010, so Bit5=1, Bit3=1, and Bit1=1. This means that a frequency limit may be caused by current, IPM or T3.
Bit6		Frequency limit caused by voltage		
Bit5		Frequency limit caused by current.		
Bit4		Reserve.		
Bit3		Frequency limit caused by IPM.		
Bit2		Frequency limit caused by TP.		
Bit1		Frequency limit caused by T3		
Bit0		Frequency limit caused by T2		
46	T2B fault	00:No fault,01:T2B-A fault, ,02:T2B-B fault ,03:T2B-C fault,04:T2B-D fault, 05:T2B-E fault, 06:T2B-F fault(The display priority is A-B-C-D-E-F)		
47	Average value of T2	(Sum T2 value of all indoor units)/(number of indoor units in good connection)(The heating is the average value of T2, and the cooling is the average value of T2B)		
48	Outdoor unit fan motor state	Off: 0, Super ultra high speed:1, Super high speed:2, High speed:3, Med speed: 4, Low speed: 5, Breeze:6, Super breeze: 7		
49	Reason of stop			
50	Water inlet temperature of hydraulic module (TW_in)	If the temperature is lower than -9 °C, the digital display shows “-9.” If the temperature is higher than 70 °C, the digital display shows “70.” If machine A is not connected or is not ATW, the digital display shows: “——”(Only applicable to M3OB-27HFN8-Q, M4OC-36HFN8-Q)		
51	Water outlet temperature of heat exchanger (TW_out)			
52	Water outlet temperature of hydraulic module (TW1)			
53	Gas pipe temperature (TR_out)			
54	Liquid pipe temperature (TR_in)			
55	Water temperature of the water tank (TK)			
56	Backwater temperature of the water tank (TH)			
57	Total outlet temperature of hydraulic module system (after expansion tank) (TW1B)			
58	Setting temperature of exchanger outlet water (TW1S)	The display value is between 25–60 °C. If machine A is not connected or is not ATW, the digital display shows: “——”(Only applicable to M3OB-27HFN8-Q, M4OC-36HFN8-Q)		
59	Setting temperature of the water tank (TKs)	The display value is between 35–55 °C. If machine A is not connected or is not ATW, the digital display shows: “——”(Only applicable to M3OB-27HFN8-Q, M4OC-36HFN8-Q)		
60~63	Reserved			

64	Target discharge temperature	The display value is between 0–199°C. If the temperature is lower than 30°C, the digital display shows “30.” If the temperature is higher than 99°C, the digital display shows single and double digits. For example, If the display shows 0.5, so 0.5 multiplied by 10 to become 5, then added to 100 to become 105°C.. (Only applicable to M2OF-18HFN8-Q, M3OC-27HFN8-Q& M4OA-24HFN8-Q)
65~70	Reserved	
71	IPM module temperature	The display value is between 0–199°C. If the temperature is higher than 99°C, the digital display shows single and double digits. For example, If the display shows 5.0, so 5.0 multiplied by 10 to become 50, then added to 100 to become 150°C. (Only applicable to M2OF-18HFN8-Q, M3OC-27HFN8-Q& M4OA-24HFN8-Q)

For M4OB-36HFN8-Q

Number of Presses	Display	Remark										
0	Normal display	Displays running frequency, running state, or malfunction code										
1	Quantity of indoor units with working connection	Actual data <table border="1" style="margin-left: 20px;"> <thead> <tr> <th>Display</th> <th>Number of indoor unit</th> </tr> </thead> <tbody> <tr> <td>1</td> <td>1</td> </tr> <tr> <td>2</td> <td>2</td> </tr> <tr> <td>3</td> <td>3</td> </tr> <tr> <td>4</td> <td>4</td> </tr> </tbody> </table>	Display	Number of indoor unit	1	1	2	2	3	3	4	4
Display	Number of indoor unit											
1	1											
2	2											
3	3											
4	4											
2	Outdoor unit running mode code	Off: 0, Fan only: 1, Cooling: 2, Heating: 3, Forced cooling: 4. Forced defrosting :A, DHW:C, Heating and DHW: d										
3	Indoor unit A capacity	The capacity unit is horse power. If the indoor unit is not connected, the digital display shows the following: "____" (9K:1HP,12K:1.2HP,18K:1.5HP)										
4	Indoor unit B capacity											
5	Indoor unit C capacity											
6	Indoor unit D capacity											
7	Indoor unit E capacity											
8	Indoor unit A capacity demand code	Norm code*HP (9K: 1HP,12K: 1.2HP,18K: 1.5HP)										
9	Indoor unit B capacity demand code											
10	Indoor unit C capacity demand code											
11	Indoor unit D capacity demand code											
12	Indoor unit E capacity demand code											
13	Outdoor unit amendatory capacity demand code											
14	The frequency corresponding to the total indoor units' amendatory capacity demand											
15	The frequency after the frequency limit											
16	The frequency sending to compressor control chip											
17	Indoor unit A evaporator outlet temperature (T _{2B} A)	If the temperature is lower than -9 °C, the digital display shows "-9." If the temperature is higher than 70 °C, the digital display shows "70." If the indoor unit is not connected, the digital display shows: "____"										
18	Indoor unit B evaporator outlet temperature (T _{2B} B)											
19	Indoor unit C evaporator outlet temperature (T _{2B} C)											
20	Indoor unit D evaporator outlet temperature (T _{2B} D)											
21	Indoor unit E evaporator outlet temperature (T _{2B} E)											
22	Indoor unit A room temperature (T ₁ A)	If the temperature is lower than 0 °C, the digital display shows "0." If the temperature is higher than 50 °C, the digital display shows "50." If the indoor unit is not connected, the digital display shows: "____"										
23	Indoor unit B room temperature (T ₁ B)											
24	Indoor unit C room temperature (T ₁ C)											
25	Indoor unit D room temperature (T ₁ D)											
26	Indoor unit E room temperature (T ₁ E)											
27	Indoor unit A evaporator temperature (T ₂ A)	If the temperature is lower than -9 °C, the digital display shows "-9." If the temperature is higher than 70 °C, the digital display shows "70." If the indoor unit is not connected, the digital display shows: "____"										
28	Indoor unit B evaporator temperature (T ₂ B)											
29	Indoor unit C evaporator temperature (T ₂ C)											
30	Indoor unit D evaporator temperature (T ₂ D)											
31	Indoor unit E evaporator temperature (T ₂ E)											
32	Condenser pipe temperature (T ₃)											
33	Outdoor ambient temperature (T ₄)											
34	Compressor discharge temperature (TP)	The display value is between 30–129 °C. If the temperature is lower than 30 °C, the digital display shows "30." If the temperature is higher than 99 °C, the digital display shows single and double digits. For example, if the digital display shows "0.5", the compressor discharge temperature is 105 °C.										
35	AD value of current	The display value is a hex number.										

36	AD value of voltage	For example, the digital display tube shows "Cd", it means AD value is 205.		
37	EXV open angle for A indoor unit	Actual data/4. If the value is higher than 99, the digital display shows single and double digits. For example, if the digital display shows "2.0", the EXV open angle is 120×4=480p.		
38	EXV open angle for B indoor unit			
39	EXV open angle for C indoor unit			
40	EXV open angle for D indoor unit			
41	EXV open angle for E indoor unit			
42	Frequency limit symbol	Bit7	Frequency limit caused by IGBT radiator	The display value is a hexadecimal number. For example, the digital display show 2A, then Bit5=1, Bit3=1, and Bit1=1. This means that a frequency limit may be caused by T4, T3, or the current.
		Bit6	Frequency limit caused by PFC	
		Bit5	Frequency limit caused by T4.	
		Bit4	Frequency limit caused by T2.	
		Bit3	Frequency limit caused by T3.	
		Bit2	Frequency limit caused by TP.	
		Bit1	Frequency limit caused by current	
		Bit0	Frequency limit caused by voltage	
43	Average value of T2	(Sum T2 value of all indoor units)/(number of indoor units in good connection)		
44	Outdoor unit fan motor state	Off: 0, Super high speed:1, High speed:2, Med speed: 3, Low speed: 4, Breeze:5, Super breeze: 6		
45	The last error or protection code	00 means no malfunction and protection		
46	F indoor unit capacity			
47	F indoor unit capacity demand code			
48	F indoor unit evaporator outlet temperature (T _{2B} F)	If the temperature is lower than -9 °C, the digital display shows "-9." If the temperature is higher than 70 °C, the digital display shows "70." If the indoor unit is not connected, the digital display shows: "____"		
49	F indoor unit room temperature (T ₁ F)			
50	F indoor unit evaporator temperature (T ₂ F)			
51	EXV open angle for F indoor unit			
52	Type of machine A	1:ATW; 0:Air conditioner		
53	Water inlet temperature of heat exchanger (TW _{in})	If the temperature is lower than -9 °C, the digital display shows "-9." If the temperature is higher than 70 °C, the digital display shows "70." If the indoor unit is not connected, the digital display shows: "____"		
54	Water outlet temperature of heat exchanger (TW _{out})			
55	Water outlet temperature(TW1)			
56	Gas pipe temperature(TR _{out})			
57	Liquid pipe temperature(TR _{in})			
58	Water temperature of the water tank(Tk)			
59	Backwater temperature of the water Tank(TWH)			
60	Total outlet temperature of hydraulic module system (after expansion tank)(TW1B)			
61	Indoor unit status	Bit7	Reserve	The display value is a decimalism number. For example, the digital display show 07, then Bit2=1, Bit1=1, and Bit0=1.
		Bit6	Reserve	
		Bit5	Reserve	
		Bit4	Reserve	
		Bit3	Reserve	
		Bit2	Protection from falling off of water inlet and outlet temperature sensor	
		Bit1	Anti-freeze protection	
		Bit0	Water pump 1: On 0: Off	
62	Running mode of ATW	1: Machine A is a ATW, displaying the running mode sent by machine A 2: Machine A is not ATW, and it displays "--"		
63	Setting temperature after correct (TD)			

64	Setting temperature by controller(TS)	
65	Setting temperature after water tank (TksD)	Machine A is not ATW, and it displays "--"
66	Setting temperature(Tks)	Machine A is not ATW, and it displays "--"

M50E-42HFN8-Q

Number of Presses	Display	Remark										
0	Normal display	Displays running frequency, running state, or malfunction code										
1	Quantity of indoor units with working connection	Actual data <table border="1" style="margin-left: 20px;"> <thead> <tr> <th>Display</th> <th>Number of indoor unit</th> </tr> </thead> <tbody> <tr> <td>1</td> <td>1</td> </tr> <tr> <td>2</td> <td>2</td> </tr> <tr> <td>3</td> <td>3</td> </tr> <tr> <td>4</td> <td>4</td> </tr> </tbody> </table>	Display	Number of indoor unit	1	1	2	2	3	3	4	4
Display	Number of indoor unit											
1	1											
2	2											
3	3											
4	4											
2	Outdoor unit running mode code	Off: 0, Fan only: 1, Cooling: 2, Heating: 3, Forced cooling: 4. Forced defrosting :A										
3	Indoor unit A capacity	The capacity unit is horse power. If the indoor unit is not connected, the digital display shows the following: "____" (9K:1HP,12K:1.2HP,18K:1.5HP)										
4	Indoor unit B capacity											
5	Indoor unit C capacity											
6	Indoor unit D capacity											
7	Indoor unit E capacity											
8	Indoor unit A capacity demand code	Norm code*HP (9K: 1HP,12K: 1.2HP,18K: 1.5HP)										
9	Indoor unit B capacity demand code											
10	Indoor unit C capacity demand code											
11	Indoor unit D capacity demand code											
12	Indoor unit E capacity demand code											
13	Outdoor unit amendatory capacity demand code											
14	The frequency corresponding to the total indoor units' amendatory capacity demand											
15	The frequency after the frequency limit											
16	The frequency sending to compressor control chip											
17	Indoor unit A evaporator outlet temperature (T _{2B} A)	If the temperature is lower than -9 °C, the digital display shows "-9." If the temperature is higher than 70 °C, the digital display shows "70." If the indoor unit is not connected, the digital display shows: "____"										
18	Indoor unit B evaporator outlet temperature (T _{2B} B)											
19	Indoor unit C evaporator outlet temperature (T _{2B} C)											
20	Indoor unit D evaporator outlet temperature (T _{2B} D)											
21	Indoor unit E evaporator outlet temperature (T _{2B} E)											
22	Indoor unit A room temperature (T ₁ A)	If the temperature is lower than 0 °C, the digital display shows "0." If the temperature is higher than 50 °C, the digital display shows "50." If the indoor unit is not connected, the digital display shows: "____"										
23	Indoor unit B room temperature (T ₁ B)											
24	Indoor unit C room temperature (T ₁ C)											
25	Indoor unit D room temperature (T ₁ D)											
26	Indoor unit E room temperature (T ₁ E)											
27	Indoor unit A evaporator temperature (T ₂ A)	If the temperature is lower than -9 °C, the digital display shows "-9." If the temperature is higher than 70 °C, the digital display shows "70." If the indoor unit is not connected, the digital display shows: "____"										
28	Indoor unit B evaporator temperature (T ₂ B)											
29	Indoor unit C evaporator temperature (T ₂ C)											
30	Indoor unit D evaporator temperature (T ₂ D)											
31	Indoor unit E evaporator temperature (T ₂ E)											
32	Condenser pipe temperature (T3)											
33	Outdoor ambient temperature (T4)											
34	Compressor discharge temperature (TP)	The display value is between 30–129 °C. If the temperature is lower than 30 °C, the digital display shows "30." If the temperature is higher than 99 °C, the digital display shows single and double digits. For example, if the digital display shows "0.5", the compressor discharge temperature is 105 °C.										
35	AD value of current	The display value is a hex number.										

36	AD value of voltage	For example, the digital display tube shows "Cd", it means AD value is 205.		
37	EXV open angle for A indoor unit	Actual data/4. If the value is higher than 99, the digital display shows single and double digits. For example, if the digital display shows "2.0", the EXV open angle is 120×4=480p.		
38	EXV open angle for B indoor unit			
39	EXV open angle for C indoor unit			
40	EXV open angle for D indoor unit			
41	EXV open angle for E indoor unit			
42	Frequency limit symbol	Bit7	Frequency limit caused by IGBT radiator	The display value is a hexadecimal number. For example, the digital display show 2A, then Bit5=1, Bit3=1, and Bit1=1. This means that a frequency limit may be caused by T4, T3, or the current.
		Bit6	Frequency limit caused by PFC	
		Bit5	Frequency limit caused by T4.	
		Bit4	Frequency limit caused by T2.	
		Bit3	Frequency limit caused by T3.	
		Bit2	Frequency limit caused by TP.	
		Bit1	Frequency limit caused by current	
		Bit0	Frequency limit caused by voltage	
43	Average value of T2	(Sum T2 value of all indoor units)/(number of indoor units in good connection)		
44	Outdoor unit fan motor state	Off: 0, Super high speed:1, High speed:2, Med speed: 3, Low speed: 4, Breeze:5, Super breeze: 6		
45	The last error or protection code	00 means no malfunction and protection		
46	F indoor unit capacity			
47	F indoor unit capacity demand code			
48	F indoor unit evaporator outlet temperature (T _{2B} F)	If the temperature is lower than -9 °C, the digital display shows "-9." If the temperature is higher than 70 °C, the digital display shows "70." If the indoor unit is not connected, the digital display shows: "——"		
49	F indoor unit room temperature (T ₁ F)			
50	F indoor unit evaporator temperature (T ₂ F)			
51	EXV open angle for F indoor unit			
52	Reason for shutdown			
53	Type of machine A	1:ATW; 0:Air conditioner		
54	Water inlet temperature of heat exchanger (TW _{in})	If the temperature is lower than -9 °C, the digital display shows "-9." If the temperature is higher than 70 °C, the digital display shows "70." If the indoor unit is not connected, the digital display shows: "——"		
55	Water outlet temperature of heat exchanger (TW _{out})			
56	Water outlet temperature(TW1)			
57	Gas pipe temperature(TR _{out})			
58	Liquid pipe temperature(TR _{in})			
59	Water temperature of the water tank(Tk)			
60	Backwater temperature of the water Tank(TWH)			
61	Total outlet temperature of hydraulic module system (after expansion tank)(TW1B)			
62	Indoor unit status2	Bit7	Reserve	The display value is a decimalism number. For example, the digital display show 07, then Bit2=1, Bit1=1, and Bit0=1.
		Bit6	Reserve	
		Bit5	Reserve	
		Bit4	Reserve	
		Bit3	Reserve	
		Bit2	Protection from falling off of water inlet and outlet temperature sensor	
		Bit1	Anti-freeze protection	
		Bit0	Water pump 1: On 0: Off	
63	Running mode of ATW	1: Machine A is a ATW, displaying the running mode sent by machine A 2: Machine A is not ATW, and it displays "--"		

64	Setting temperature after correct (TD)	
65	Setting temperature by controller(TS)	
66	Setting temperature after water tank (TksD)	Machine A is not ATW, and it displays "--"
67	Setting temperature(Tks)	Machine A is not ATW, and it displays "--"
68	Target exhaust temperature	

M4OD-36HFN8-Q&M5OG-42HFN8-Q

Number of Presses	Display	Remark										
0	Normal display	Displays running frequency, running state, or malfunction code										
1	Quantity of indoor units with working connection	Actual data <table border="1" style="margin-left: 20px;"> <thead> <tr> <th>Display</th> <th>Number of indoor unit</th> </tr> </thead> <tbody> <tr> <td>1</td> <td>1</td> </tr> <tr> <td>2</td> <td>2</td> </tr> <tr> <td>3</td> <td>3</td> </tr> <tr> <td>4</td> <td>4</td> </tr> </tbody> </table>	Display	Number of indoor unit	1	1	2	2	3	3	4	4
Display	Number of indoor unit											
1	1											
2	2											
3	3											
4	4											
2	Outdoor unit running mode code	Standby: 0, Fan only: 1, Cooling/Drying: 2, Heating: 3, Forced cooling: 6, Forced defrosting: A; ATW:B; Cooling+ATW:C; Heating+ATW:D										
3	Indoor unit A capacity	The capacity unit is horse power. If the indoor unit is not connected, the digital display shows the following: "____" (9K:1HP,12K:1.2HP,18K:1.5HP)										
4	Indoor unit B capacity											
5	Indoor unit C capacity											
6	Indoor unit D capacity											
7	Indoor unit E capacity											
8	Indoor unit A capacity demand code	Norm code*HP (9K: 1HP,12K: 1.2HP,18K: 1.5HP)										
9	Indoor unit B capacity demand code											
10	Indoor unit C capacity demand code											
11	Indoor unit D capacity demand code											
12	Indoor unit E capacity demand code											
13	Outdoor unit amendatory capacity demand code											
14	The frequency corresponding to the total indoor units' amendatory capacity demand											
15	The frequency after the frequency limit											
16	The frequency sending to compressor control chip											
17	Indoor unit A evaporator outlet temperature (T _{2B} A)	If the temperature is lower than -9 °C, the digital display shows "-9." If the temperature is higher than 70 °C, the digital display shows "70." If the indoor unit is not connected, the digital display shows: "____"										
18	Indoor unit B evaporator outlet temperature (T _{2B} B)											
19	Indoor unit C evaporator outlet temperature (T _{2B} C)											
20	Indoor unit D evaporator outlet temperature (T _{2B} D)											
21	Indoor unit E evaporator outlet temperature (T _{2B} E)											
22	Indoor unit A room temperature (T ₁ A)	If the temperature is lower than 0 °C, the digital display shows "0." If the temperature is higher than 70 °C, the digital display shows "70." If the indoor unit is not connected, the digital display shows: "____"										
23	Indoor unit B room temperature (T ₁ B)											
24	Indoor unit C room temperature (T ₁ C)											
25	Indoor unit D room temperature (T ₁ D)											
26	Indoor unit E room temperature (T ₁ E)											
27	Indoor unit A evaporator temperature (T ₂ A)	If the temperature is lower than -9 °C, the digital display shows "-9." If the temperature is higher than 70 °C, the digital display shows "70." If the indoor unit is not connected, the digital display shows: "____"										
28	Indoor unit B evaporator temperature (T ₂ B)											
29	Indoor unit C evaporator temperature (T ₂ C)											
30	Indoor unit D evaporator temperature (T ₂ D)											
31	Indoor unit E evaporator temperature (T ₂ E)											
32	Condenser pipe temperature (T ₃)											
33	Outdoor ambient temperature (T ₄)											
34	Compressor discharge temperature (TP)	The display value is between 30–129 °C. If the temperature is lower than 30 °C, the digital display shows "30." If the temperature is higher than 99 °C, the digital display shows single and double digits. For example, If the display										

		shows 0.5, so 0.5 multiplied by 10 to become 5, then added to 100 to become 105°C		
35	AD value of current	The display value is a hex number.		
36	AD value of AC voltage	For example, the digital display tube shows "Cd", so $C*161+d*160=12*16+13=205$, it means AD value is 205. AD value is detected by the chip.		
37	AD value of DC voltage			
38	EXV open angle for A indoor unit	Actual data/4. If the value is higher than 99, the digital display shows single and double digits. For example, if the digital display shows "2.0", so 2.0 multiplied by 10 to become 20, then added to 100 to become 120, the EXV open angle is $120 \times 4 = 480$ p		
39	EXV open angle for B indoor unit			
40	EXV open angle for C indoor unit			
41	EXV open angle for D indoor unit			
42	EXV open angle for E indoor unit			
43	MVI open angle (for some models)			
44	EXI open angle (for some models)			
45	Frequency limit symbol	Bit7	Reserve	The display value is a hexadecimal number. For example, the digital display show 2A, the corresponding binary is 101010, so Bit5=1, Bit3=1, and Bit1=1. This means that a frequency limit may be caused by current, IPM or T3.
		Bit6	Frequency limit caused by voltage	
		Bit5	Frequency limit caused by current.	
		Bit4	Reserve.	
		Bit3	Frequency limit caused by IPM.	
		Bit2	Frequency limit caused by Compressor discharge temperature(T5)	
		Bit1	Frequency limit caused by Outdoor heat exchanger pipe temperature(T3)	
		Bit0	Frequency limit caused by Middle indoor heat exchanger coil temperature(T2)	
46	T2B fault	00:No fault,01:T2B-A fault, .02:T2B-B fault ,03:T2B-C fault,04:T2B-D fault, 05:T2B-E fault, 06:T2B-F fault(The display priority is A-B-C-D-E-F)		
47	Average value of T2	(Sum T2 value of all indoor units)/(number of indoor units in good connection)(The heating is the average value of T2, and the cooling is the average value of T2B) If the temperature is lower than -9°C, the digital display shows "-9".		
48	Outdoor unit fan speed	See next list		
49	Reason of stop			
50~59	Reserved			
60	Air injection enthalpy inlet temperature (for some models)	If the temperature is lower than -9°C, the digital display shows "-9". If the temperature is higher than 70°C, the digital display shows "70." If the indoor unit is not connected, the digital display shows: "____"		
61	Air injection enthalpy outlet temperature (for some models)			
62	Condenser coil middle temperature (for some models)			
63	Refrigerant tube inlet temperature (for some models)			
64	Target discharge temperature	The display value is between 0–199°C. If the temperature is lower than 30°C, the digital display shows "30." If the temperature is higher than 99°C, the digital display shows single and double digits. For example, If the display shows 0.5, so 0.5 multiplied by 10 to become 5, then added to 100 to become 105°C.		
65~70	Reserved			
71	IPM module temperature	The display value is between 0–199°C. If the temperature is higher than 99°C, the digital display shows single and double digits. For example, If the display shows 5.0, so 5.0 multiplied by 10 to become 50, then added to 100 to become 150°C.		
72	The high pressure sensor detects the pressure corresponding to the condensation temperature(Tc)	For heat recovery system: If the temperature is lower than 0°C, the digital display shows "0". If the temperature is higher than 67°C, the digital LED will		

		flash. For non-heat recovery system, the digital display shows: "--"
73	Water temperature(Tk)	The display value is between 0–99 °C. If the indoor unit D is not connected, the digital display shows: "----"
74	Setting water temperature(Tks)	

For other models,

Number of Presses	Display	Remark										
0	Normal display	Displays running frequency, running state, or malfunction code										
1	Quantity of indoor units with working connection	Actual data <table border="1" style="margin-left: 20px;"> <thead> <tr> <th>Display</th> <th>Number of indoor unit</th> </tr> </thead> <tbody> <tr> <td>1</td> <td>1</td> </tr> <tr> <td>2</td> <td>2</td> </tr> <tr> <td>3</td> <td>3</td> </tr> <tr> <td>4</td> <td>4</td> </tr> </tbody> </table>	Display	Number of indoor unit	1	1	2	2	3	3	4	4
Display	Number of indoor unit											
1	1											
2	2											
3	3											
4	4											
2	Outdoor unit running mode code	Off: 0, Fan only: 1, Cooling: 2, Heating: 3, Forced cooling: 4. Forced defrosting :A										
3	Indoor unit A capacity	The capacity unit is horse power. If the indoor unit is not connected, the digital display shows the following: "----" (9K:1HP,12K:1.2HP,18K:1.5HP)										
4	Indoor unit B capacity											
5	Indoor unit C capacity											
6	Indoor unit D capacity											
7	Indoor unit E capacity											
8	Indoor unit A capacity demand code	Norm code*HP (9K: 1HP,12K: 1.2HP,18K: 1.5HP)										
9	Indoor unit B capacity demand code											
10	Indoor unit C capacity demand code											
11	Indoor unit D capacity demand code											
12	Indoor unit E capacity demand code											
13	Outdoor unit amendatory capacity demand code											
14	The frequency corresponding to the total indoor units' amendatory capacity demand											
15	The frequency after the frequency limit											
16	The frequency sending to compressor control chip											
17	Indoor unit A evaporator outlet temperature (T _{2B} A)	If the temperature is lower than -9 °C, the digital display shows "-9." If the temperature is higher than 70 °C, the digital display shows "70." If the indoor unit is not connected, the digital display shows: "----"										
18	Indoor unit B evaporator outlet temperature (T _{2B} B)											
19	Indoor unit C evaporator outlet temperature (T _{2B} C)											
20	Indoor unit D evaporator outlet temperature (T _{2B} D)											
21	Indoor unit E evaporator outlet temperature (T _{2B} E)											
22	Indoor unit A room temperature (T ₁ A)	If the temperature is lower than 0 °C, the digital display shows "0." If the temperature is higher than 50 °C, the digital display shows "50." If the indoor unit is not connected, the digital display shows: "----"										
23	Indoor unit B room temperature (T ₁ B)											
24	Indoor unit C room temperature (T ₁ C)											
25	Indoor unit D room temperature (T ₁ D)											
26	Indoor unit E room temperature (T ₁ E)											
27	Indoor unit A evaporator temperature (T ₂ A)	If the temperature is lower than -9 °C, the digital display shows "-9." If the temperature is higher than 70 °C, the digital display shows "70." If the indoor unit is not connected, the digital display shows: "----"										
28	Indoor unit B evaporator temperature (T ₂ B)											
29	Indoor unit C evaporator temperature (T ₂ C)											
30	Indoor unit D evaporator temperature (T ₂ D)											
31	Indoor unit E evaporator temperature (T ₂ E)											

32	Condenser pipe temperature (T3)			
33	Outdoor ambient temperature (T4)			
34	Compressor discharge temperature (TP)	The display value is between 30–129 °C. If the temperature is lower than 30 °C, the digital display shows "30." If the temperature is higher than 99 °C, the digital display shows single and double digits. For example, if the digital display shows "0.5", the compressor discharge temperature is 105 °C.		
35	AD value of current	The display value is a hex number. For example, the digital display tube shows "Cd", it means AD value is 205.		
36	AD value of voltage			
37	EXV open angle for A indoor unit	Actual data/4. If the value is higher than 99, the digital display shows single and double digits. For example, if the digital display shows "2.0", the EXV open angle is 120×4=480p.		
38	EXV open angle for B indoor unit			
39	EXV open angle for C indoor unit			
40	EXV open angle for D indoor unit			
41	EXV open angle for E indoor unit			
42	Frequency limit symbol	Bit7	Frequency limit caused by IGBT radiator	The display value is a hexadecimal number. For example, the digital display show 2A, then Bit5=1, Bit3=1, and Bit1=1. This means that a frequency limit may be caused by T4, T3, or the current.
		Bit6	Frequency limit caused by PFC	
		Bit5	Frequency limit caused by T4.	
		Bit4	Frequency limit caused by T2.	
		Bit3	Frequency limit caused by T3.	
		Bit2	Frequency limit caused by TP.	
		Bit1	Frequency limit caused by current	
		Bit0	Frequency limit caused by voltage	
43	Average value of T2	(Sum T2 value of all indoor units)/(number of indoor units in good connection)		
44	Outdoor unit fan motor state	Off: 0, Super high speed:1, High speed:2, Med speed: 3, Low speed: 4, Breeze:5, Super breeze: 6		
45	The last error or protection code	00 means no malfunction and protection		
46	F indoor unit capacity			
47	F indoor unit capacity demand code			
48	F indoor unit evaporator outlet temperature (T _{2B} F)	If the temperature is lower than -9 °C, the digital display shows "-9." If the temperature is higher than 70 °C, the digital display shows "70." If the indoor unit is not connected, the digital display shows: "—"		
49	F indoor unit room temperature (T ₁ F)			
50	F indoor unit evaporator temperature (T ₂ F)			
51	EXV open angle for F indoor unit			
52	Reason for shutdown(for some models)	Only applicable to M2OG-14HFN8-Q, M2OD-18HFN8-Q, M2OH-14HFN8-Q, M2OE-18HFN8-Q, M3OA-18HFN8-Q, M3OF-21HFN8-Q, M3OF-27HFN8-Q, M4OE-28HFN8-Q		

9.5 Protection

9.5.1 Three minutes delay at restart for compressor.

9.5.2 Sensor redundancy and automatic shutoff

If one temperature sensor(T3, T4, T2B or TP) malfunctions, the unit ceases operation and displays the corresponding error code.

9.5.3 Automatic shutoff based on fan

If the outdoor fan speed is operating outside of the normal range, fan lack of phase or fan zero speed failure, the unit ceases operation.

9.5.4 Inverter module protection

The inverter module has an automatic shutoff mechanism based on the unit's current and temperature. If automatic shutoff is initiated, the corresponding error code is displayed and the unit ceases operation.

9.5.5 Indoor/Outdoor Units Communication Protection

If the indoor units do not receive the feedback signal from the outdoor units for 2 consecutive minutes or the outdoor units do not receive the feedback signal from any one of indoor units for 3 consecutive minutes, the unit ceases operation. The unit displays the failure code.

9.5.6 EEPROM parameter error

If main chip does not receive feedback from EEPROM chip or parameter check error, the unit ceases operation.

9.5.7 Automatic shutoff based on compressor

If the compressor speed has been out of control, compressor lack of phase or voltage too low failure, the unit ceases operation.

9.5.8 Temperature Protection of Compressor Discharge

When the discharge temperature of the compressor rises, the running frequency is limited. If discharge temperature is too high, the compressor stops and then restart until discharge temperature reduced to normal range.

9.5.9 Evaporator Anti-Freezing Protection

The T2 sent from the indoor unit to the outdoor unit is low, and the unit limits the compressor to run at a low frequency.

9.5.10 Oil Return

- 1) If the unit runs at low frequency for a long time, the unit will run the oil return program to increase the frequency of the compressor;
- 2) After the unit runs continuously for a period of time, the unit will run the oil return program to increase the compressor frequency;
- 3) Through the setting of the engineering mode of the water tank, the oil can be returned according to the user's needs to avoid a certain period of time, so as to prevent the noise that may be generated by the oil return from affecting the user.

10. Troubleshooting

10.1 Indoor unit error code explanation:

For Aurora type ,All Easy type, Forest type, Four-way cassette type (compact), A6 Duct(MTIU-07HWFNX-QRD0W, MTIU-09HWFNX-QRD0W, MTIU-12HWFNX-QRD0W, MTIU-18HWFN1-QRD0W):

Malfunction	Error Code	Timer Lamp	Operation Lamp (flashes)
Indoor EEPROM malfunction	E0	X	1
Communication malfunction between indoor and outdoor units	E1	X	2
Indoor fan speed has been out of control	E3	X	4
Open or short circuit of T1 temperature sensor	E4	X	5
Open or short circuit of T2 temperature sensor	E5	X	6
Refrigerant leakage detection	EC	X	7
Water level alarm	EE	X	8
Overcurrent protection (For some units)	F0	O	1
Open or short circuit of T4 temperature sensor	F1	O	2
Open or short circuit of T3 temperature sensor	F2	O	3
Open or short circuit of TP temperature sensor	F3	O	4
Outdoor EEPROM malfunction (For some units)	F4	O	5
Outdoor fan speed is out of control	F5	O	6
Open or short circuit of T2B temperature sensor	F6	O	7
Communication malfunction between indoor two chips(For A6 Duct)	FA	O	11
IPM module malfunction	P0	☆	1
Over voltage or over low voltage protection	P1	☆	2
Low ambient temperature protection	P3	☆	4
Inverter compressor drive protection	P4	☆	5
Indoor units mode conflict	--	☆	6
Low pressure protection of compressor	P6	☆	7
O (on) X(off) ☆(flash at 2Hz)			

For Mission2 type and Ultimate Comfort type:

Malfunction	Error Code
Indoor EEPROM parameter error	E0/EA
Indoor / outdoor units communication error	E1
Indoor fan speed is operating outside of the normal range	E3
Indoor room temperature sensor T1 open circuit or short circuit	E4
Evaporator coil temperature sensor T2 open circuit or short circuit	E5
Communication error between the indoor PCB and display board	Eb/EH0b
Refrigerant leakage detection	EC
Overload current protection	F0
Outdoor ambient temperature sensor T4 open circuit or short circuit	F1
Condenser coil temperature sensor T3 open circuit or short circuit	F2
Compressor discharge temperature sensor TP open circuit or short circuit	F3
Outdoor EEPROM parameter error	F4
Outdoor fan speed is operating outside of the normal range	F5
IPM malfunction or IGBT over-strong current protection	P0
Over or low voltage protection	P1
High temperature protection of IPM module	P2
Low ambient temperature protection	P3
Inverter compressor drive error	P4
Indoor units mode conflict	--

For Xtreme type, Infini type, All Easy Pro type, GAIA type, XT type, BREEZELESS E type, GLORY PRO type:

Running Lamp	Timer Lamp	Display	Error Information
1 time	OFF	EH00/EH0A	Indoor EEPROM parameter error
2 times	OFF	EL01	Indoor/outdoor unit communication error
3 times	OFF	EH02	Zero-crossing signal detection error
4 times	OFF	EH03	The indoor fan speed is operating outside of the normal range
5 times	OFF	EC51	Outdoor EEPROM parameter error
5 times	OFF	EC52	Condenser coil temperature sensor T3 is in open circuit or has short circuited
5 times	OFF	EC53	Outdoor room temperature sensor T4 is in open circuit or has short circuited
5 times	OFF	EC54	Compressor discharge temperature sensor TP is in open circuit or has short circuited
5 times	OFF	EC56	Evaporator coil outlet temperature sensor T2B is in open circuit or has short circuited(for free-match indoor units)

6 times	OFF	EH60	Indoor room temperature sensor T1 is in open circuit or has short circuited
6 times	OFF	EH61	Evaporator coil middle temperature sensor T2 is in open circuit or has short circuited
12 times	OFF	EC07	The outdoor fan speed is operating outside of the normal range
9 times	OFF	EH0b	Indoor PCB/Display board communication error
8 times	OFF	EL0C	Refrigerant leakage detection
7 times	FLASH	PC00	IPM malfunction or IGBT over-strong current protection
2 times	FLASH	PC01	Over voltage or over low voltage protection
3 times	FLASH	PC02	Top temperature protection of compressor or High temperature protection of IPM module or High pressure protection
5 times	FLASH	PC04	Inverter compressor drive error
1 time	FLASH	PC08	Current overload protection
7 times	FLASH	PC03	High pressure protection or low pressure protection
4 times	FLASH	PC0L	Low ambient temperature protection
1 time	ON	--	Indoor units mode conflict
--	--	EHbA	Communication malfunction between fresh air motor module and indoor unit(Only for GAIA type)
4 times	OFF	EH3A	Fresh air motor DC bus voltage is too low protection(Only for GAIA type)
4 times	OFF	EH3b	Fresh air motor DC bus voltage is too high fault(Only for GAIA type)
4 times	OFF	EH3C	Fresh air motor malfunction(Only for GAIA type)
6 times	OFF	EH62	Fresh air temperature sensor TO is in open circuit or has short circuited(Only for GAIA type)

New 4-way cassette type, New console type, Compact cassette type, New compact cassette type, A6 duct type(MTIU-18HWFNX-QRD0W, MTIU-12HWFNX-QRD0W(GA), MTIU-18HWFNX-QRD0W(GA), MTI-24HWFNX-QRD0W(GA)), A7 duct type, One-way cassette type:

Running Lamp	Timer Lamp	Display	Error Information
1 time	OFF	EH00/EH0A	Indoor EEPROM parameter error
2 times	OFF	EL01	Indoor/outdoor unit communication error
3 times	OFF	EH02	Zero-crossing signal detection error
4 times	OFF	EH03	The indoor fan speed is operating outside of the normal range
5 times	OFF	EC51	Outdoor EEPROM parameter error
5 times	OFF	EC52	Condenser coil temperature sensor T3 is in open circuit or has short circuited
5 times	OFF	EC53	Outdoor room temperature sensor T4 is in open circuit or has short circuited
5 times	OFF	EC54	Compressor discharge temperature sensor TP is in open circuit or has short circuited
5 times	OFF	EC55	IGBT temperature sensor TH is in open circuit or has short circuited
5 times	OFF	EC56	Evaporator coil outlet temperature sensor T2B is in open circuit or has short circuited(for free-match indoor units)
6 times	OFF	EH60	Indoor room temperature sensor T1 is in open circuit or has short circuited
6 times	OFF	EH61	Evaporator coil middle temperature sensor T2 is in open circuit or has short circuited
12 times	OFF	EC07	The outdoor fan speed is operating outside of the normal range
9 times	OFF	EH0b	Communication error between indoor two chips(For A6 Duct)
9 times	OFF	EH0b	Communication error between display board and main board(for new console type)
13 times	OFF	EH0E	Water-level alarm malfunction
8 times	OFF	EL0C	Refrigerant leakage detection
7 times	FLASH	PC00	IPM malfunction or IGBT over-strong current protection
2 times	FLASH	PC01	Over voltage or over low voltage protection
3 times	FLASH	PC02	Top temperature protection of compressor or High temperature protection of IPM module or High pressure protection
5 times	FLASH	PC04	Inverter compressor drive error
1 time	FLASH	PC08	Current overload protection
7 times	FLASH	PC03	High pressure protection or low pressure protection
--	--	EHbA	Communication malfunction between external fan module and indoor unit
4 times	OFF	EH3A	External fan DC bus voltage is too low protection

4 times	OFF	EH3b	External fan DC bus voltage is too high fault
4 times	OFF	EH31	Upper indoor fan speed is operating outside of the normal range(for new console type)
4 times	OFF	EH32	Lower indoor fan speed is operating outside of the normal range(for new console type)
4 times	FLASH	PC0L	Low ambient temperature protection
1 time	ON	--	Indoor units mode conflict

10.2 Outdoor unit error code explanation:

For M2OF-18HFN8-Q, M3OC-27HFN8-Q, M3OA-18HFN8-Q, M3OG-21HFN8-Q, M3OA-27HFN8-Q, M4OA-24HFN8-Q, M3OB-27HFN8-Q, M4OC-36HFN8-Q& M5OE-42HFN8-Q

Display	LED STATUS
EC51	Outdoor EEPROM malfunction
EL01	Indoor / outdoor units communication error
PC40	Communication malfunction between IPM board and outdoor main board
PC08	Outdoor overcurrent protection
PC10	Outdoor unit low AC voltage protection
PC11	Outdoor unit main control board DC bus high voltage protection
PC12	Outdoor unit main control board DC bus high voltage protection /341 MCE error
PC00	IPM module protection
PC0F	PFC module protection
EC71	Over current failure of outdoor DC fan motor
EC72	Lack phase failure of outdoor DC fan motor
EC07	Outdoor fan speed has been out of control
PC43	Outdoor compressor lack phase protection
PC44	Outdoor unit zero speed protection
PC45	Outdoor unit IR chip drive failure
PC46	Compressor speed has been out of control
PC49	Compressor overcurrent failure
PC30	High pressure protection (For M3OB-27HFN8-Q, M4OA-24HFN8-Q, M3OC-27HFN8-Q& M5OE-42HFN8-Q)
PC31	Low pressure protection (For M3OB-27HFN8-Q, M3OC-27HFN8-Q& M5OE-42HFN8-Q)
PC0A	High temperature protection of condenser
PC06	Temperature protection of compressor discharge
PC0L	Low ambient temperature protection
PC02	Top temperature protection of compressor
EC52	Condenser coil temperature sensor T3 is in open circuit or has short circuited
EC53	Outdoor room temperature sensor T4 is in open circuit or has short circuited

EC54	Compressor discharge temperature sensor TP is in open circuit or has short circuited
EC56	Evaporator coil outlet temperature sensor T2B is in open circuit or has short circuited
EC50	Open or short circuit of outdoor unit temperature sensor(T3,T4.TP)
PC65	TR_in high temperature protection(ATW)
PC61	TW_out high temperature protection(ATW)
PC64	Defrosting water temperature too low protection(ATW)
LC12	The large difference between TW-in and TW-out limit frequency(ATW)
LC13	TR_in high temperature limit frequency(ATW)
LC14	TW_out temperature rising too fast limit frequency(ATW)

For other models,

Display	LED STATUS
E0	Outdoor EEPROM malfunction
E2	Indoor / outdoor units communication error
E3	Communication malfunction between IPM board and outdoor main board
E4	Open or short circuit of outdoor unit temperature sensor(T3,T4.TP)
E5	Voltage protection
E6	PFC module protection
E8	Outdoor fan speed has been out of control or compressor speed has been out of control
F1	No A Indoor unit coil outlet temperature sensor or connector of sensor is defective
F2	No B Indoor unit coil outlet temperature sensor or connector of sensor is defective
F3	No C Indoor unit coil outlet temperature sensor or connector of sensor is defective
F4	No D Indoor unit coil outlet temperature sensor or connector of sensor is defective
F5	No E Indoor unit coil outlet temperature sensor or connector of sensor is defective
P0	Top temperature protection of compressor
P1	High pressure protection (For M4OB-36HFN8-Q, M5OD-42HFN8-Q)
P2	Low pressure protection (For M4OB-36HFN8-Q, M5OD-42HFN8-Q)
P3	Current protection of compressor
P4	Temperature protection of compressor discharge
P5	High temperature protection of condenser
P6	IPM module protection
E9	24k indoor unit wiring error

LP	Low ambient temperature protection
----	------------------------------------

Note: Once these error codes display, they will disappear in at least 30 seconds if the unit come back to normal.(Except E2&E3)

10.3 Trouble shooting

10.3.1 For the indoor unit

10.3.1.1 Indoor EEPROM malfunction (IDU E0/EA/EH00/EH0A)

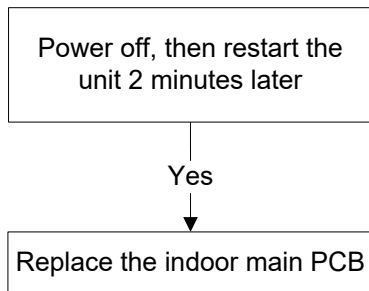

EEPROM: An electrically erasable programmable read-only memory whose contents can be erased and reprogrammed using a pulsed voltage.

10.3.1.2 Indoor / outdoor units communication error(E1(IDU)/ E2(ODU)/ EL01(IDU/ODU))

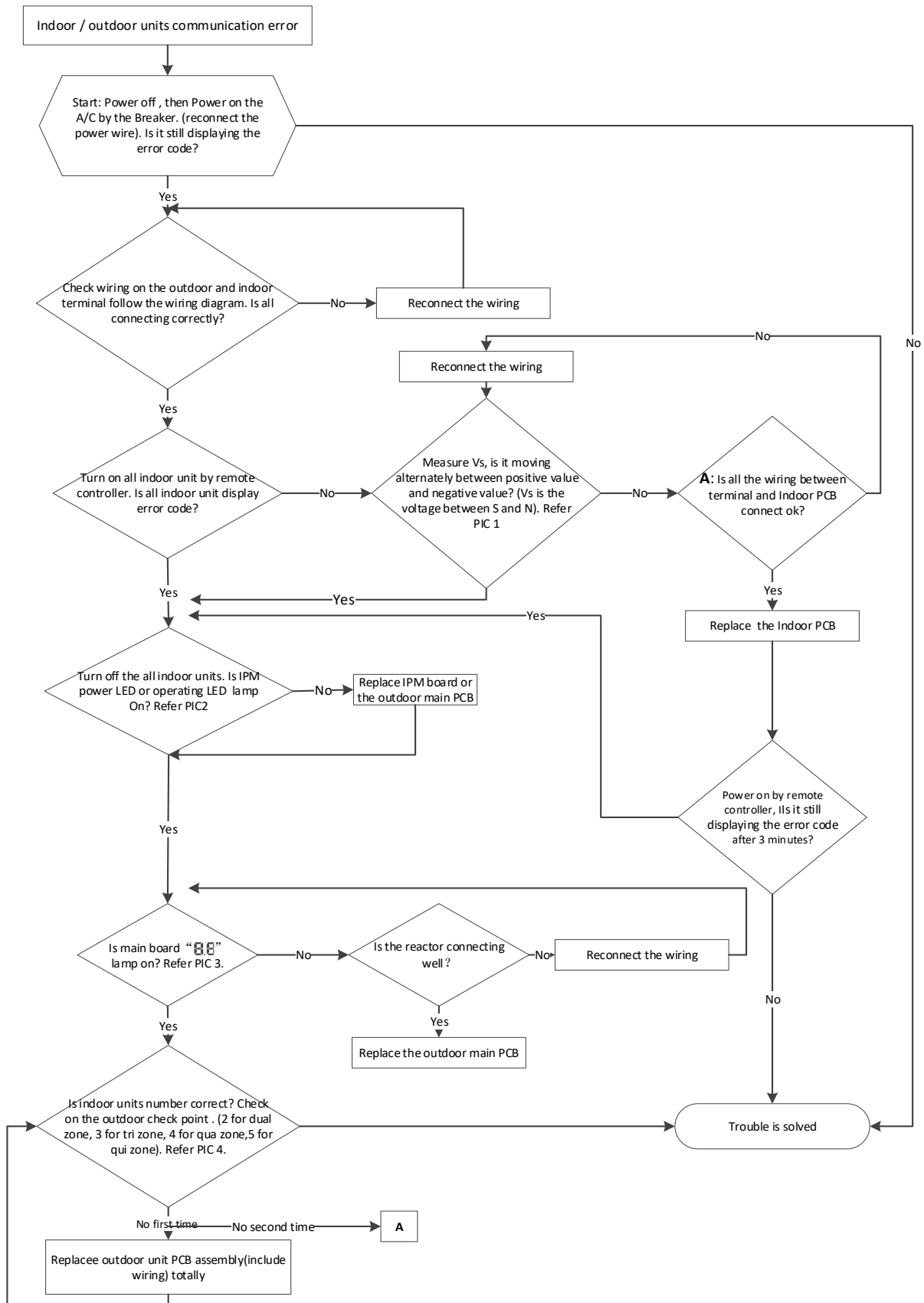



PiC1: check the voltage of N to S (Vs), is it moving alternately between positive value and negative value?



B

Pic 2: IPM or outdoor main PCB



Power,
Self-Check
Operating

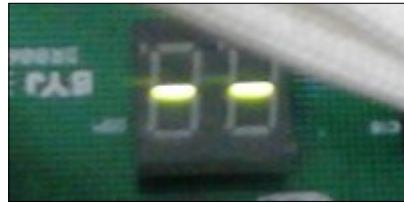

PIC3 :Main board LED when power on and unit standby.



PIC4: check point button,
Press 1 time for check how many indoor units are connected

10.3.1.3 Indoor fan speed has been out of control (IDU E3/ EH03)

Upper indoor fan speed is operating outside of the normal range(EH31)(for new console type)

Lower indoor fan speed is operating outside of the normal range(EH32) (for new console type)

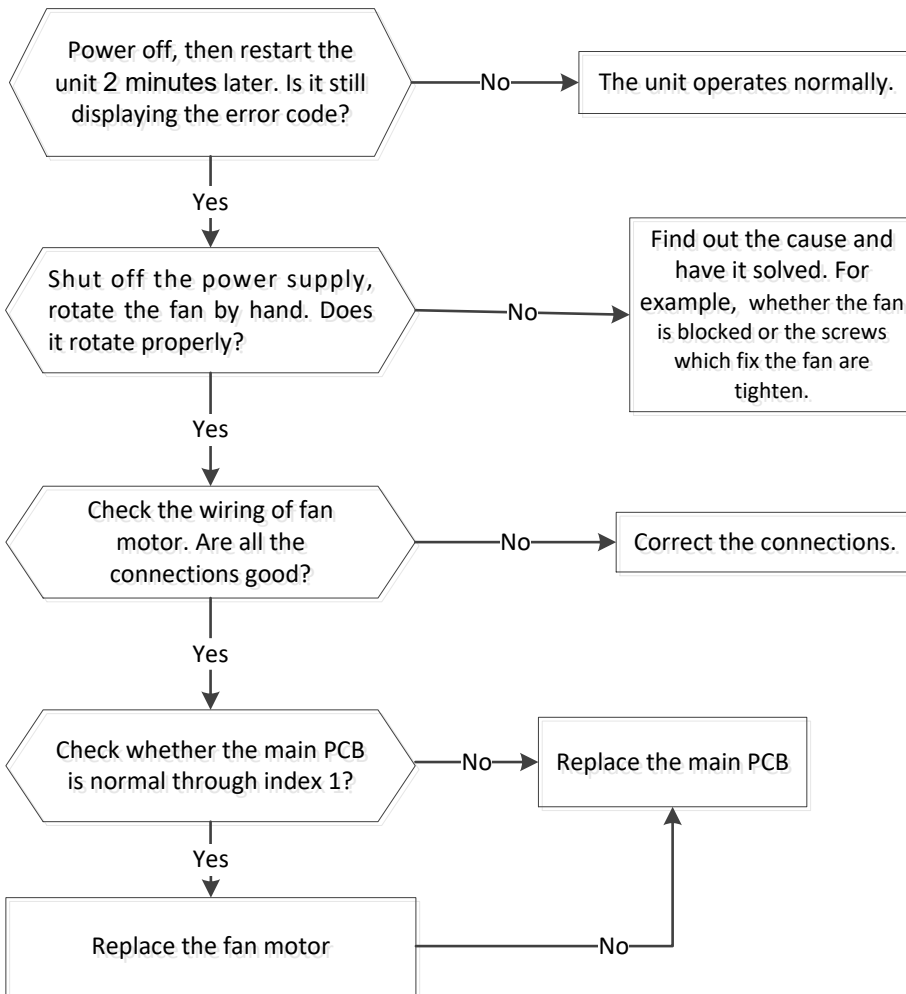

Index 1:

1: Indoor AC fan motor

Power on and set the unit running in fan mode at high fan speed. After running for 15 seconds, measure the voltage of pin1 and pin2. If the value of the voltage is less than 100V(208~240V power supply) or 50V(115V power supply), the PCB must have problems and need to be replaced.

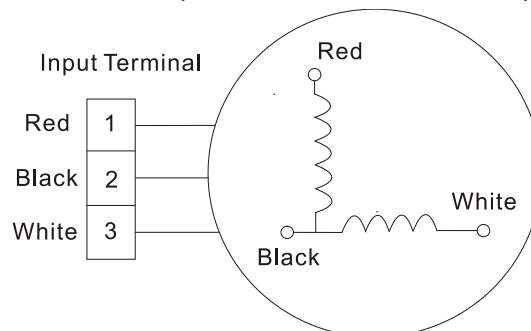

2. Indoor DC fan motor(control chip is inside fan motor)

Power on and when the unit is in standby, measure the voltage of pin1-pin3, pin4-pin3 in fan motor connector. If the value of the voltage is not in the range showing in below table, the PCB must have problems and need to be replaced.

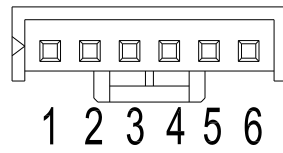
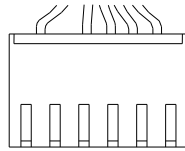

DC motor voltage input and output

For split type:

NO.	Color	Signal	Voltage
1	Red	Vs/Vm	280V~380V
2	---	---	---
3	Black	GND	0V
4	White	Vcc	14-17.5V
5	Yellow	Vsp	0~5.6V
6	Blue	FG	14-17.5V

For other types:

NO.	Color	Signal	Voltage
1	Red	Vs/Vm	192V~380V
2	---	---	---
3	Black	GND	0V
4	White	Vcc	13.5-16.5V
5	Yellow	Vsp	0~6.5V
6	Blue	FG	13.5-16.5V

3. Indoor DC Fan IPM Board (Duct Unit)

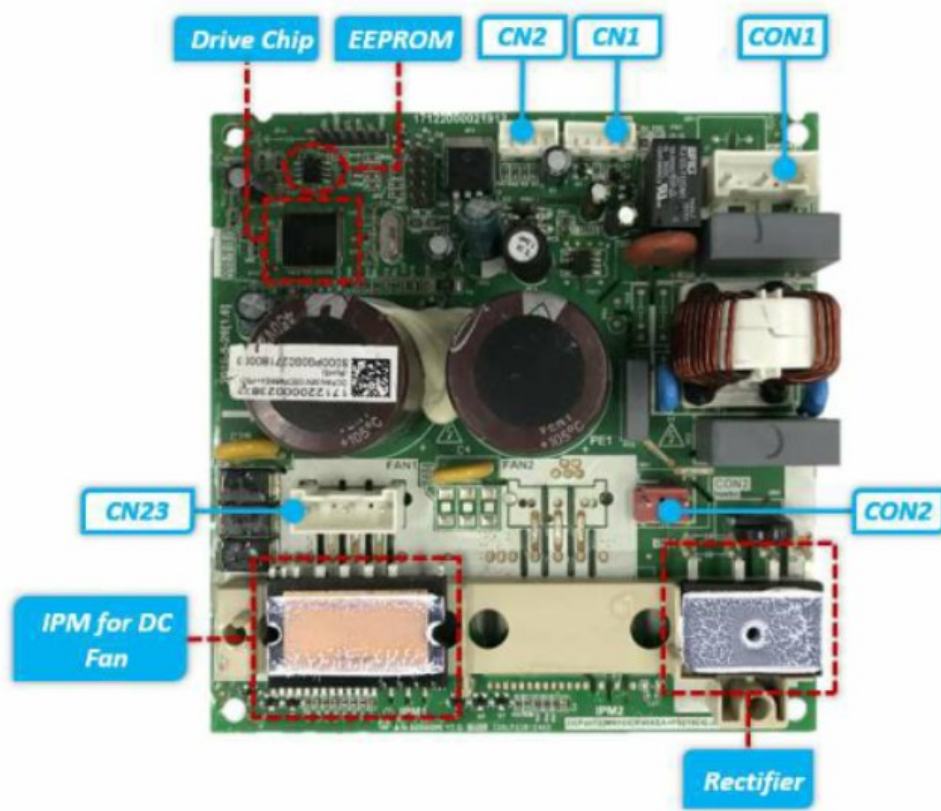

Port	Description	Parameter	Remark
CON1	Power input for the PCB	230V/AC	
CN1	Communication with main PCB	DC	
CN2	Test port	5V/DC	For debugging board
CN23	UVW output for DC fan motor		
CON2	Ports for reactor		

CN1 Communication with main PCB

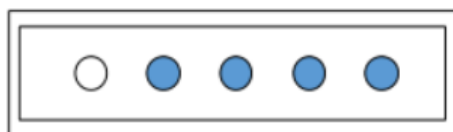

NO.	Signal	Voltage
1	Vcc	+15V
2	GND	
3	TXD	0~6V
4	RXD	0~15V
5	--	--

10.3.1.4 Open or short circuit of temperature sensor(IDU E4/E5/EH60/EH61)

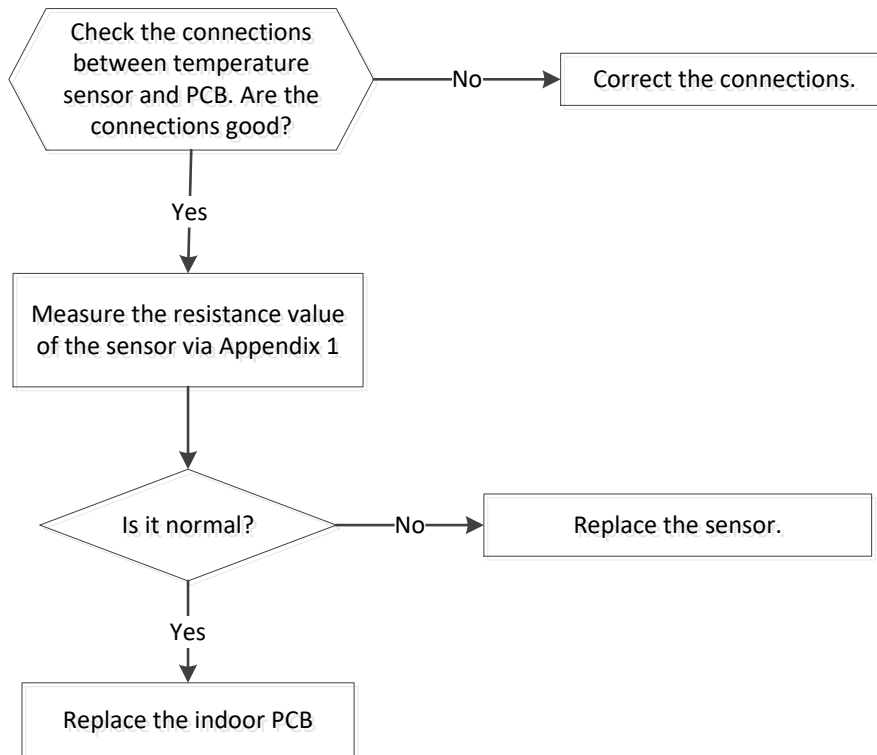

10.3.1.5 Water-level alarm malfunction(IDU EE)

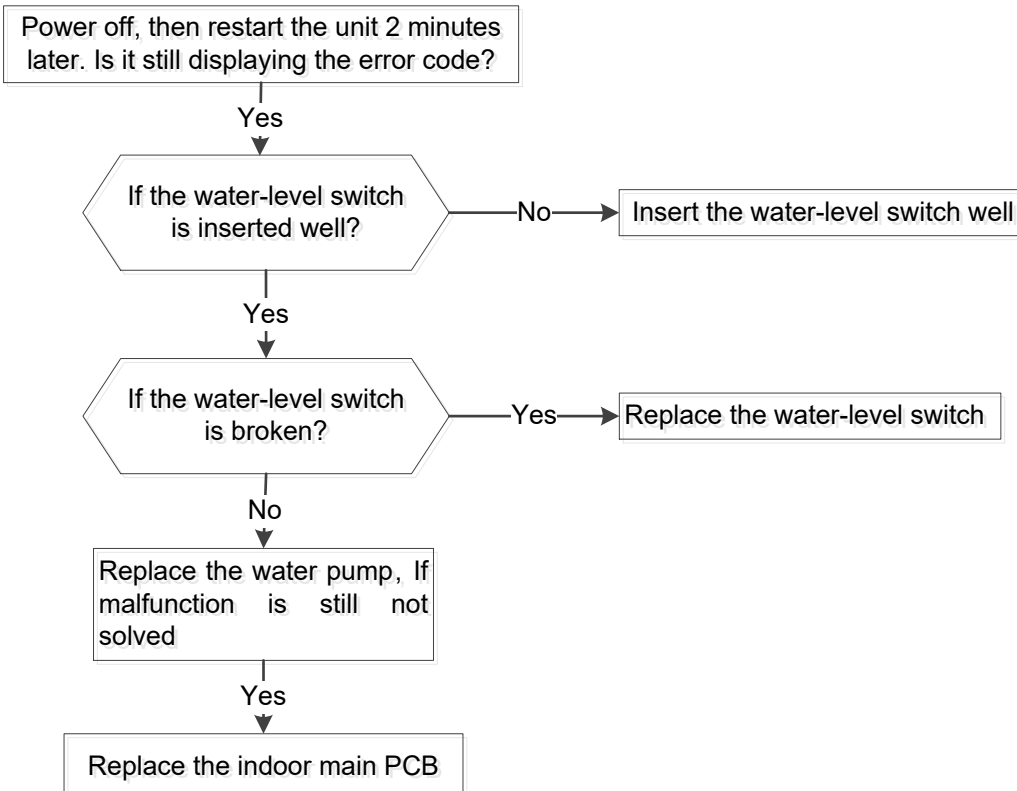

10.3.1.7 Communication error between the indoor PCB and display board(IDU Eb/EH0b)

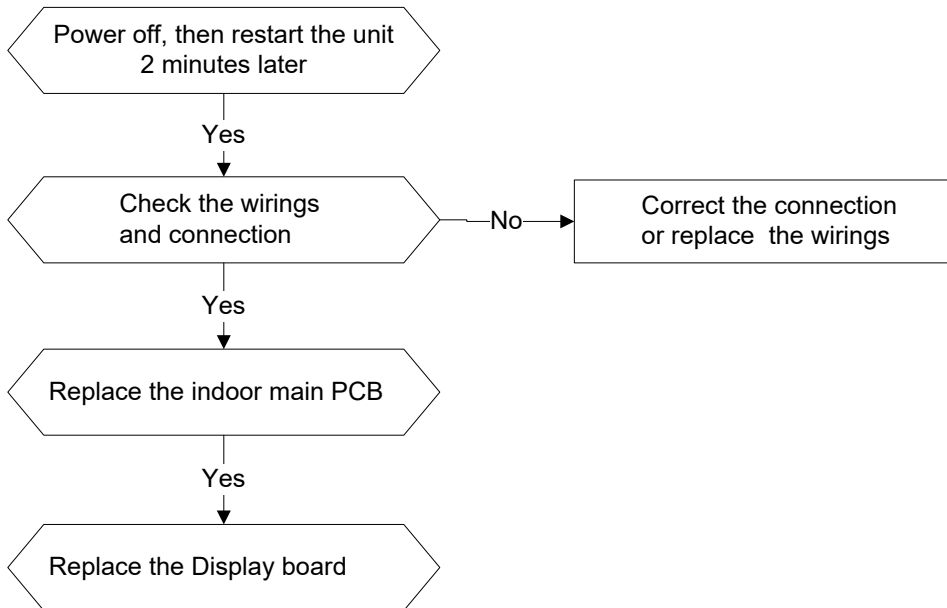

10.3.1.8 Inverter compressor drive malfunction(IDU P4/ PC04)

The trouble shooting is same with IPM module protection.

10.3.1.9 Communication malfunction between indoor two chips (IDU FA/EH0b)

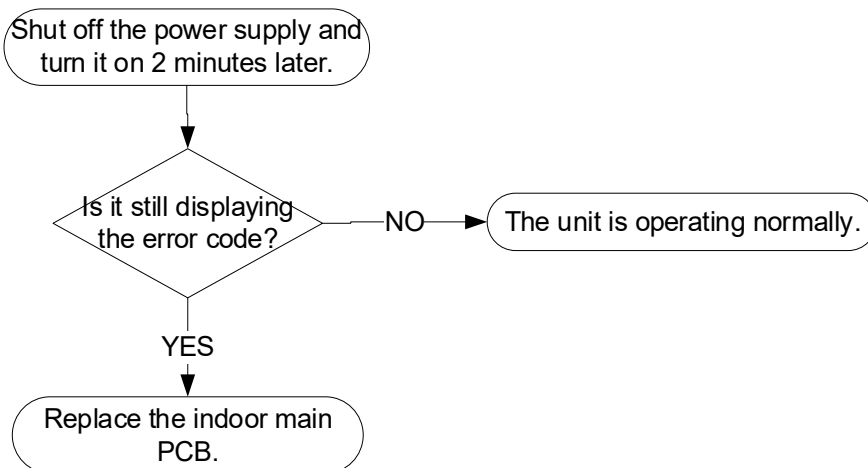

10.3.1.10 Refrigerant Leakage Detection(IDU EC/ EL0C)

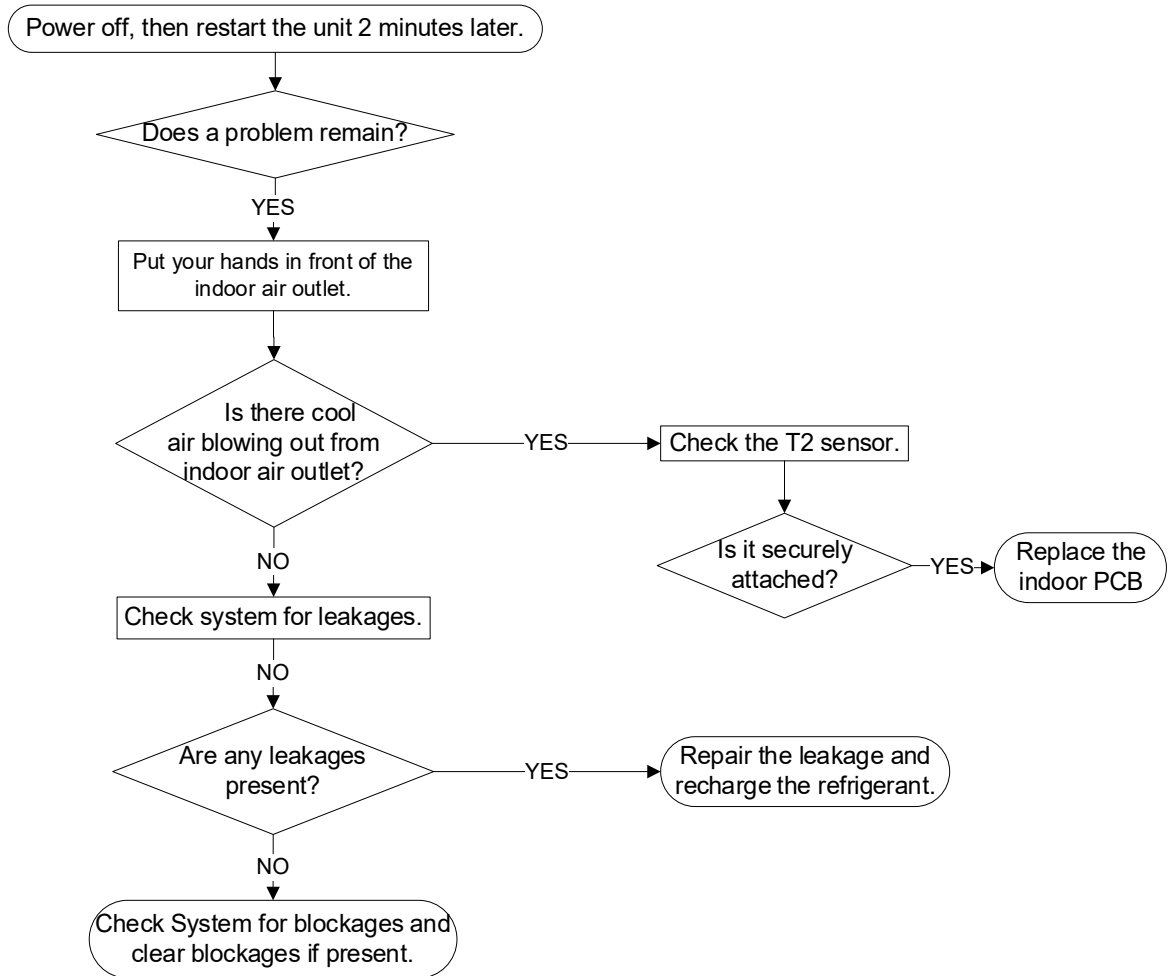

**10.3.1.11 Communication malfunction between external fan module and indoor unit(EHbA)
External fan DC bus voltage is too low protection(EH3A)
External fan DC bus voltage is too high fault(EH3b)**

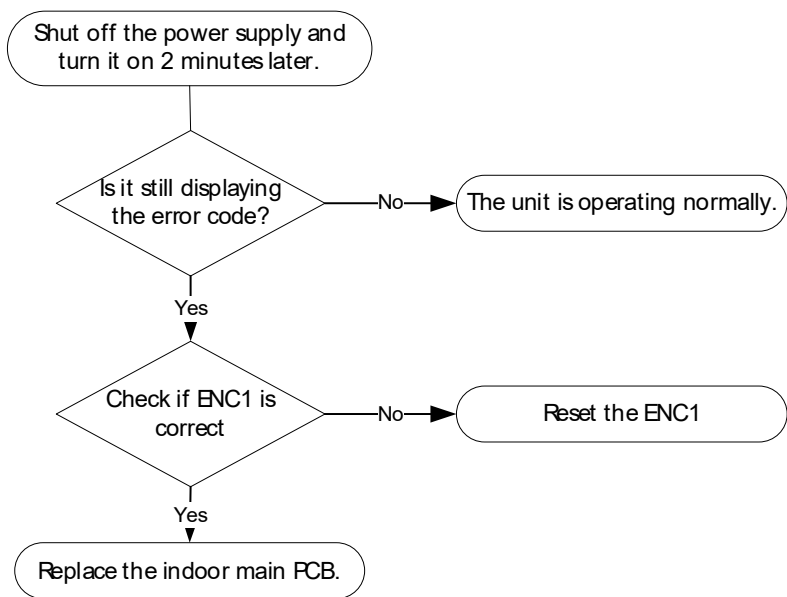

10.3.1.12 Communication malfunction between fresh air motor module and indoor unit diagnosis and solution(EHbA)(GAIA type)

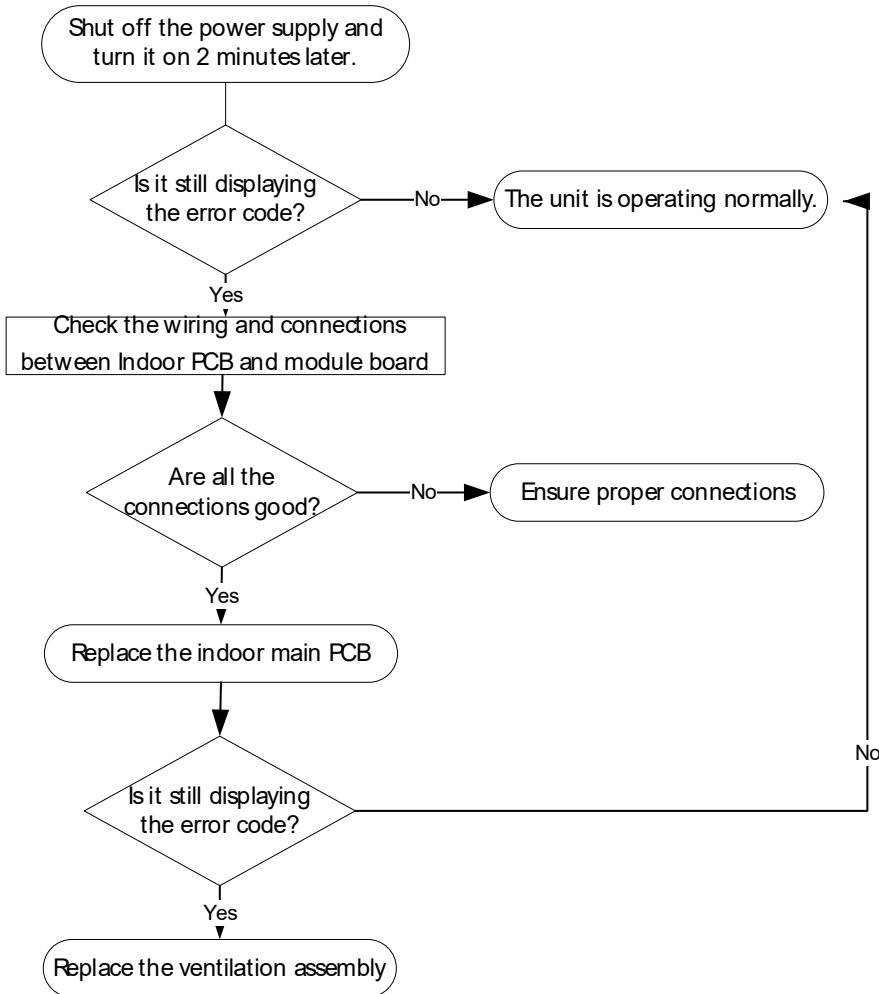

10.3.1.13 Fresh air motor DC bus voltage is too low protection(EH3A) or Fresh air motor DC bus voltage is too high fault(EH3b) or Fresh air motor malfunction (EH3C) or Fresh air temperature sensor TO is in open circuit or has short circuited(EH62) diagnosis and solution(GAIA type)

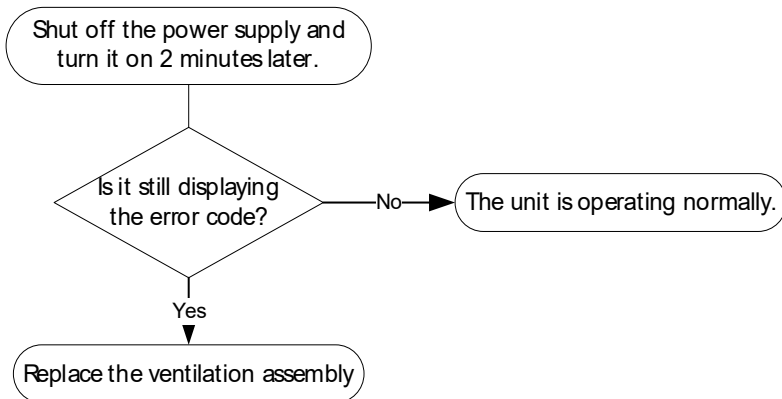

10.3.3 For the outdoor unit

10.3.3.1 Outdoor EEPROM malfunction(ODU E0/EC51)

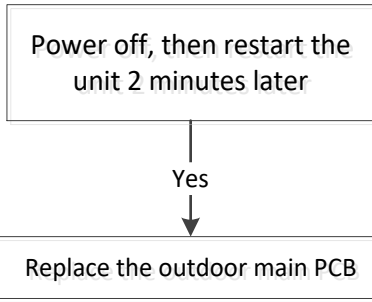

EEPROM: An electrically erasable programmable read-only memory whose contents can be erased and reprogrammed using a pulsed voltage.

10.3.3.2 Condenser coil temperature sensor T3 is in open circuit or has short circuited(EC52)

Outdoor room temperature sensor T4 is in open circuit or has short circuited(EC53)

Compressor discharge temperature sensor TP is in open circuit or has short circuited(EC54)

Evaporator coil outlet temperature sensor T2B is in open circuit or has short circuited(EC56)

IGBT temperature sensor TH is in open circuit or has short circuited(EC55)

Open or short circuit of outdoor unit temperature sensor(T3,T4.TP)(E4/ EC50)

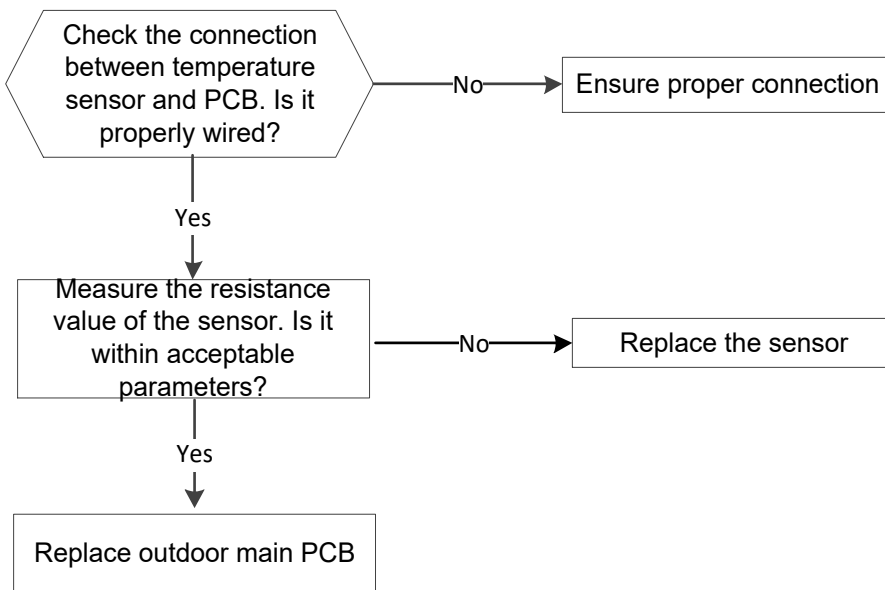

10.3.3.3 Communication malfunction between IPM board and outdoor main board(ODU E3/PC40)

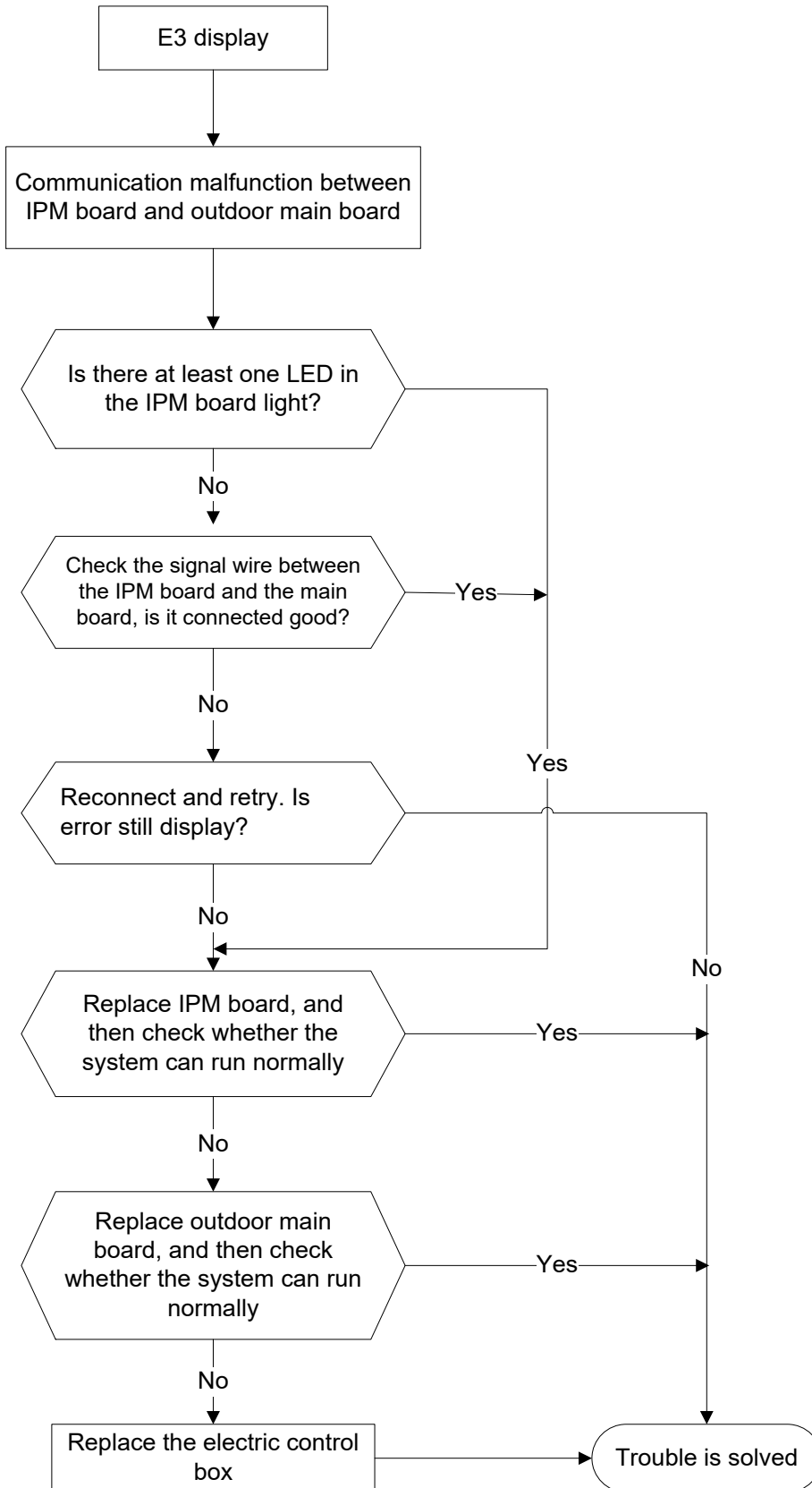

10.3.3.4 Voltage protection(ODU E5)

Outdoor unit low AC voltage protection(PC10)

Outdoor unit main control board DC bus high voltage protection(PC11)

Outdoor unit main control board DC bus high voltage protection /341 MCE error(PC12)

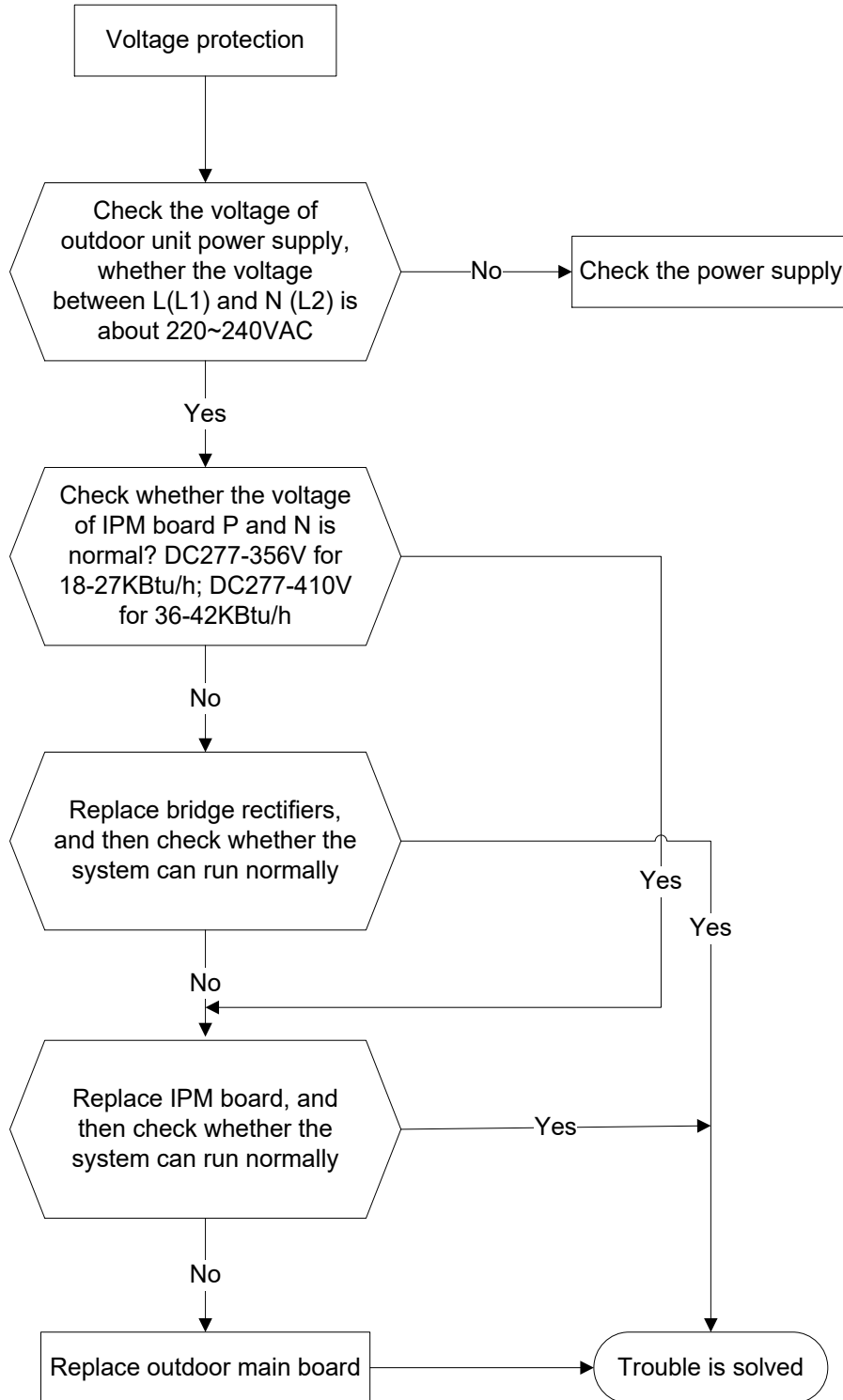

10.3.3.5 PFC module protection (ODU E6/PC0F)

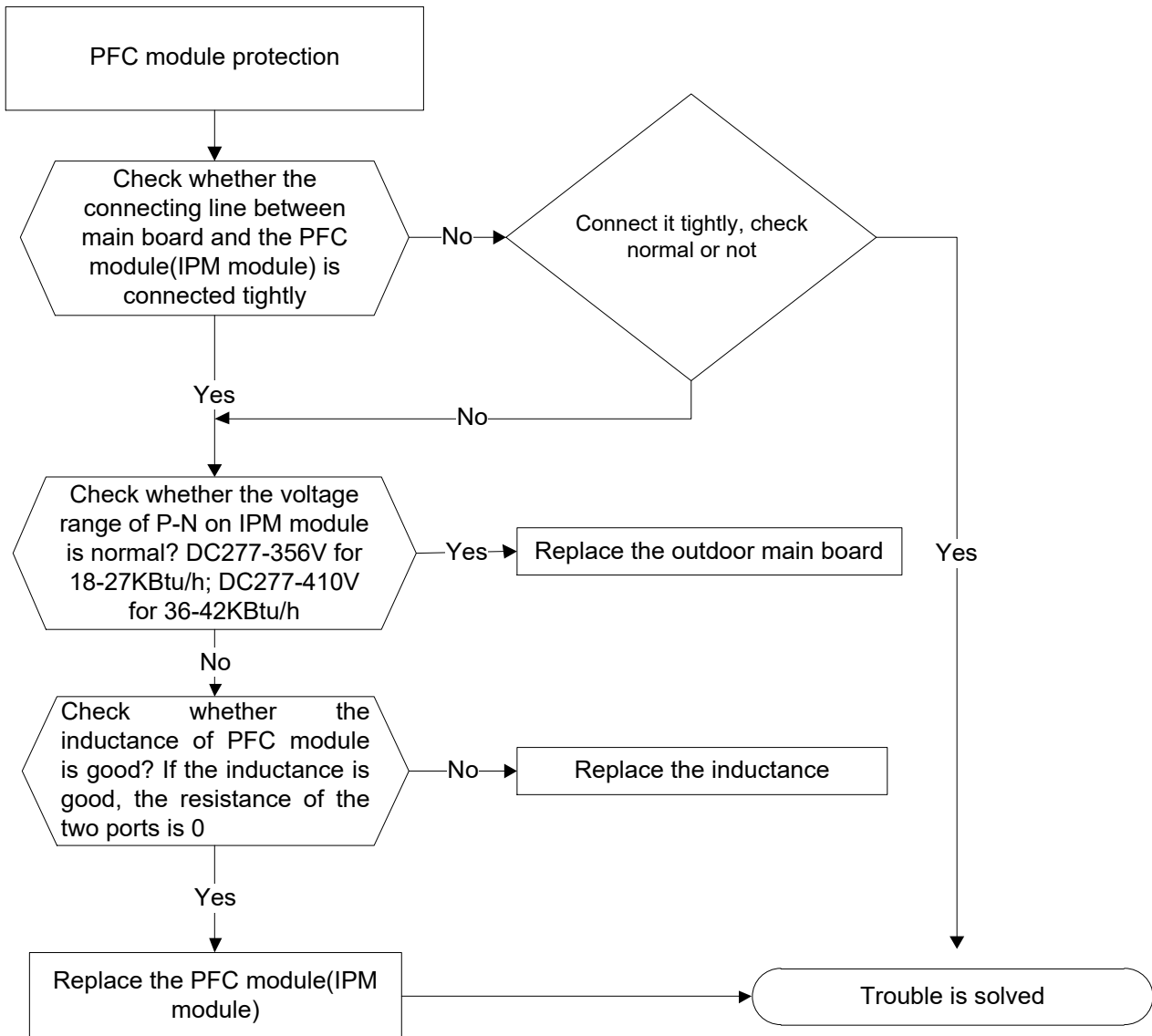

10.3.3.6 Outdoor fan speed has been out of control or compressor speed has been out of control (ODU E8/EC07)

Over current failure of outdoor DC fan motor (ODU EC71)

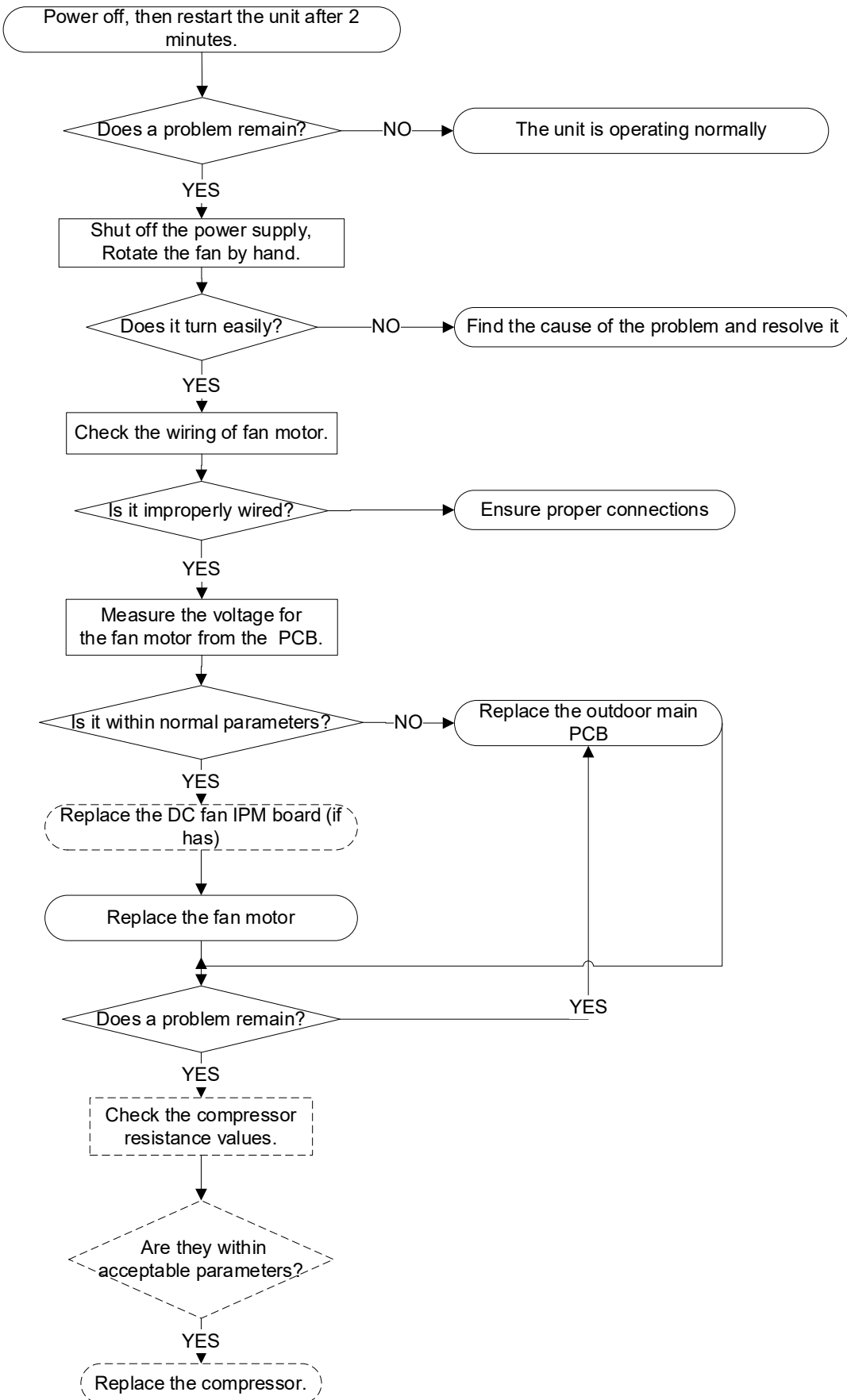

Index 1:

1. Outdoor DC fan motor(control chip is inside fan motor)

Power on and when the unit is in standby, measure the voltage of pin1-pin3, pin4-pin3 in fan motor connector. If the value of the voltage is not in the range showing in below table, the PCB must have problems and need to be replaced.

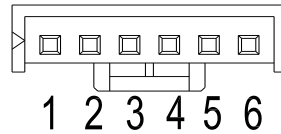

DC motor voltage input and output

NO.	Color	Signal	Voltage
1	Red	Vs/Vm	140V~380V
2	---	---	---
3	Black	GND	0V
4	White	Vcc	13.5-16.5V
5	Yellow	Vsp	0~6.5V
6	Blue	FG	15V

2. Indoor or outdoor DC Fan Motor (control chip is in PCB)

Release the UVW connector. Measure the resistance of U-V, U-W, and V-W. If the resistances are not equal to each other, the fan motor may be experiencing problems and need to be replaced. Otherwise, the PCB must has problems and need to be replaced.

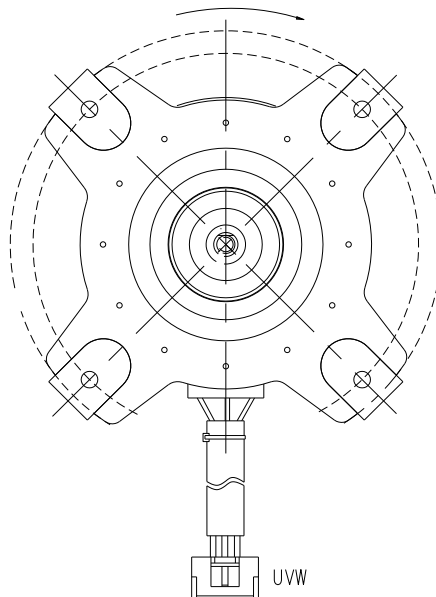

3. DC Fan Motor(for some double fan models)

Power on and when the unit is in standby, measure the voltage of CON1, pin1-pin2 and pin3-pin2 of CN1 in DC motor driver board. If the value of the voltage is not in the range showing in below tables, the outdoor main PCB must has problems and need to be replaced.

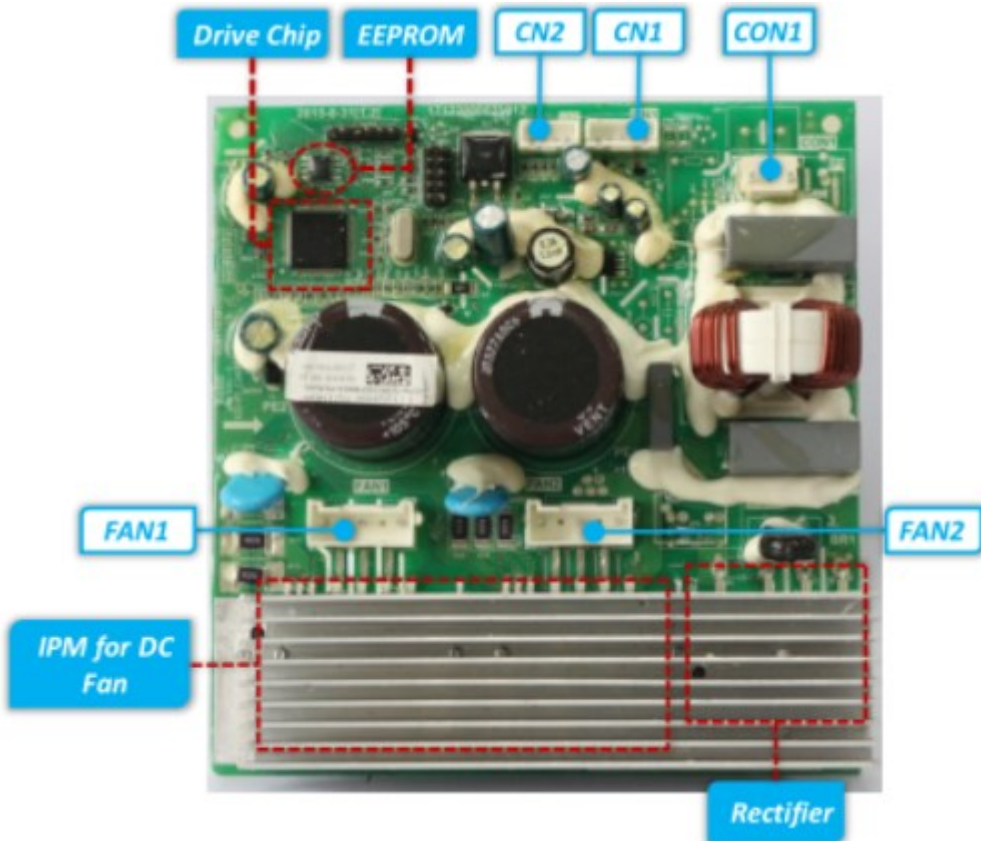

Port	Description	Parameter	Remark
CON1	Power input for the PCB	192-380V/DC	
CN1	Communication with main PCB	DC	
CN2	Test port	5V/DC	For debugging board
FAN1	UVW output for DC fan motor		
FAN2	UVW output for DC fan motor		

CN1 Communication with main PCB

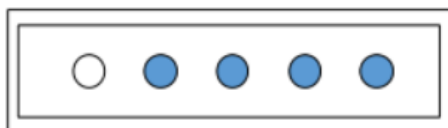

NO.	Signal	Voltage
1	Vcc	+15V
2	GND	
3	TXD	0~6V
4	RXD	0~15V
5	--	--

10.3.3.7 High pressure protection (ODU P1/PC30)

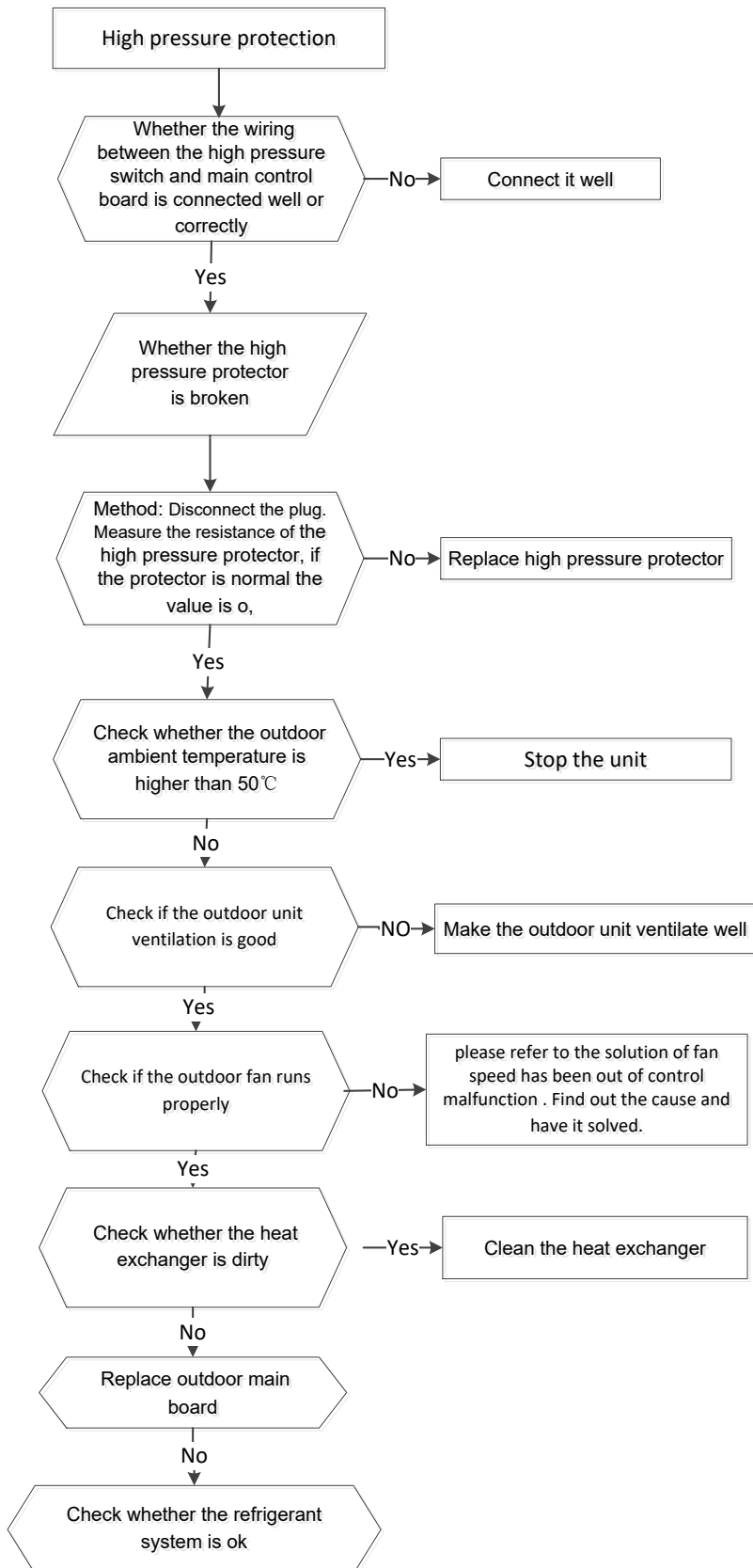

10.3.3.8 Low pressure protection (ODU P2/PC31)

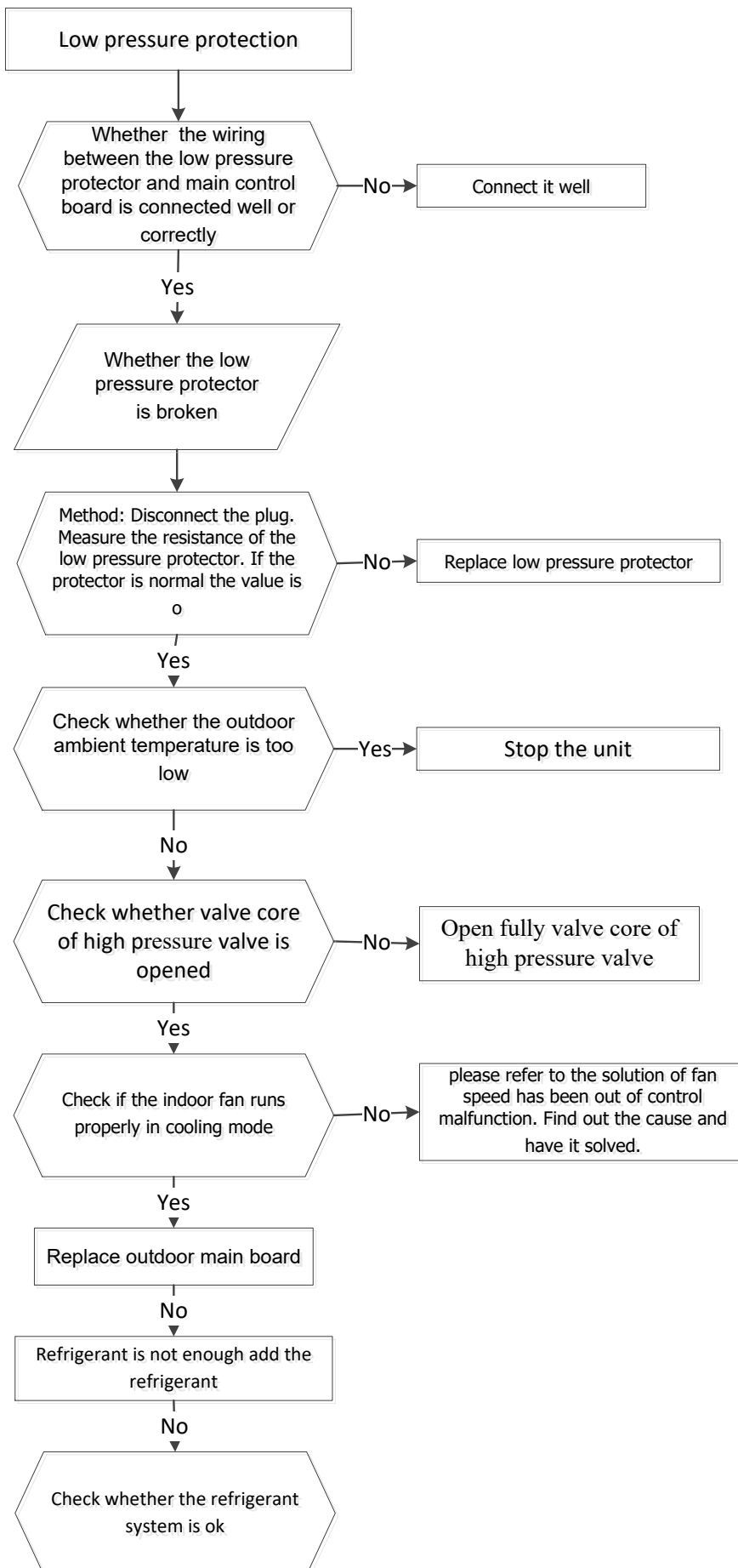

10.3.3.9 Current protection of compressor (ODU P3/PC08)
Outdoor unit zero speed protection(ODU PC44)
Compressor speed has been out of control(ODU PC46)
Compressor overcurrent failure(ODU PC49)

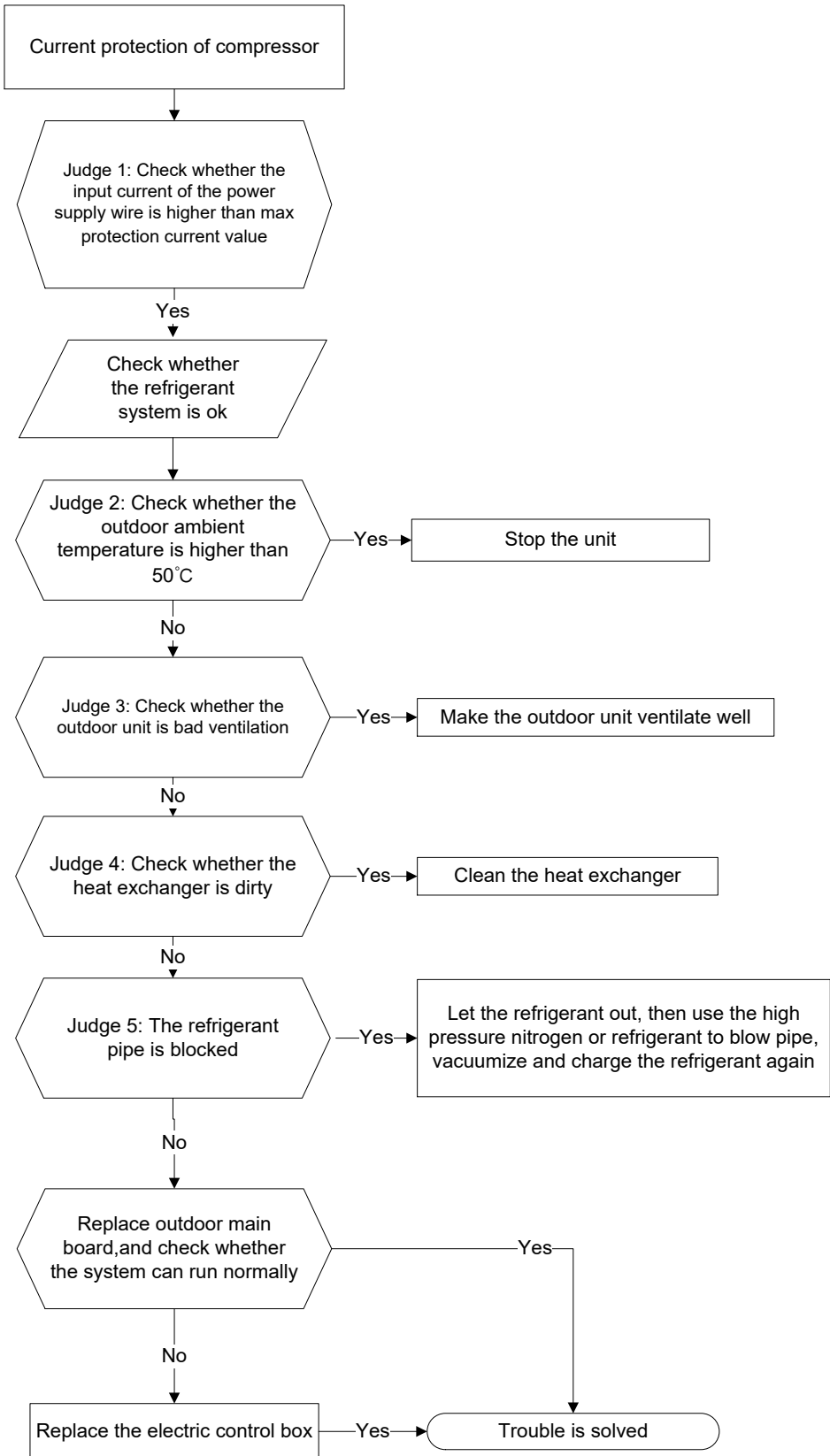

10.3.3.10 Temperature protection of compressor discharge (ODU P4/ PC06)

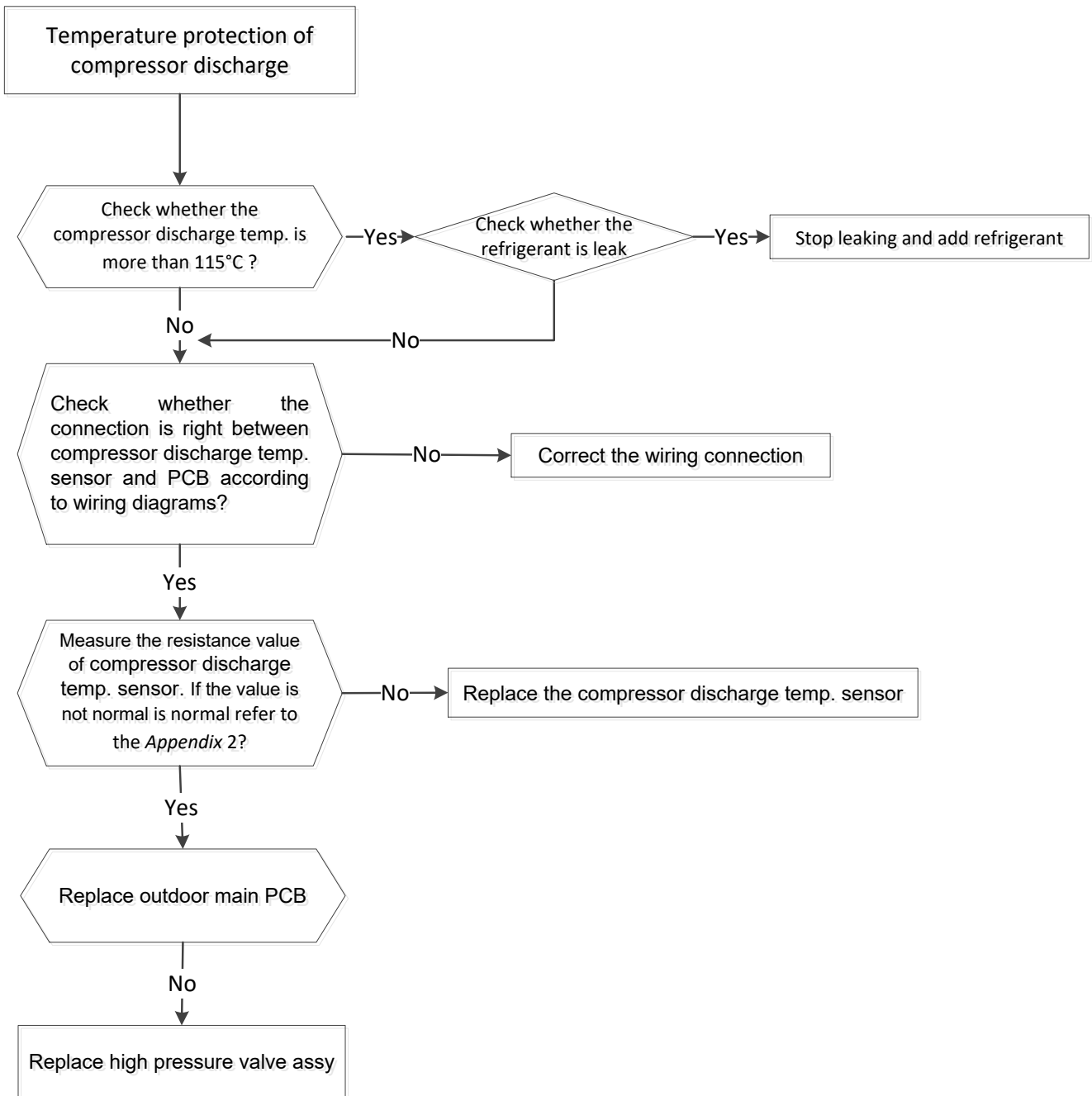

10.3.3.11 High temperature protection of condenser (ODU P5/ PC0A)

When outdoor pipe temperature is more than 65°C, the unit will stop, and unit runs again when outdoor pipe temperature less than 52°C.

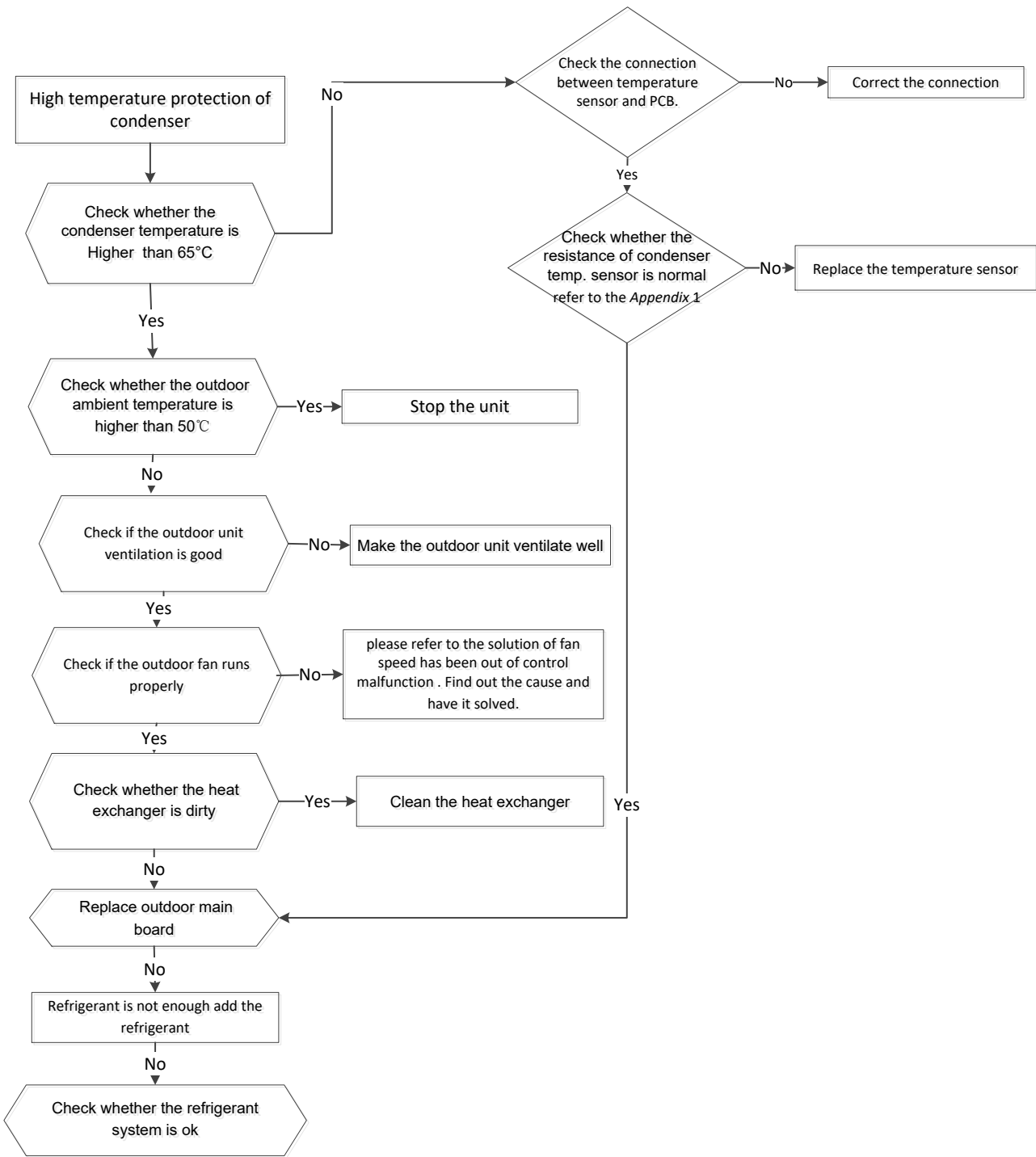

10.3.3.12 IPM module protection (ODU P6/PC00)

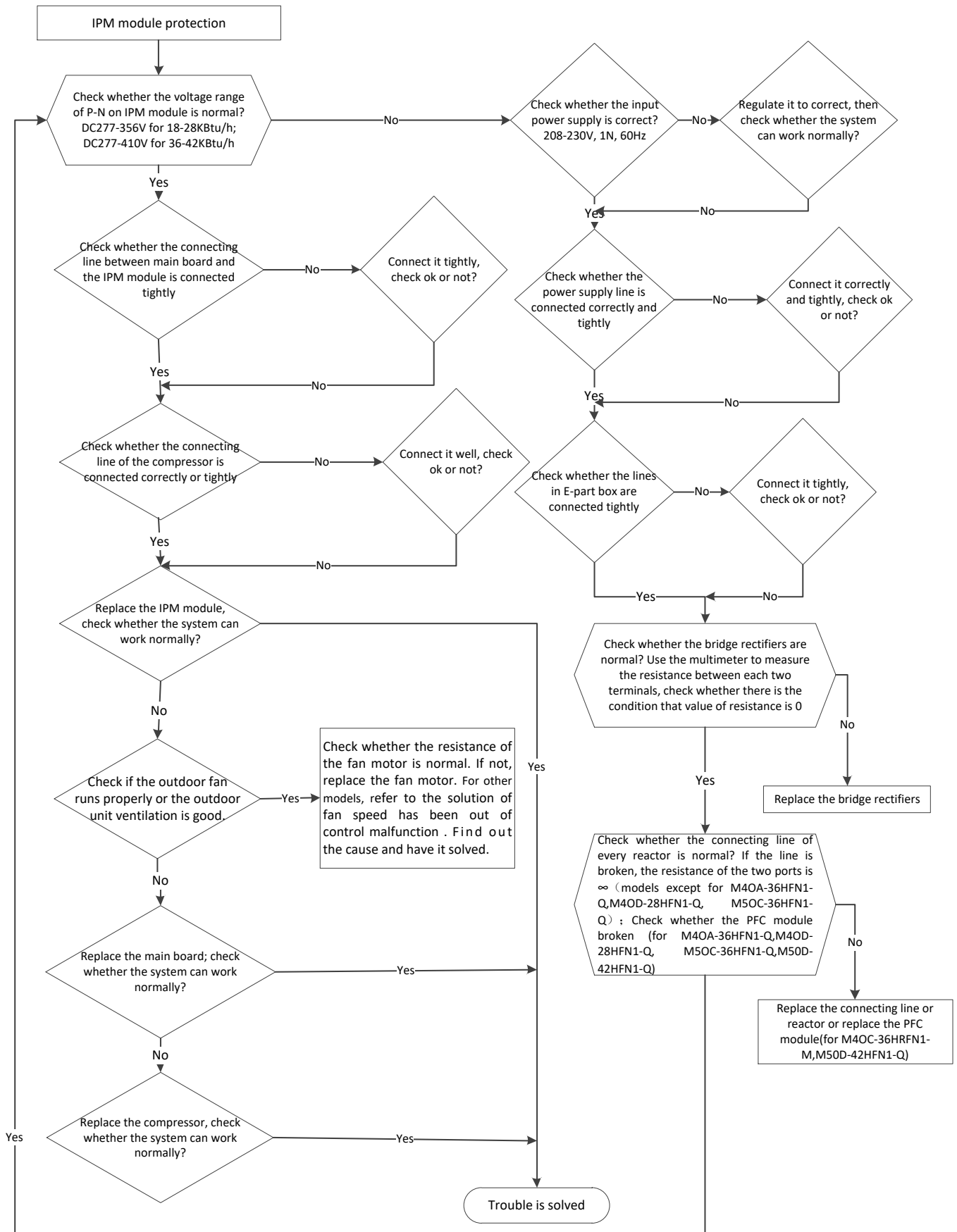

10.3.3.13 Top temperature protection of compressor (ODU P0/ PC02)

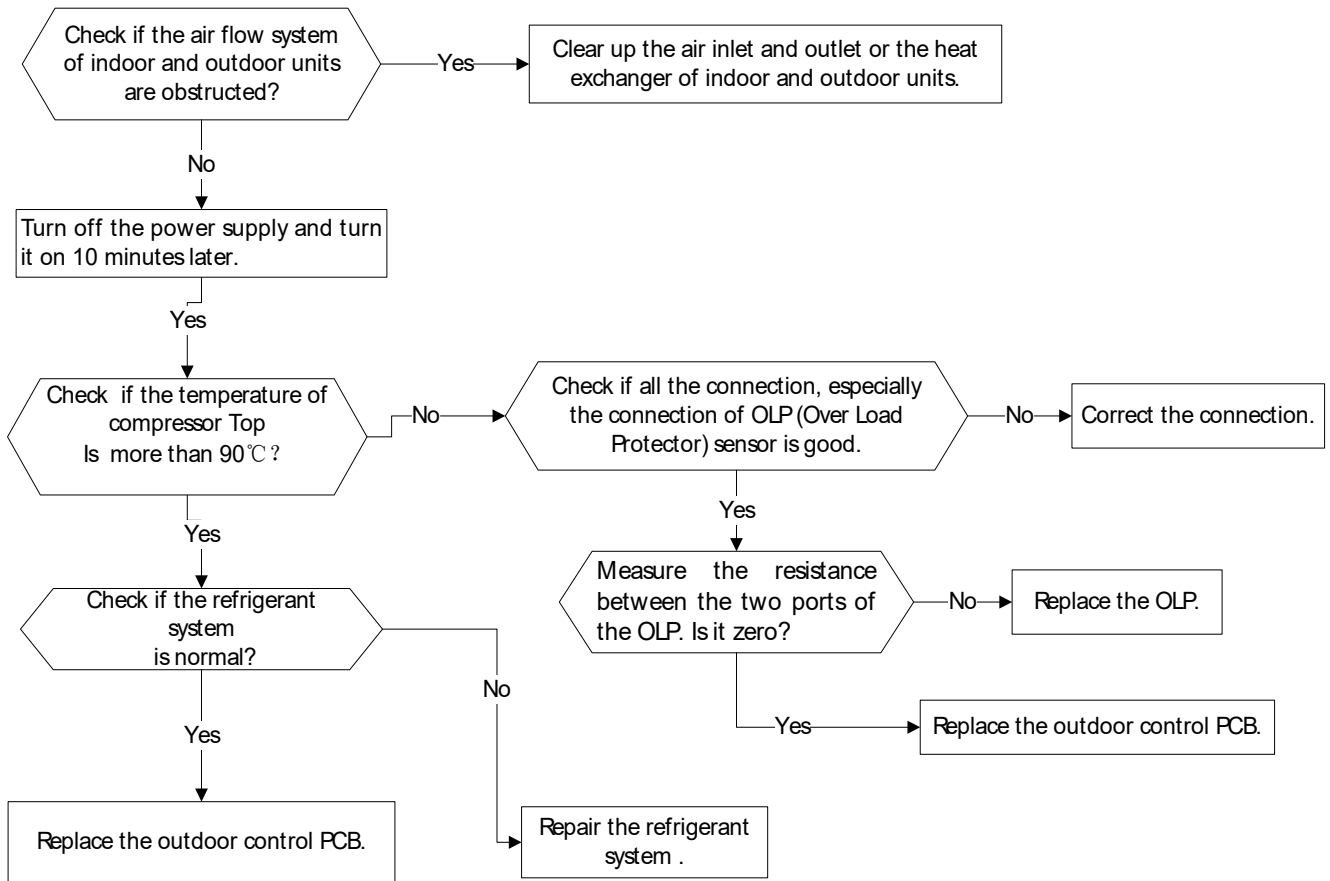

10.3.3.14 Lack phase failure of outdoor DC fan motor(EC72)

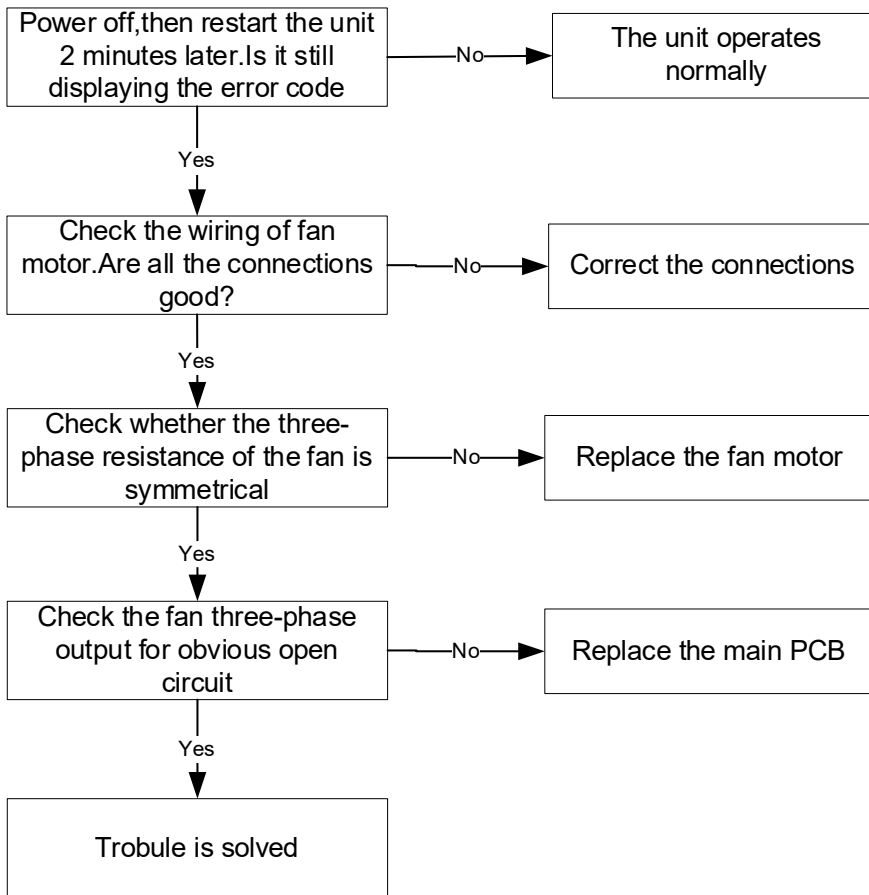

10.3.3.15 Outdoor compressor lack phase protection(PC43)

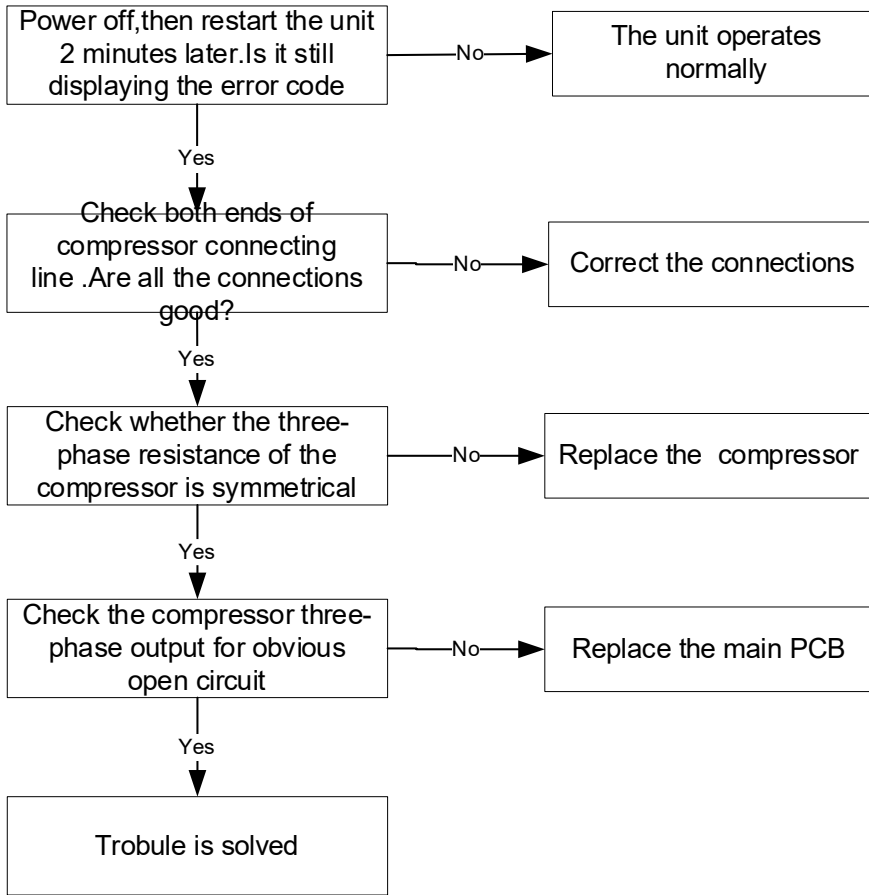

10.3.3.16 Outdoor unit IR chip drive failure(PC45)

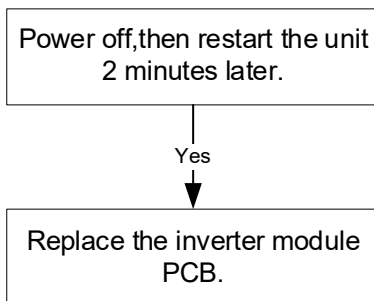

10.3.3.17 TW_out high temperature protection(PC61)

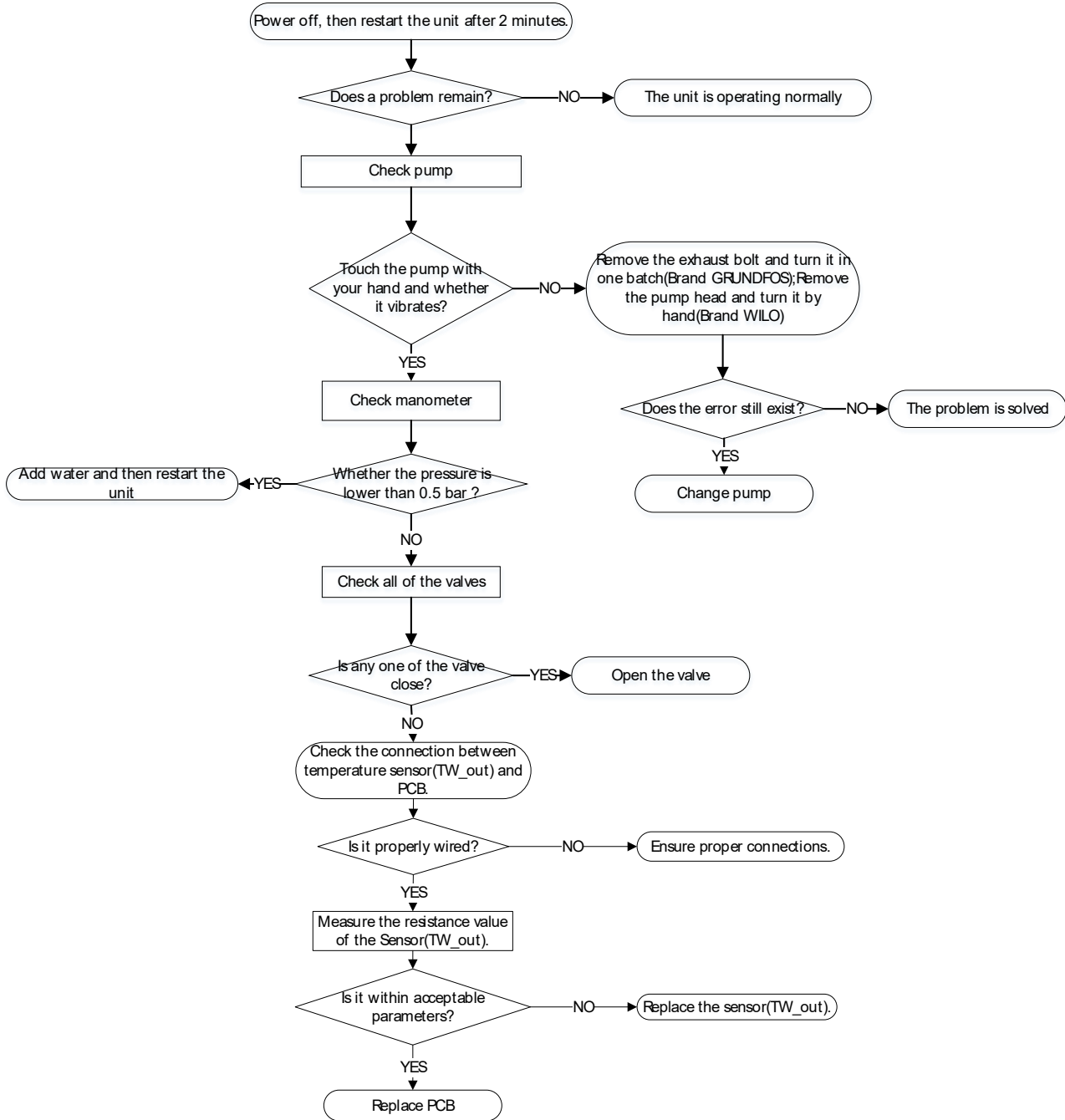

10.3.3.18 TR_in high temperature protection (PC65)

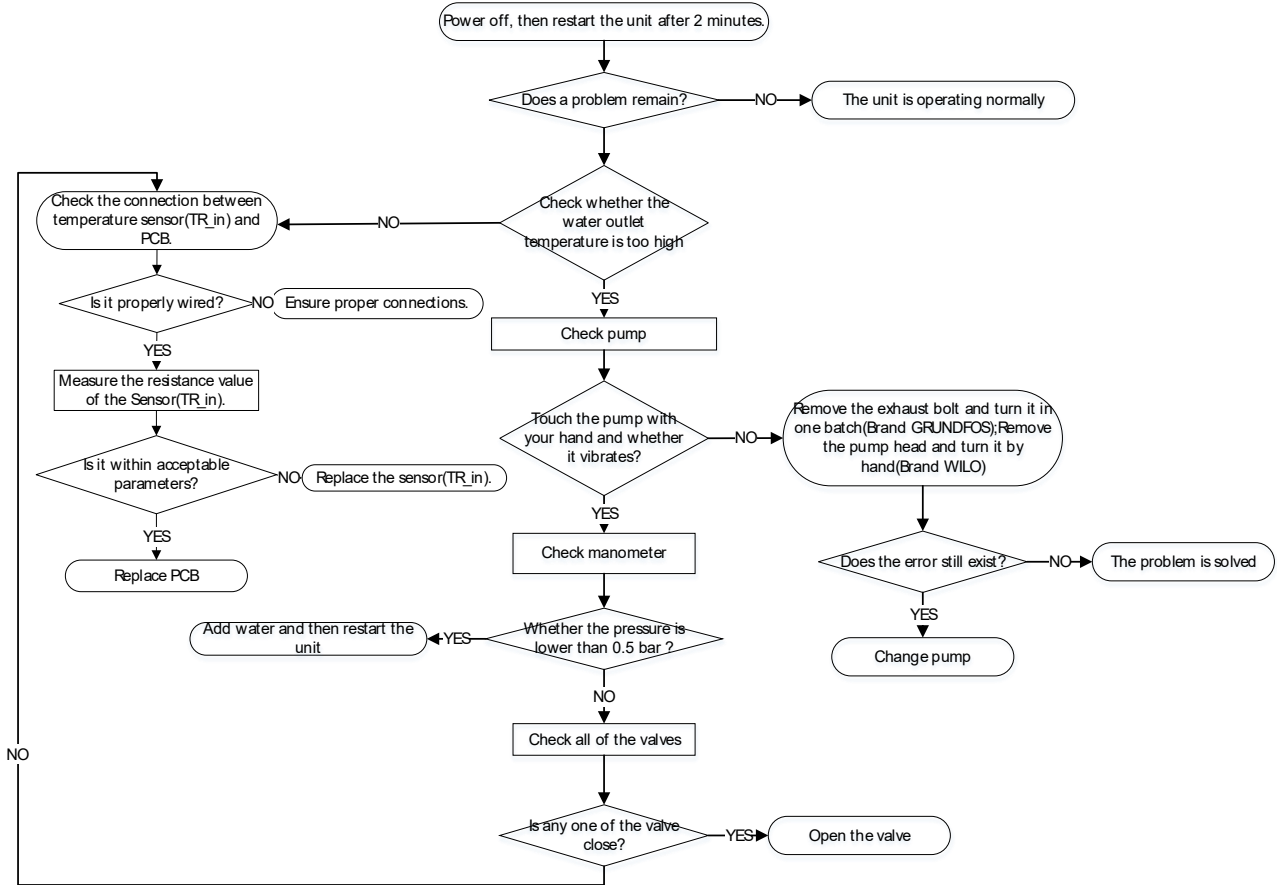

10.3.3.19 Defrosting water temperature too low protection

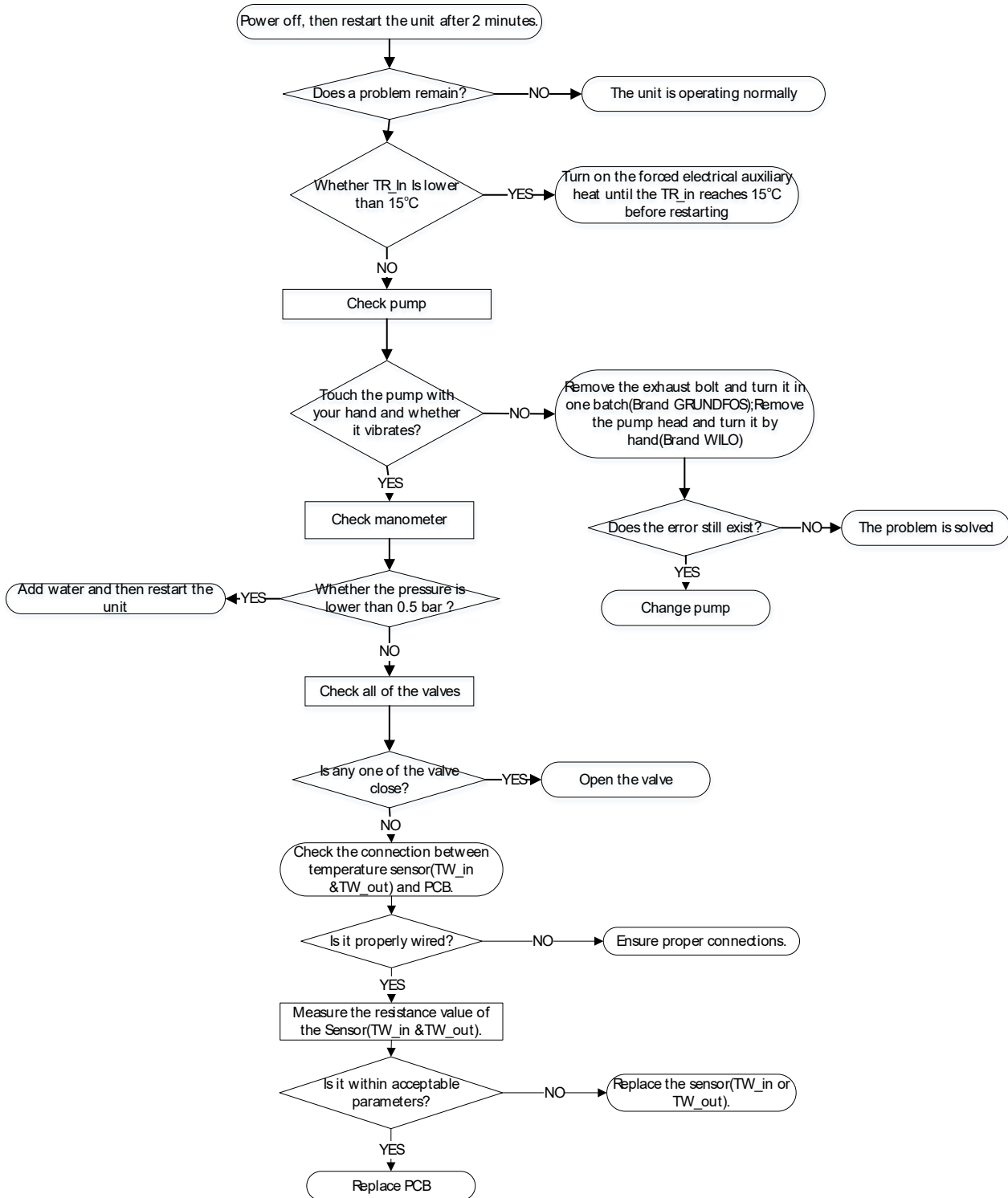

10.3.3.20 The cooling operation or heating operation does not operate.

Potential causes

- Faulty 4-way valve

Check of 4-way, please refer to part 4 in 10.4 Trouble Criterion Of Main Parts.

10.3.3.21 When cooling, heat exchanger of non-operating indoor unit frosts.

When heating, non-operating indoor unit get warm.

Potential causes

- Faulty EXV
- Wire and piping connected in reverse.

Check of EXV, please refer to part 5 in 10.4 Trouble Criterion Of Main Parts.

10.3.3.22 Automatic correction of wiring/piping error:

Press the "check switch" on the outdoor unit PCB board 5 seconds until LED display "CE", which mean this function is working, Approximately 5-10 minutes after the switch is pressed, the "CE" disappear the wiring/piping error will be corrected, and wiring/piping is properly connected.

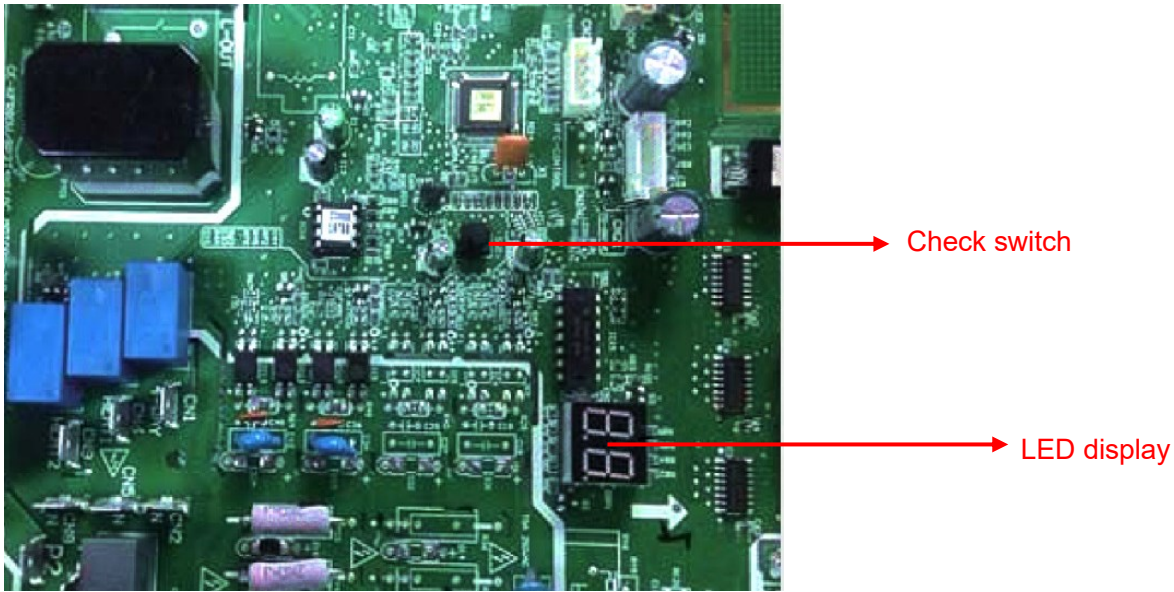

10.3.3.23 If LED display “88”, it shows that air conditioning failed.

Potential causes

- Wiring mistake or faulty wiring.
- Power failure
- Faulty main control board

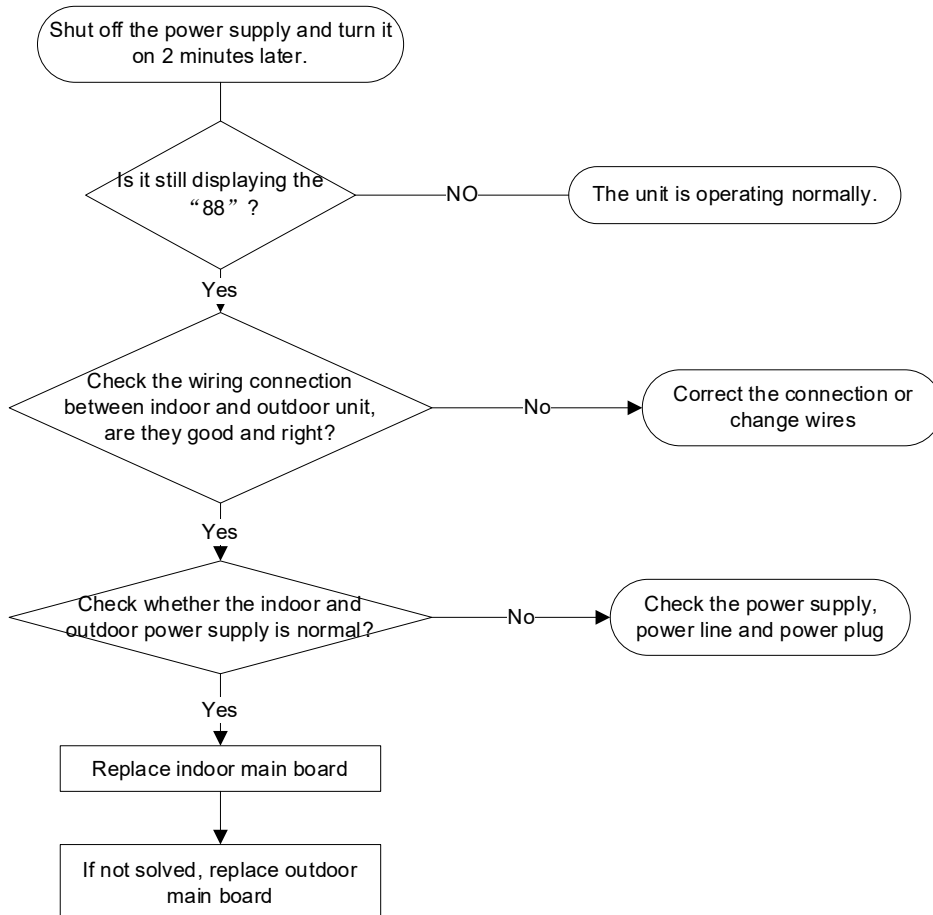

10.4 Main parts check

1. Temperature sensor checking

Disconnect the temperature sensor from PCB, measure the resistance value with a tester.

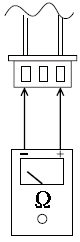

Tester

Temperature Sensors.

Room temperature(T1) sensor,

Indoor coil temperature(T2) sensor,

Outdoor coil temperature(T3) sensor,

Outdoor ambient temperature(T4) sensor,

Compressor discharge temperature(TP) sensor.

Measure the resistance value of each winding by using the multi-meter.

Appendix 1 Temperature Sensor Resistance Value Table for T1,T2,T3,T4,T2B (°C--K)

°C	K Ohm	°C	K Ohm	°C	K Ohm	°C	K Ohm
-20	115.266	20	12.6431	60	2.35774	100	0.62973
-19	108.146	21	12.0561	61	2.27249	101	0.61148
-18	101.517	22	11.5000	62	2.19073	102	0.59386
-17	96.3423	23	10.9731	63	2.11241	103	0.57683
-16	89.5865	24	10.4736	64	2.03732	104	0.56038
-15	84.2190	25	10.000	65	1.96532	105	0.54448
-14	79.3110	26	9.55074	66	1.89627	106	0.52912
-13	74.5360	27	9.12445	67	1.83003	107	0.51426
-12	70.1698	28	8.71983	68	1.76647	108	0.49989
-11	66.0898	29	8.33566	69	1.70547	109	0.48600
-10	62.2756	30	7.97078	70	1.64691	110	0.47256
-9	58.7079	31	7.62411	71	1.59068	111	0.45957
-8	56.3694	32	7.29464	72	1.53668	112	0.44699
-7	52.2438	33	6.98142	73	1.48481	113	0.43482
-6	49.3161	34	6.68355	74	1.43498	114	0.42304
-5	46.5725	35	6.40021	75	1.38703	115	0.41164
-4	44.0000	36	6.13059	76	1.34105	116	0.40060
-3	41.5878	37	5.87359	77	1.29078	117	0.38991
-2	39.8239	38	5.62961	78	1.25423	118	0.37956
-1	37.1988	39	5.39689	79	1.21330	119	0.36954
0	35.2024	40	5.17519	80	1.17393	120	0.35982
1	33.3269	41	4.96392	81	1.13604	121	0.35042
2	31.5635	42	4.76253	82	1.09958	122	0.3413
3	29.9058	43	4.57050	83	1.06448	123	0.33246
4	28.3459	44	4.38736	84	1.03069	124	0.32390
5	26.8778	45	4.21263	85	0.99815	125	0.31559
6	25.4954	46	4.04589	86	0.96681	126	0.30754
7	24.1932	47	3.88673	87	0.93662	127	0.29974
8	22.5662	48	3.73476	88	0.90753	128	0.29216
9	21.8094	49	3.58962	89	0.87950	129	0.28482
10	20.7184	50	3.45097	90	0.85248	130	0.27770
11	19.6891	51	3.31847	91	0.82643	131	0.27078
12	18.7177	52	3.19183	92	0.80132	132	0.26408
13	17.8005	53	3.07075	93	0.77709	133	0.25757
14	16.9341	54	2.95896	94	0.75373	134	0.25125
15	16.1156	55	2.84421	95	0.73119	135	0.24512
16	15.3418	56	2.73823	96	0.70944	136	0.23916
17	14.6181	57	2.63682	97	0.68844	137	0.23338
18	13.9180	58	2.53973	98	0.66818	138	0.22776
19	13.2631	59	2.44677	99	0.64862	139	0.22231

Appendix 2 Temperature Sensor Resistance Value Table for TP (°C--K)

°C	K Ohm	°C	K Ohm	°C	K Ohm	°C	K Ohm
-20	542.7	20	68.66	60	13.59	100	3.702
-19	511.9	21	65.62	61	13.11	101	3.595
-18	483	22	62.73	62	12.65	102	3.492
-17	455.9	23	59.98	63	12.21	103	3.392
-16	430.5	24	57.37	64	11.79	104	3.296
-15	406.7	25	54.89	65	11.38	105	3.203
-14	384.3	26	52.53	66	10.99	106	3.113
-13	363.3	27	50.28	67	10.61	107	3.025
-12	343.6	28	48.14	68	10.25	108	2.941
-11	325.1	29	46.11	69	9.902	109	2.86
-10	307.7	30	44.17	70	9.569	110	2.781
-9	291.3	31	42.33	71	9.248	111	2.704
-8	275.9	32	40.57	72	8.94	112	2.63
-7	261.4	33	38.89	73	8.643	113	2.559
-6	247.8	34	37.3	74	8.358	114	2.489
-5	234.9	35	35.78	75	8.084	115	2.422
-4	222.8	36	34.32	76	7.82	116	2.357
-3	211.4	37	32.94	77	7.566	117	2.294
-2	200.7	38	31.62	78	7.321	118	2.233
-1	190.5	39	30.36	79	7.086	119	2.174
0	180.9	40	29.15	80	6.859	120	2.117
1	171.9	41	28	81	6.641	121	2.061
2	163.3	42	26.9	82	6.43	122	2.007
3	155.2	43	25.86	83	6.228	123	1.955
4	147.6	44	24.85	84	6.033	124	1.905
5	140.4	45	23.89	85	5.844	125	1.856
6	133.5	46	22.89	86	5.663	126	1.808
7	127.1	47	22.1	87	5.488	127	1.762
8	121	48	21.26	88	5.32	128	1.717
9	115.2	49	20.46	89	5.157	129	1.674
10	109.8	50	19.69	90	5	130	1.632
11	104.6	51	18.96	91	4.849		
12	99.69	52	18.26	92	4.703		
13	95.05	53	17.58	93	4.562		
14	90.66	54	16.94	94	4.426		
15	86.49	55	16.32	95	4.294	B(25/50)=3950K	
16	82.54	56	15.73	96	4.167		
17	78.79	57	15.16	97	4.045	R(90°C)=5KΩ±3%	
18	75.24	58	14.62	98	3.927		
19	71.86	59	14.09	99	3.812		

2.Compressor checking

Measure the resistance value of each winding by using the tester.

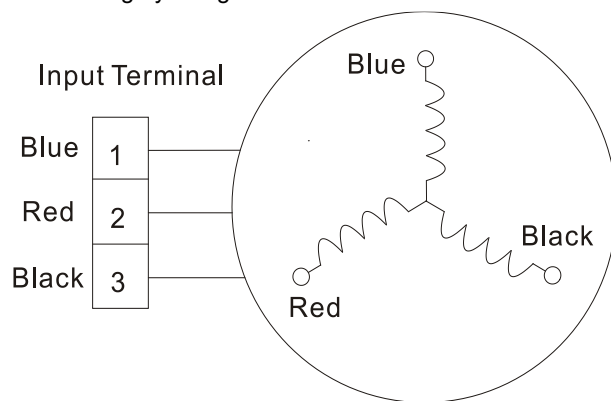

Position	Resistance Value		
		KSM135D23UFZ	KTF235D22UMT
Blue - Red	1.72Ω(20°C)	0.75Ω(20°C)	0.65Ω(20°C)



3. IPM continuity check

Turn off the power, let the large capacity electrolytic capacitors discharge completely, and dismount the IPM. Use a digital tester to measure the resistance between P and UVWN; UVW and N.

Digital tester		Normal resistance value	Digital tester		Normal resistance value
(+)Red	(-)Black		(+)Red	(-)Black	
P	N	∞ (Several M Ω)	U	N	∞ (Several M Ω)
	U				
	V				
	W				
			(+)Red		

4.4-way valve

1. Power on, use a digital tester to measure the voltage, when the unit operates in cooling, it is 0V. When the unit operates in heating, it is about 230VAC.

If the value of the voltage is not in the range, the PCB must have problems and need to be replaced.

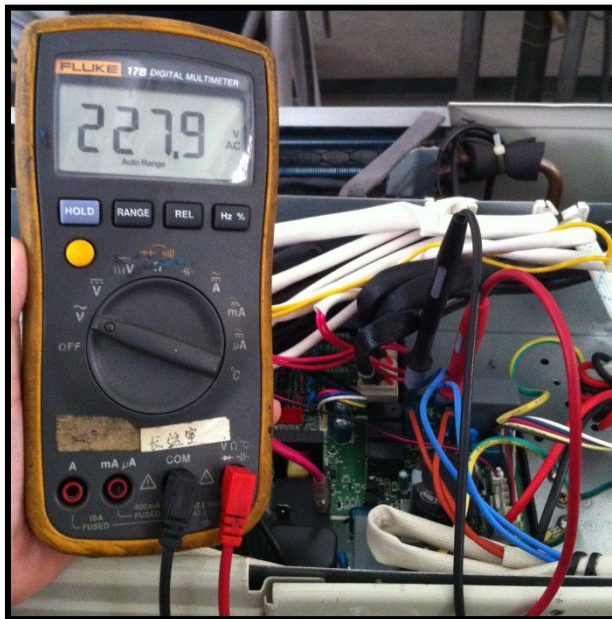

2 Turn off the power, use a digital tester to measure the resistance. The value should be 1.8~2.5 K Ω .

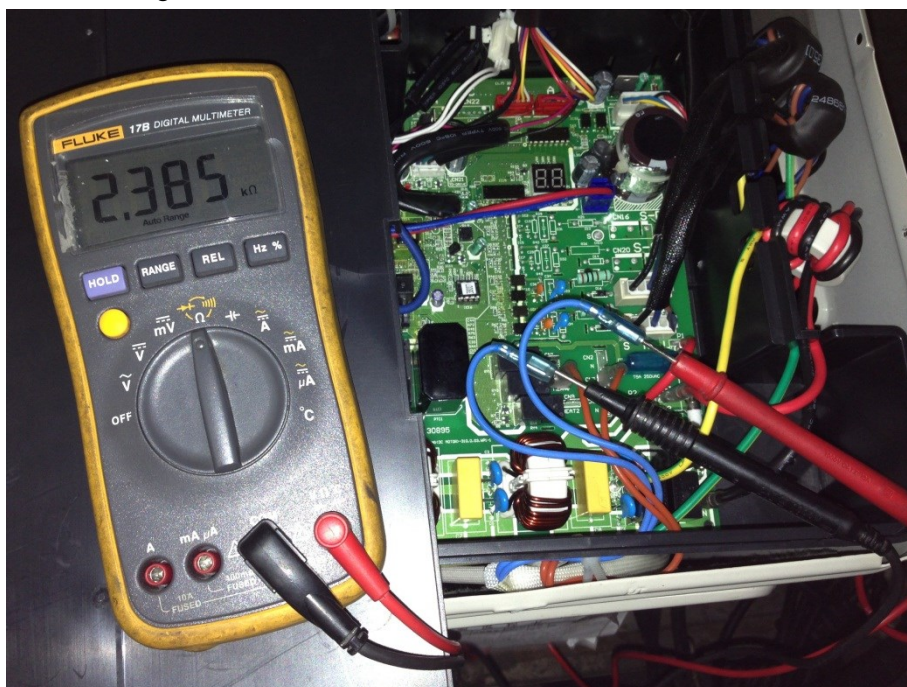

5.EXV check

Disconnect the connectors.

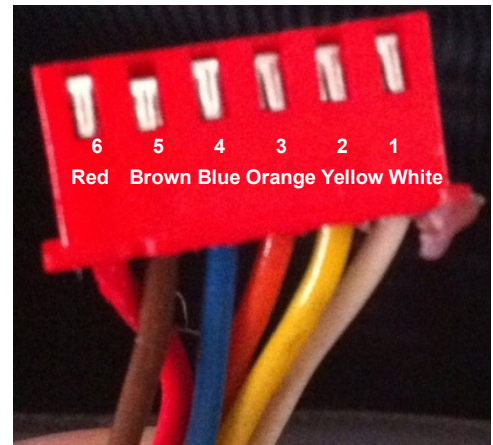
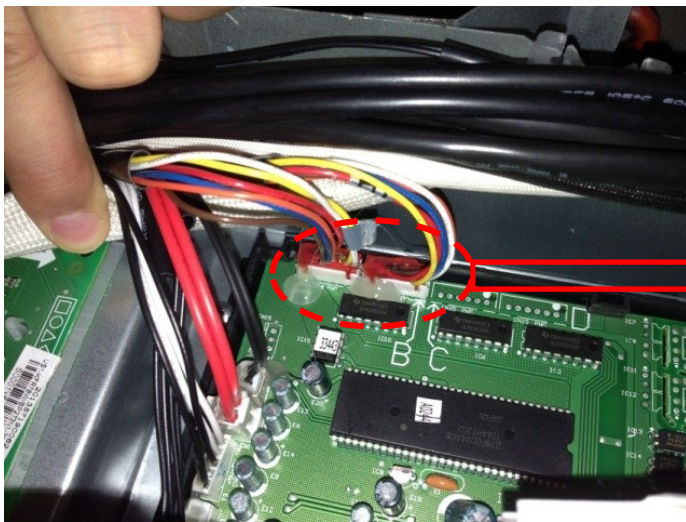
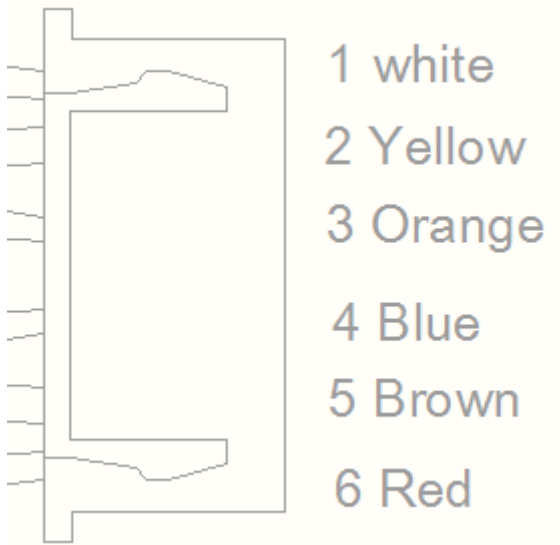

Resistance to EXV coil

Color of lead wire	Normal Value
Red- Blue	About 50Ω
Red - Yellow	
Brown-Orange	