

en

**BAXI**



## **Installation & maintenance manual**

**Condenser units with compressor and axial fan**

**UMXCBA / UMXCA**

**Models: 801.1 | 1001.1 | 1201.1 | 1501.1 | 1602.2 | 2002.2 | 2402.2 | 3002.2 | 3502.2 |  
4002.2 | 4502.2**

**Cooling Capacities: from 25.9 kW to 134.7 kW**

**Heating Capacities: from 27.3 kW to 142.4 Kw**

# TABLE OF CONTENT

<b>TABLE OF CONTENT</b> .....	<b>2</b>
<b>INTRODUCTION</b> .....	<b>4</b>
<b>REGULATIONS AND CERTIFICATIONS</b> .....	<b>5</b>
<b>SAFETY INSTRUCTIONS</b> .....	<b>6</b>
<b>TECHNICAL SPECIFICATIONS</b> .....	<b>7</b>
<b>TRANSPORT</b> .....	<b>10</b>
INSPECTION AT RECEPTION .....	10
RIGGING.....	10
STORAGE.....	10
<b>INSTALLATION</b> .....	<b>11</b>
INSTALLATION SITE.....	11
UNIT SETTLEMENT .....	11
SERVICE AREA.....	11
WEIGHT DISTRIBUTION (KG) .....	12
WATER DRAIN .....	12
AIR DUCTS .....	12
<b>REFRIGERANT LINES</b> .....	<b>13</b>
<i>Refrigerant circuit</i> .....	13
<i>Discharge lines</i> .....	13
<b>LINE DESIGN</b> .....	13
REFRIGERANT LINES .....	14
LINE DRAWING.....	14
<i>Additional load in the interconnection pipes</i> .....	15
<b>REFRIGERATION CONNECTIONS</b> .....	16
<i>Guidelines for the correct installation of the refrigeration connections</i> .....	16
<b>ELECTRICAL INSTALLATION</b> .....	17
<b>ELECTRICAL DIAGRAM</b> .....	17
<i>pGD1 or Mini-pGD control</i> .....	18
<b>OPERATION</b> .....	<b>19</b>
BEFORE START-UP.....	19
START UP.....	20
INDOOR FAN TRANSMISSION ADJUSTMENT .....	20
OPERATION LIMITS.....	21
<b>TH-TUNE CONTROL</b> .....	22
<i>Display</i> .....	22
<i>Start / Stop</i> .....	22
<i>Setpoint Temperature Adjustment</i> .....	22
<i>Calibration of the Th-Tune internal temperature probe</i> .....	22
<i>Operation modes</i> .....	22
<i>Indoor Fan:</i> .....	23
<i>Programación horaria</i> .....	23
<i>Alarms</i> .....	24

PGD1 OR MINI PGD THERMOSTAT .....	25
KEYBOARD .....	25
<i>On / Off</i> .....	25
<i>Temperature adjustment</i> .....	25
<i>System operating modes change</i> .....	25
<i>Time Schedule</i> .....	26
<i>Local Network</i> .....	29
<i>Alarms</i> .....	30
<b>MAINTENANCE .....</b>	<b>32</b>
CONSERVATION AND CLEANING.....	32
COMPRESSOR LUBRICANT .....	33
REFRIGERANT CHARGE .....	33
<b>DIMENSIONS .....</b>	<b>34</b>
UMXCBA / UMXCA 801.1 – 1001.1 – 1201.1 – 1501.1 .....	34
UMXCBA / UMXCA 1602.2 – 2002.2 – 2402.2 – 3002.2 .....	35
UMXCBA / UMXCA 3502.2 – 4002.2 – 4502.2.....	36
<b>APPENDIX: SAFETY DATA R410A .....</b>	<b>37</b>

# INTRODUCTION

## Purpose of this Manual



The present manual together with any other technical document such as refrigeration or hydraulic lines drawings and electrical diagrams among others have been issued to provide the necessary information for installation, start-up and maintenance of the unit. Therefore it is essential to read the instructions very carefully. Please contact us if your machine is equipped with an option or any special modification that are not mentioned in the present manual.

Make sure that all the necessary information for the correct installation of the system is included in the manuals that have been supplied together with this unit and/or the rest of the indoor units, accessories, etc. The manufacturer declines any responsibility in case of people/animals injuries or material damages resulting from an incorrect use of the unit and/or non-compliance with these instructions.

In case of different interpretations and/or errors, the priority order of validity of the given documents will be 1. Nameplate of the unit stating the specifications. 2. IOM (the present document), 3. EDM, technical catalogue, 4. UM user manuals.

## Storage of the Manual

This manual and the electrical diagram of the unit must be preserved and remain available to the operator for any further consultation.

## Updating the Data

The continuous improvement in design and performance to which we are committed to gives us the right to modify the specifications of our products without prior notice.

## Electrical Supply



Check that the electrical network features comply with the data shown in the data nameplate of the unit.

## Local Safety Regulations

Observe and analyse all the possible causes of accidents that may arise in the place or places of installation of the units, check all the medium and the tools that will be used, etc. It is not possible to anticipate each one of the potential circumstances of danger in this manual. Respect the valid local security standards during installation.

## Principles of Security

The unit has been designed and built so that it does not represent any risk to the health and safety of people. Appropriate solutions for the project have been planned to eliminate the possible causes of risk during installation.

## Installation



Please read carefully the present document. Any damage to the equipment caused by an incorrect installation will not be covered by the insurance. Any installation operation shall be completed according to the instructions of the manufacturer and carried out by certified personnel. This document has been issued for installers, however, should you find the instructions not clear enough, please do not hesitate to contact us.

Reminder: all operations shall be completed according to the local security regulations.

## Utilization

The unit will be used only for the purpose it has been designed for. Any other use does not imply any kind of liability or responsibility from the manufacturer.

# INTRODUCTION

## Incorrect Operation

In case of breakdowns or operation faults, turn the unit off.

## Periodic Inspections and Maintenance



Carry out periodic inspections to detect possible damaged or broken parts. If these parts are not repaired, people injuries or material damages could be caused. Disconnect the power supply of the unit before carrying out any maintenance operation.

Make sure that the maintenance areas are accessible. If these areas have to be invaded by the lateral air supply and/or return ducts, verify that the design of the ducts allows the access to the fans and that they are not a hindrance when replacing the filters. If that is not possible make sure access is possible from the other side.

**All operations shall be carried out in accordance with the local safety regulations.**

## Repairing Operations



The reparations shall always and exclusively be completed by trained personnel previously authorized by the manufacturer and only original spares shall be used. The safety devices of the unit may be damaged in case of non-compliance with these warnings.

## Modifications

The manufacturer will not respond to possible warranty claims and damages of the unit in case of electrical and/or mechanical modifications. The unauthorized manipulation, reparation or modification of the unit will automatically invalidate the warranty.

## Packaging and Replacement of Equipment



The material of the package (plastic bags, insulating materials, nails, etc.) is a potential source of danger. Consequently, it should be kept out of the reach of children and properly recycled according to the valid local safety regulations.

Do not mix this product with household waste at the end of its life. Due to the refrigerant, oil and other components contained in this product, it must be dismantled by professional installers. All the waste, depending on its nature shall be sent to recycling, composting or treatment plants, or to an authorized management agency in accordance with the current local legislations.

## Refrigerant

This product is hermetically sealed and its operation depends on the use of R-410A which is a HFC fluorinated greenhouse gas.

# REGULATIONS AND CERTIFICATIONS

**ISO 9001 CERTIFICATION:** BAXI, by endeavouring to always gain the maximum satisfaction from their customers, obtained the ISO 9001: Quality System for its production activity. That result shows our continuous determination to improve quality and the reliability of all our products. Our commercial activities, design, raw materials, production processes and after-sales service represent the means to reach our goal.

**CE MARKING:** Our products are CE marked according to the essential requirements of the applicable EC directives and their last modifications and comply with the national legislation of each country.



# REGULATIONS AND CERTIFICATIONS

Please go to the website for the Declaration of Conformity:  
<https://declaration-of-conformity.bdrthermeagroup.com>



## SAFETY INSTRUCTIONS



### WARNING

Before starting any installation, service or maintenance operation, turn the main power switch off in order to avoid electrical discharges that may cause personal injuries.



### DANGER

- Should it be necessary to open the electrical box in order to get inside the equipment, it is **COMPULSORY** to plug the main power cable out prior to this operation. The equipment **MUST ALWAYS BE FREE OF VOLTAGE** when opening the electrical box.
- Do not touch or adjust the safety devices inside the unit. For repairs use only original spare parts and install them properly in the same position where the old parts were fitted.
- The installation and maintenance of air conditioning equipment may be dangerous due to the pressure of the system, the high temperature of some of its parts and the electrical components.
- Do not install the unit in an explosive atmosphere.



### ATTENTION!

- Only qualified and trained service staff (technical service) is authorized to carry out installation, commissioning and maintenance. Unqualified personnel will carry out basic tasks only such as cleaning and replacement of filters, or filter cleaning (excluding the refrigerant filters), etc....
- Prevent access to children to avoid that they play with the equipment.
- For all visits, follow carefully all recommended precautions: the instructions recommended in the installation, operation and maintenance manual, as well as the precautions stated on the stickers placed on the unit. Do not forget to strictly follow any other legal safety instructions.
- DO NOT introduce objects into the air inlets or outlets that might be drawn into the fan, people, etc.
- Use safety glasses, work gloves and any other safety accessory that may be necessary for the operation.
- For brazing operations use a quenching cloth and make sure you have a fire extinguisher close to you.
- This product contains fluorinated greenhouse gases. In case of leakage air may be displaced which may cause lack of oxygen.
- This manual should only provide basic instructions for operations that can be performed on the equipment by a normal user (a person without specific training, children over 8 years of age, etc.).
- This equipment can be used by children over 8 years of age and persons with reduced physical, sensory or mental capabilities or lack of experience and knowledge, provided they are supervised or have been given instructions on how to use the equipment safely and understand the risks to which they are exposed.
- Do not pierce or burn.
- Please note that refrigerants may be odourless.
- Machine not accessible to the general public.
- **Please follow all the safety recommendations carefully.**

# TECHNICAL SPECIFICATIONS

## UMXCBA / UMXCA

MODELS		801.1	1001.1	1201.1	1501.1
<b>COOLING CAPACITY</b>					
Nominal cooling capacity <sup>(1)</sup>	kW	25,9	31,2	38,1	42,9
Total absorbed power cooling <sup>(1)</sup>	kW	8,8	9,8	12,5	14,3
EER coefficient cooling	---	2,94	3,19	3,05	3,01
<b>HEATING CAPACITY</b>					
Nominal heating capacity <sup>(2)</sup>	kW	27,3	30,7	39,5	43,6
Total absorbed power heating <sup>(2)</sup>	kW	7,1	8,4	10,9	11,4
COP coefficient	---	3,85	3,67	3,63	3,82
<b>REFRIGERANT</b>					
Type	---	R-410A			
Charge <sup>(3)</sup>	kg	6,5	7	8	8,3
Global warming potential (GWP) <sup>(4)</sup>	---	2088			
<b>ELECTRICAL SPECIFICATIONS</b>					
Power supply	V / ~ / Hz	400 / 3+N / 50			
Maximum absorbed current	A	27,9	29,9	38,6	44,9
Start current	A	145,4	145,4	162,2	201,3
<b>COMPRESSOR</b>					
Type	---	Scroll			
Number	---	1			
Number of refrigerant circuit	---	1			
Number of stages	---	1			
Oil type		Danfoss POE oil 160SZ			
Oil volume	L	3,3	3,3	3,3	3,6
<b>REFRIGERANT CONNECTIONS</b>					
Liquid line diameter circuit 1	"	5/8			
Gas line diameter circuit 1	"	1 1/8			
Liquid line diameter circuit 2	"	-	-	-	-
Gas line diameter circuit 2	"	-	-	-	-
<b>FAN</b>					
Type	---	Outdoor Axial Rotor			
Nominal air flow	m <sup>3</sup> /h	17700	17700	19700	19700
Available static pressure	Pa	0			
Number	---	1			
Diameter	mm	710	710	800	800
Power Δ/Y	kW	1,25 / 0,97	1,25 / 0,97	1,90 / 1,20	1,90 / 1,20
Speed Δ/Y	r.p.m.	950 / 825	950 / 825	890 / 690	890 / 690
<b>DIMENSIONS AND WEIGHT</b>					
Length	mm	1200	1200	1200	1200
Width	mm	1050	1050	1050	1050
Height	mm	1470	1470	1470	1470
Weight	kg	256	277	283	287

(1) Calculated according to the UNE-EN-14511 standard, for indoor temperature conditions of 27°C B.S. / 19°C B.H. and 35°C outdoor temperature.

(2) Calculated according to the UNE-EN-14511 standard for indoor temperature levels lower than 20°C and outdoor temperature levels of 7°C B.S. / 6°C B.H.

(3) The unit is delivered with a pre-charge of refrigerant and with a quick connection valve. Remember to add the needed charge according to the length of the installation.

(4) GWP: Global warming potential (climatic) of 1 kg of greenhouse gas relative to 1 kg of CO<sub>2</sub>, calculated over a period of 100 years.

# TECHNICAL SPECIFICATIONS

## UMXCBA / UMXCA

MODELS		1602.2	2002.2	2402.2	3002.2
<b>COOLING CAPACITY</b>					
Nominal cooling capacity <sup>(1)</sup>	kW	50,4	62,8	74	85
Total absorbed power cooling <sup>(1)</sup>	kW	17,4	19	24,4	28,2
EER coefficient cooling	---	2,9	3,3	3,03	3,02
<b>HEATING CAPACITY</b>					
Nominal heating capacity <sup>(2)</sup>	kW	53,2	61,8	76,6	86,7
Total absorbed power heating <sup>(2)</sup>	kW	15	17,4	22,8	24,3
COP coefficient	---	3,55	3,54	3,36	3,57
<b>REFRIGERANT</b>					
Type	---	R-410A			
Charge <sup>(3)</sup>	kg	2 x 6,5	2 x 7,0	2 x 8,0	2 x 8,3
Global warming potential (GWP) <sup>(4)</sup>	---	2088			
<b>ELECTRICAL SPECIFICATIONS</b>					
Power supply	V / ~ / Hz	400 / 3+N / 50			
Maximum absorbed current	A	55,6	61,2	76,8	88,7
Start current	A	171,0	173,0	197,6	241,6
<b>COMPRESOR</b>					
Type	---	Scroll			
Number	---	2			
Number of refrigerant circuit	---	2			
Number of stages	---	2			
Oil type		Danfoss POE oil 160SZ			
Oil volume	(l)	2 x 3,3	2 x 3,3	2 x 3,3	2 x 3,6
<b>REFRIGERANT CONNECTIONS</b>					
Liquid line diameter circuit 1	"	5/8			
Gas line diameter circuit 1	"	1 1/8			
Liquid line diameter circuit 2	"	5/8			
Gas line diameter circuit 2	"	1 1/8			
<b>FAN</b>					
Type	---	Outdoor Axial Rotor			
Nominal air flow	m <sup>3</sup> /h	35400	35400	39400	39400
Available static pressure	Pa	0			
Number	---	2			
Diameter	mm	710	710	800	800
Power Δ/Y	kW	1,25 / 0,97	1,25 / 0,97	1,90 / 1,20	1,90 / 1,20
Speed Δ/Y	r.p.m.	950 / 825	950 / 825	890 / 690	890 / 690
<b>DIMENSIONS AND WEIGHT</b>					
Length	mm	2215	2215	2215	2215
Width	mm	1350	1350	1350	1350
Height	mm	1510	1510	1510	1510
Weight	kg	506	549	560	568

(1) Calculated according to the UNE-EN-14511 standard, for indoor temperature conditions of 27°C B.S. / 19°C B.H. and 35°C outdoor temperature.

(2) Calculated according to the UNE-EN-14511 standard for indoor temperature levels lower than 20°C and outdoor temperature levels of 7°C B.S. / 6°C B.H.

(3) The unit is delivered with a pre-charge of refrigerant and with a quick connection valve. Remember to add the needed charge according to the length of the installation.

(4) GWP: Global warming potential (climatic) of 1 kg of greenhouse gas relative to 1 kg of CO<sub>2</sub>, calculated over a period of 100 years.

# TECHNICAL SPECIFICATIONS

## UMXCBA / UMXCA

MODELS		3502.2	4002.2	4502.2
<b>COOLING CAPACITY</b>				
Nominal cooling capacity <sup>(1)</sup>	kW	108.8	123,9	134,7
Total absorbed power cooling <sup>(1)</sup>	kW	52.4	40,3	44,7
EER coefficient cooling	---	3,05	3,07	3,01
<b>HEATING CAPACITY</b>				
Nominal heating capacity <sup>(2)</sup>	kW	118,2	131	142,4
Total absorbed power heating <sup>(2)</sup>	kW	32,5	36,8	40,8
COP coefficient	---	3,63	3,57	3,49
<b>REFRIGERANT</b>				
Type	---	R-410A		
Charge <sup>(3)</sup>	kg	2 x 14	14 + 15,5	2 x 15,5
Global warming potential (GWP) <sup>(4)</sup>	---	2088		
<b>ELECTRICAL SPECIFICATIONS</b>				
Power supply	V / ~ / Hz	400 / 3+N / 50		
Maximum absorbed current	A	114,7	128,5	135,5
Start current	A	272,6	286,4	331,4
<b>COMPRESSOR</b>				
Type	---	Scroll		
Number	---	2		
Number of refrigerant circuit	---	2		
Number of stages	---	2		
Oil type		Danfoss POE oil 160SZ		
Oil volume	(l)	2 x 6,7	2 x 6,7	2 x 6,7
<b>REFRIGERANT CONNECTIONS</b>				
Liquid line diameter circuit 1	"	7/8		
Gas line diameter circuit 1	"	1 3/8		
Liquid line diameter circuit 2	"	7/8		
Gas line diameter circuit 2	"	1 3/8		
<b>FAN</b>				
Type	---	Outdoor Axial Rotor		
Nominal air flow	m <sup>3</sup> /h	46400	65900	65900
Available static pressure	Pa	0		
Number	---	2	4	4
Diameter	mm	800	710	710
Power Δ/Y	kW	1,90 / 1,20	1,25 / 0,97	1,25 / 0,97
Speed Δ/Y	r.p.m.	890 / 690	950 / 825	950 / 825
<b>DIMENSIONS AND WEIGHT</b>				
Length	mm	2215	2215	2215
Width	mm	1960	1960	1960
Height	mm	2170	2170	2170
Weight	kg	979	1043	1046

(1) Calculated according to the UNE-EN-14511 standard, for indoor temperature conditions of 27°C B.S. / 19°C B.H. and 35°C outdoor temperature.

(2) Calculated according to the UNE-EN-14511 standard for indoor temperature levels lower than 20°C and outdoor temperature levels of 7°C B.S. / 6°C B.H.

(3) The unit is delivered with a pre-charge of refrigerant and with a quick connection valve. Remember to add the needed charge according to the length of the installation.

(4) GWP: Global warming potential (climatic) of 1 kg of greenhouse gas relative to 1 kg of CO<sub>2</sub>, calculated over a period of 100 years.

## TRANSPORT INSPECTION AT RECEPTION

- It is advisable to examine the equipment carefully upon reception.
- Check that the equipment has not been damaged during transport and that it is complete with all the parts specified in the order and/or the options stated in the order. If this is not the case please contact the transport company immediately (within 48h).
- Verify the correct voltage of the nameplate and make sure it is in accordance with local power supply.
- In case of any flaw or anomaly detected, please contact BAXI.

## RIGGING

- Before moving the unit, make sure that all panels are fixed properly.
- Raise and put the equipment down carefully.
- Do not tilt the unit more than 15 degrees during transportation.
- Always transport the unit in its original packaging to the place of installation.
- All units come with a particular rigging diagram of that model similar to the one shown below. Be sure to hoist the machine through the points indicated in the diagram.
- Make sure that the unit is balanced, stable and without any deformations during the lifting operations.

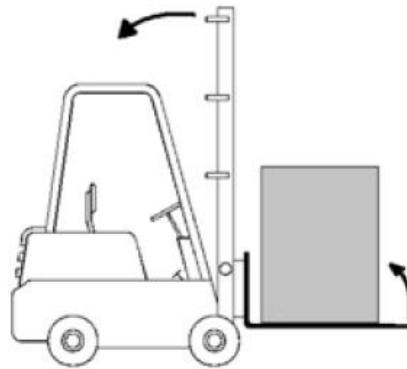
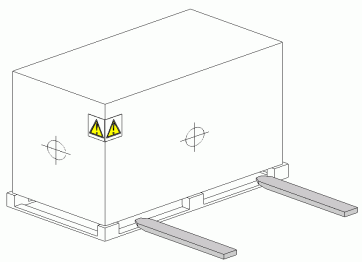

## STORAGE

If the equipment is going to be stored before the installation, please follow the following instructions in order to avoid damages, corrosion or deterioration:

- Move the equipment carefully.
- Do not place the unit in places exposed to ambient temperatures above 50°C and preferably keep the unit away from direct sunlight.
- Avoid placing the unit with plastic wrapping protection under the sun as the pressure of the circuits could reach values that could lead to the activation of the safety valves.  
Moreover, with decreasing temperatures water condensation may occur inside the machine and the plastic wrap.
- Avoid placing other objects on top of the unit (unless this is done within the limits of the overlap planes indicated on the packaging, etc. Follow these indications).
- Avoid prolonged storage before installation, water penetration, dust and objects in general due to invasion or biological, meteorological and/or human impacts.
- Minimum storage temperature: -10°C
- Maximum relative humidity: 90%.

# INSTALLATION

## INSTALLATION SITE

- Read and comply with the local rules and regulations applying to the installation of air conditioning systems.
- Choose a clean place without dust nor debris.
- Remain within the appropriate service area of the equipment.
- Verify that the ground or the structure prepared for the equipment is strong enough to support its weight during operation.
- Install shock absorbers throughout the installation to prevent the transmission of noise and vibration.
- Check that the direction of the sound level will not disturb anybody.
- The standard version of this equipment has been designed for installation inside a building (with a roof). Please check with BAXI if you plan to expose the machine to weather conditions.
- This equipment is not suitable for exposition to weather conditions. Please contact BAXI if you plan to install it outside.

## UNIT SETTLEMENT

- Make sure that the equipment is levelled correctly.
- The bed frame shall be strong enough to support the unit weight.
- Verify that the drains are working properly.
- Use shock-absorbers and fit them as indicated.

## SERVICE AREA

Make sure that you respect the following dimensions to ensure that the equipment works properly.

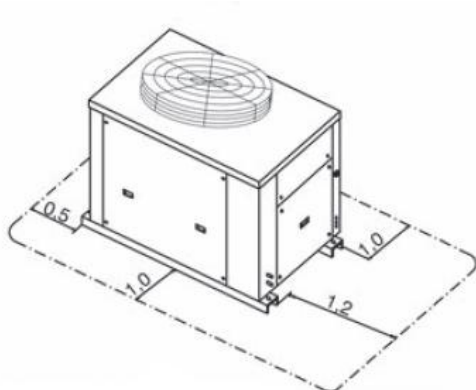

UMXCA, UMXCBA 801 - 1501

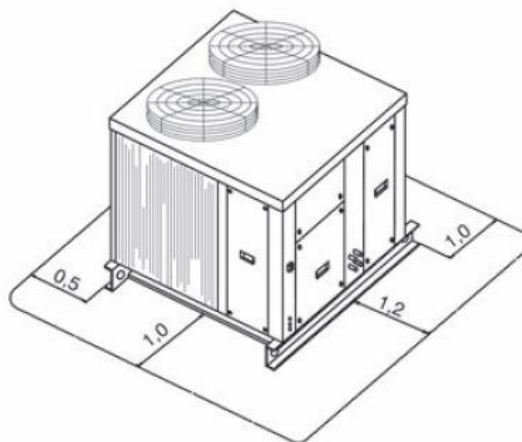

UMXCA, UMXCBA 1602 - 3002

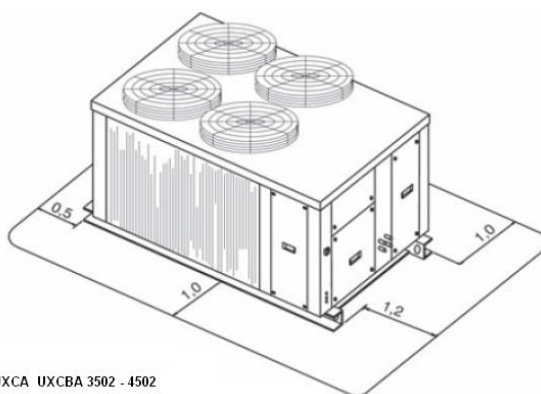

UXCA UXCBA 3502 - 4502

## INSTALLATION

### WEIGHT DISTRIBUTION (KG)

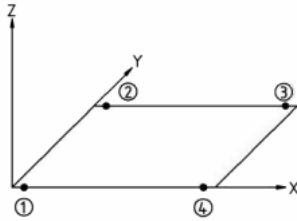

MODELS	1	2	3	4	TOTAL
801.1	76	60	53	67	256
1001.1	82	65	58	73	277
1201.1	80	69	62	72	283
1501.1	82	69	62	74	287
1602.2	113	102	161	130	506
2002.2	124	116	172	137	549
2402.2	128	119	174	139	560
3002.2	129	120	177	149	568
3502.2	226	225	224	229	904
4002.2	239	238	237	242	956
4502.2	240	239	238	243	960

### WATER DRAIN

- All the drains are provided with a 3/4" male gas connection.
- The diameter of the condensate drain pipe shall be equal or larger than the unit connection depending on the line length and the building configuration.
- The drainage line shall have a slope of not less than 2% to guarantee the correct evacuation of the condensate water.
- When the drain line is exposed to air temperatures below 0 degrees, thermal insulation or electrical heating wires shall be used to prevent the water from freezing and avoid the possible following tube damages.
- Install a siphon with the appropriate dimensions (refer to drawing).

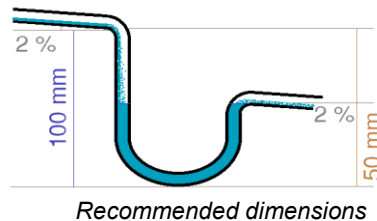

### AIR DUCTS

- The air duct dimensions will be determined according to the air flow and the available static pressure of the unit.
- They shall be designed by qualified technicians. An incorrect design may reduce the unit's performance and may be a hindrance when access to the unit for maintenance operations is needed (in particular where there is only one possible access).
- Use ducts made of non-inflammable material in order to avoid any risk of fire as a consequence of the deflagration of gases. It is advisable to use insulated metal ducts.
- Use flexible conduits to connect air ducts to the unit so as to avoid vibration and noise transmission.
- The following shall be taken into account regarding the units that include several circuits with separate ventilation systems and where there is the possibility that the fan of one circuit stops while the other one remains active:  
Install separate air ducts for each circuit TO AVOID reverse air flow.

# INSTALLATION

## REFRIGERANT LINES

For more information about the refrigerant line, please request the ref. 207682 document.

### Refrigerant circuit

It is extremely important to design the refrigerant lines correctly between the indoor and the outdoor units. The following criteria shall be taken into account when completing that task:

- The line pressure drop.
- The refrigerant circulation speed.
- The refrigerant mass in the system.
- The length of the interconnection pipes (please contact BAXI for lines longer than 50 meters).

### Discharge lines

In the heating mode: the suction line becomes the discharge line.



**ATTENTION!**

Handling when the unit is working: the discharge line temperature is HIGH, beware of burning risks!

### LINE DESIGN

- *Only Cooling Units / Heat Pump Units*

The indoor unit is placed at a lower level than the outdoor unit: siphons are not necessary in the vertical section (However we recommend to include one every 6 to 9 meters in order to make the oil return quicker for start-ups).

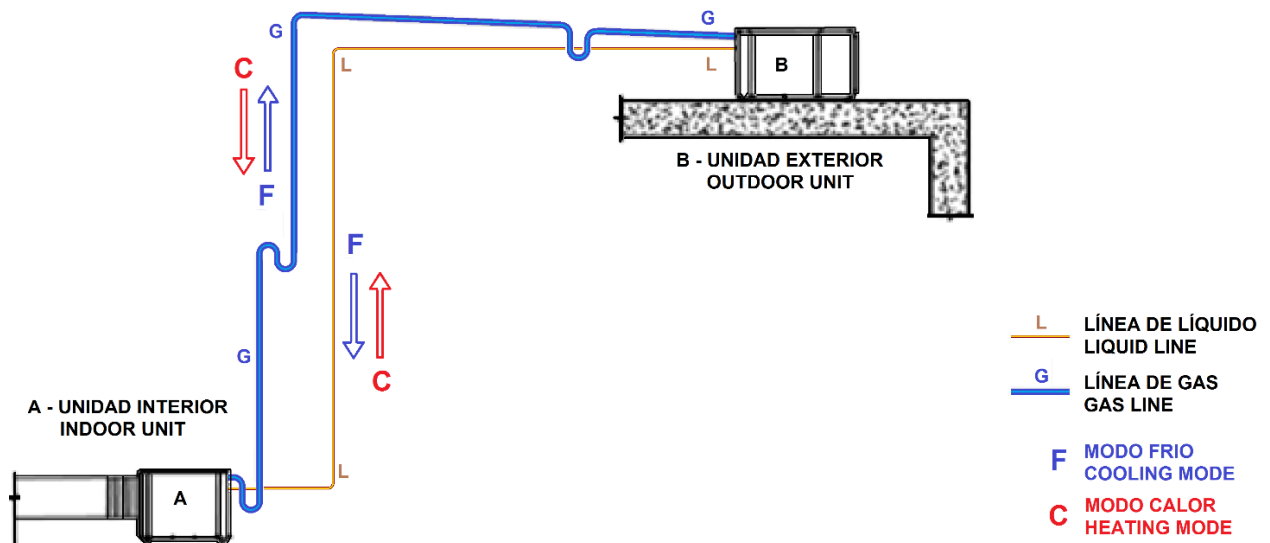

# INSTALLATION

## REFRIGERANT LINES

### LINE DRAWING

Cooling only units / heat pumps

The indoor unit is installed at the same level as the outdoor unit: raise the suction line to a higher level than the indoor heat exchanger in order to avoid refrigerant return into the compressor during stops that would produce liquid hammering.

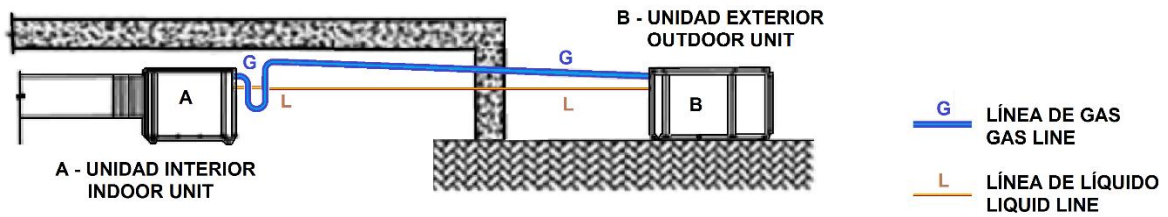

The indoor unit is placed at a higher level than the outdoor unit: raise the suction line to a higher level than the indoor heat exchanger level.

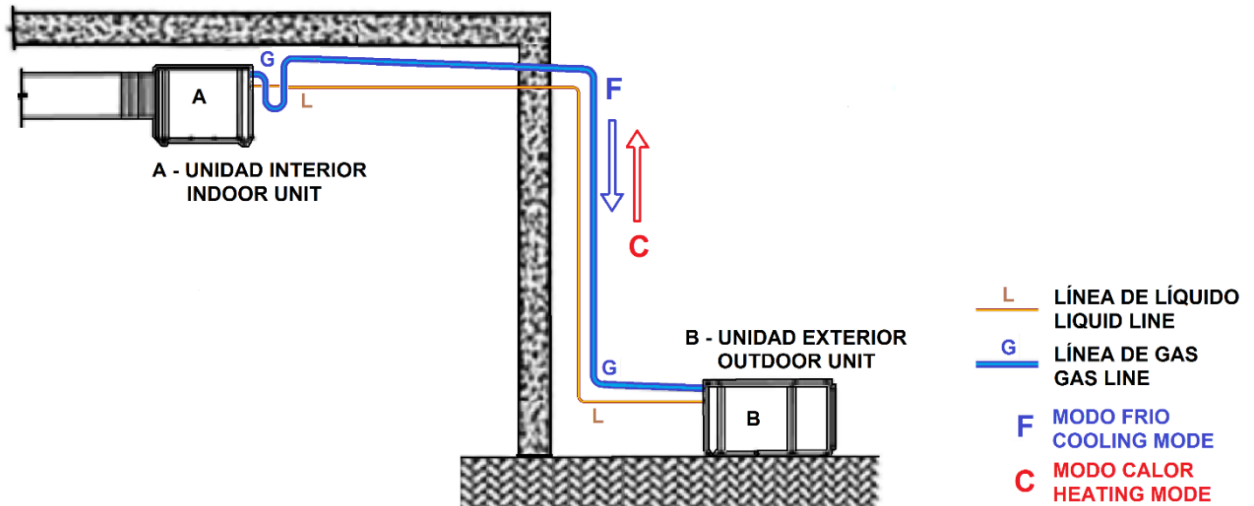

# INSTALLATION

## REFRIGERANT LINES

### Additional load in the interconnection pipes

Pipe	ADDITIONAL LOAD in the interconnecting pipes according to the pipe diameters and the real length (m)													
	Grams per metre		5		10		20		30		40		50	
	GAS (g/m)	LIQ. (g/m)	GAS (g)	LIQ. (kg)	GAS (g)	LIQ. (kg)	GAS (g)	LIQ. (kg)	GAS (g)	LIQ. (kg)	GAS (g)	LIQ. (kg)	GAS (g)	LIQ. (kg)
3/16"	0	9	1	0,04	2	0,09	5	0,17	7	0,26	10	0,34	12	0,43
1/4 "	1	18	3	0,09	5	0,18	10	0,37	15	0,55	21	0,73	26	0,91
5/16"	1	33	5	0,16	9	0,33	18	0,65	28	0,98	37	1,30	46	1,63
3/8 "	1	51	7	0,25	14	0,51	29	1,02	43	1,53	58	2,04	72	2,55
1/2 "	3	100	14	0,50	28	1,00	56	2,00	85	3,0	113	4,0	141	5,0
5/8 "	5	165	23	0,83	47	1,65	93	3,3	140	4,9	187	6,6	233	8,7
3/4 "	7	236	33	1,18	67	2,36	133	4,7	200	7,1	266	9,4	333	11,8
7/8 "	9	332	47	1,66	94	3,3	187	6,6	281	9,9	375	13,3	468	16,6
1 "	13	444	63	2,22	125	4,4	251	8,9	376	13,3	501	17,8	627	22,2
1 1/8"	16	573	81	2,86	162	5,7	323	11,5	485	17,2	647	22,9	808	28,6
1 3/8"	24	853	120	4,3	241	8,5	481	17,1	722	25,6	963	34,1	1204	42,6
1 5/8"	34	1219	172	6,1	344	12,2	688	24,4	1033	36,6	1377	48,8	1721	60,9
2 1/8"	61	2149	303	10,7	607	21,5	1213	43,0	1820	64,5	2427	85,9	3033	107,4
2 5/8"	92	3257	460	16,3	920	32,6	1839	65,1	2759	97,7	3678	130,3	4598	163,0
3 1/8"	132	4693	662	23,5	1325	46,9	2650	93,9	3975	140,8	5300	187,7	6625	234,7
3 5/8"	174	6148	868	30,7	1736	61,5	3472	123,0	5208	184,5	6943	245,9	8679	307,4
4 1/8"	225	7979	1126	39,9	2253	79,8	4505	159,6	6758	239,4	9011	319,2	11264	398,9

Example: Unit with liquid and gas pipes of 10 m real length each. The nameplate of the unit states a base load of 9 kg of the R410A refrigerant. The installed liquid line is of 3/4", the chart states **2,36 kg**. The gas line is of 1 3/8" and the table states **241 g=0,241 kg**, therefore we calculate that the total quantity to be loaded is:  $9 + 2,36 + 0,24 = 11,6 \text{ kg}$  of R410A.

The same result can be obtained by using the gram information per meter of the gas and liquid pipes stated in the chart:  $(236+24)$  and multiplying by the meters (10 m):  $236*10 + 24*10 = 2600 \text{ g} = 2,6\text{kg}$ . We will calculate again the total value by adding this value to the base load:  $9 + 2,6 = 11,6 \text{ kg}$ .

# INSTALLATION

## REFRIGERATION CONNECTIONS

***Damages caused by a wrong installation of the refrigeration connections between the indoor and the outdoor units will not be covered by the warranty.***

A wrong installation may entail the following sources of problems:

- Penetration of air, water or any type of object or animal.
- Pipes that are too thick or too thin.
- Strangled or poorly brazed tubes.
- Not complying with the current local laws because of a wrong layout and problems of aestheticism of the façades, etc.

Likewise, the above mentioned consequences may have an impact on:

- Speed of the refrigerant inside the pipe (too high or too low).
- Migration and no return of the compressor oil.
- Noises.
- Explosive breaks of the pipes.
- Contamination due to refrigerant leakage (greenhouse gas).
- Break of the solenoid valves or the expansion valves.
- Increased electrical consumption and decreased performance and capacity.
- Decreased operation limits. The unit might even become completely inoperative.
- Breakage of the compressor or shortening of its operation lifetime.

### Guidelines for the correct installation of the refrigeration connections

1. Select a suitable place and prepare the correct settlement of the units. Determine the length of the refrigeration lines between the units.
2. Calculate the dimensions of the pipes (diameters, lengths) and the necessary couplings for the installation. Use as a reference the n° 207682 document (REFRIGERATION LINES DESIGN (R410a)).
3. Before starting installation, control that the inside part of the tubes are clean and humidity proof. Use preferably long radius curves, do not produce throttles when handling the tube.

#### 4. Pipe installation:

- Cut the tube with a tubing cutter and then remove the burr and recalibrate the diameter that has been reduced. Recalibrate with interior gauge or tube expander. Do not use file, knife, or any other non-specialized tool that could leave particles inside the pipe.
- Reduce the number of brazing and remember that it should always be of the strong type. In compliance with local laws, the welder must be an authorized person. A bad weld can cause dirt inside the pipe, more or less explosive blowouts that may cause third-party damage, pipe obstruction, refrigerant leakage, etc. Remember that the tubes to be brazed must be clean without oil and refrigerant. Do not forget to make dry nitrogen circulate in the interior without pressurizing and heat the male pipe primarily to ensure a good penetration.

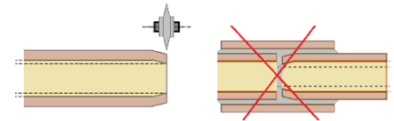

5. The connection of the pipes to the machines can be threaded or brazed. Check the tightness after the connections.

6. The most common threaded connections in small pipes are the Flare type (flared) connections. A bad Flare connection will entail leaks and/or blowouts. When doing the flare, it is essential to clean the burr of the tube properly to avoid cracks, and do not leave the pipe wall very thin and without consistency by tightening too much.

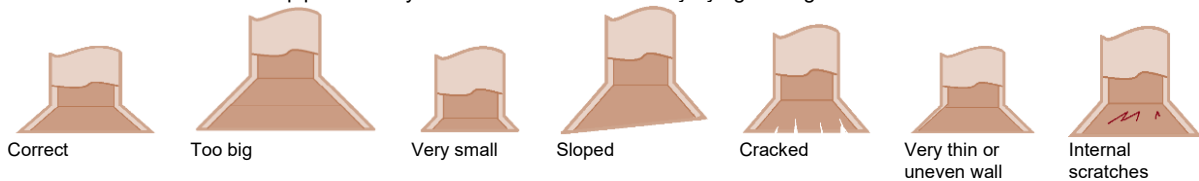

7. Make the vacuum to the installation and the units that are not charged with refrigerant. Once the vacuum pump stops, check that the vacuum remains during 20 min., a proper vacuum will be at an absolute pressure of 2 hPa (2 mbar) or less.

Humidity or water in the installation may cause irreversible damages to the compressor and other devices of the circuit. Liquid water cools and boils when the vacuum reaches its vapor pressure and does not allow it to do so correctly until it freezes, once the water is frozen it does not boil but it is much more difficult to remove and detect. To avoid the freezing of the water, it is advisable to make a soft and prolonged vacuum and not make a fast vacuum with very powerful pumps.

8. Open all the keys and load with the refrigerant indicated on the nameplate. If it is not included in the machine, add the additional load due to the length and thickness of the pipes. Follow current legislation regarding who and how can handle the refrigerant.

9. Check for leaks during the first operation hours and schedule maintenance after the first month.

## ELECTRICAL INSTALLATION



**WARNING!**

Turn the main power switch off before starting any type of operation.

- The unit power supply shall be within the 10% of voltage value indicated on the unit nameplate. The BAXI warranty will not cover any damage caused by the start-up of the unit with an incorrect voltage.
- Always refer to the unit wiring diagram when completing electrical connections.
- The electrical wiring connections and the line protection devices must be installed by the installer according to the current local laws.
- The interconnecting wires shall be protected by a tube or an electrical cable conduit, cable tray, etc.
- Use a suitable cable: power cables for outdoor use must not be lighter than flexible polychloroprene-coated cable (designation 60245 IEC 57).

## ELECTRICAL DIAGRAM

For further details please refer to the electrical wiring diagrams.

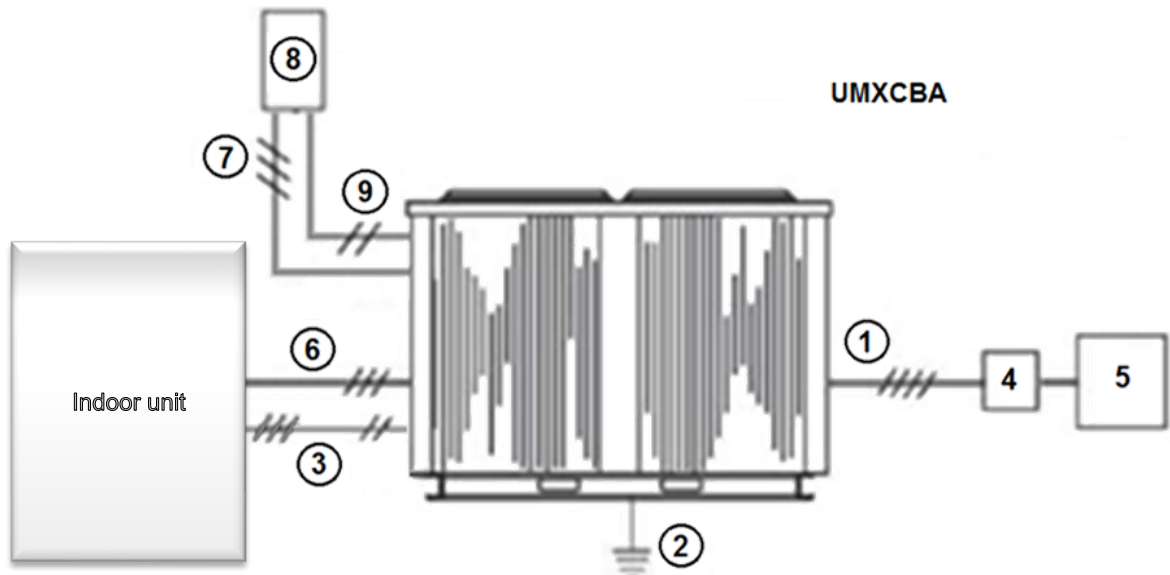

Th-TUNE control (Mini-pGD or pGD1 available as options)

### Legend:

1. Power supply 400V/3/50 + neutral
2. Earth
3. Optional inlet for electrical resistance control 2 or 3 cables (Common + 1 or 2 stages)
4. Time delay fuses or D curve circuit breaker.
5. Main power switch
6. Available power supply for indoor unit 400V.3
7. Communication cable: Twisted and shielded pair with drain wire.
8. Remote TH TUNE terminal
9. Power cable for TH TUNE, 230V/1

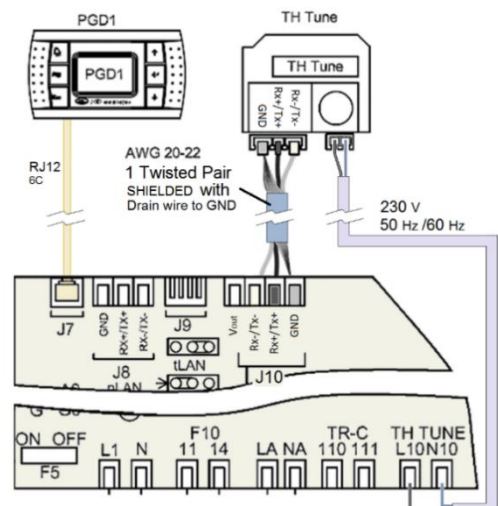

# INSTALLATION ELECTRICAL DIAGRAM pGD1 or Mini-pGD control

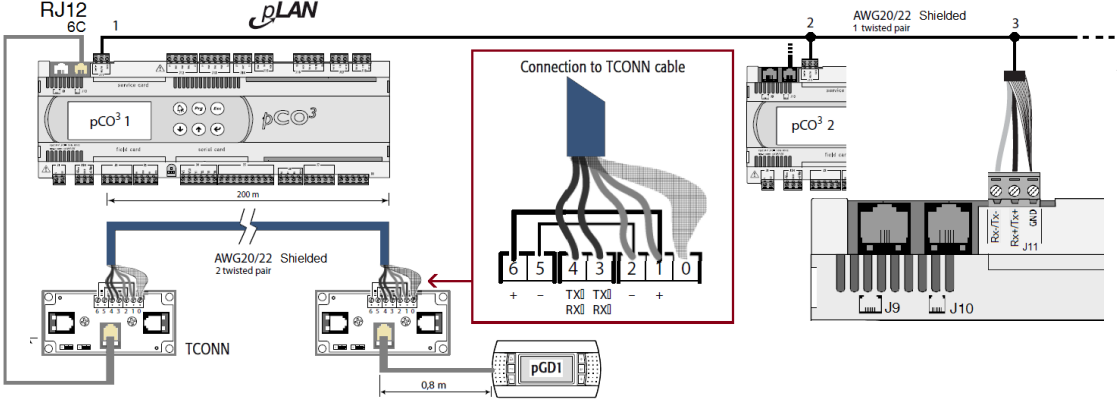

Connection to pGD1 via 6-wire telephone cable, for lines longer than 50m intercalate with TCONN (4 wires twisted and shielded, see diagram).

# OPERATION



## BEFORE START-UP

- Start-up has to be performed by a qualified service personnel in air conditioning.
- Make sure that the panels are firmly secured with screws.
- Check that there is no leakage of oil or refrigerant.
- Ensure that the unit is evenly leveled.
- Check if there is enough space for operation and maintenance.



**Before opening the electrical panel and having access to the interior of the unit it is COMPULSORY to disconnect the power supply cable of the machine which MUST BE FREE OF VOLTAGE for this operation.**

- Check that the drainage is not blocked.
- Always use the electrical diagram of the unit to make the connections.
- Make sure that all electrical connections are properly tight.
- The power supply of the unit must comply with the data stated on the serial plate. Damage caused by the start-up of the unit with an incorrect voltage line will not covered by BAXI's warranty.
- The unit must not be supplied with any other voltage than that indicated on the serial plate. The power supply to the unit must be within 10% of the voltage indicated on the serial plate.
- Check the correct rotation direction of the fans.
- The installer must place line protection parts according to the current legislation.
- The electrical wires must be protected by a tube or other cable conduits.
- Make sure that the crankcase heater of each compressor has been operating for 24 hours prior the Start Up.
- Check that the air filters are clean and fitted correctly.
- Check the condition and position of the grilles, diffusers, air ducts, tarpaulins, etc...

# OPERATION

## START UP

- Register the air inlet and outlet temperatures to the internal coil, the volts and amps of the compressor and motor fan, as well as the suction and discharge pressure of each compressor.
- Remember to clean the air filters after the first 4 hours of operation.
- Observe, at least, 3 cooling cycle operations.
- Since the unit is equipped with frequency converters it is essential that the protection is at least 300mA to prevent power cuts caused by the activation of the circuit breaker.

## INDOOR FAN TRANSMISSION ADJUSTMENT

- Adjust transmission so that the indoor motor consumption reaches its normal value.
- If consumption is below the nominal value it means that the unit air flow is too low.

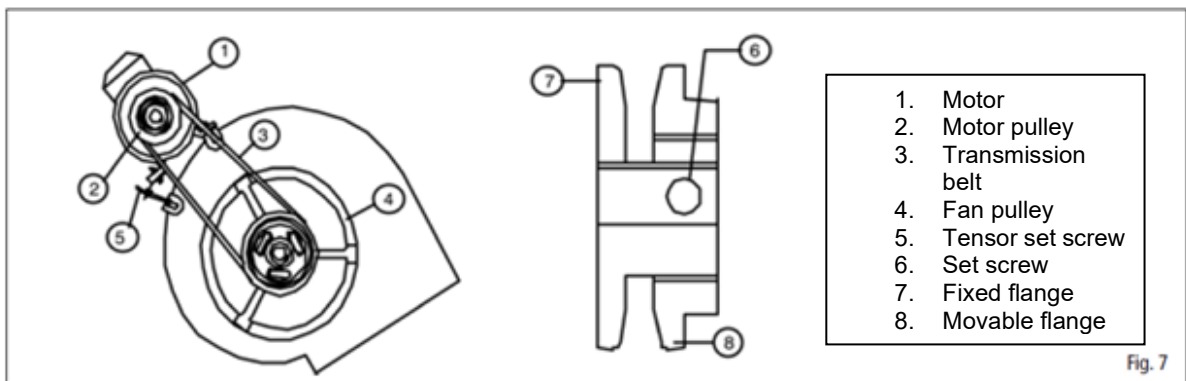

### - How to change the fan speed:

1. Remove the belt. Move the motor along its track (or loosen the tensor set screw) in order to release it.
2. Loosen the set screws of the motor pulley and turn the movable flange. Open or close depending on the needs (Open: speed decreases).
3. Tighten set screws.
4. Place the belt in the pulley channel. The closure or opening of the pulley could void the size of the prior belt. In this case, replace it for other belt of the same profile and with the appropriate length.
5. Tighten the belt by using a tensor screw or by sliding the motor, depending on the case.

### - Align fan and motor pulleys:

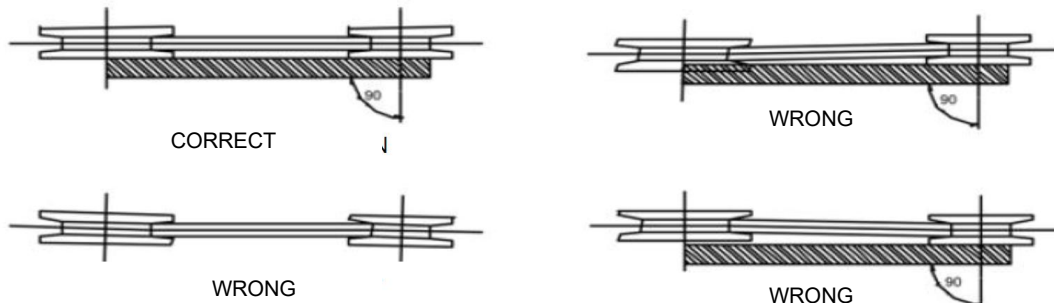

1. Loosen the fan pulley set screws.
2. Slide the fan pulley along the shaft and align it with the motor by using a ruler in order to ensure that it is parallel to the belt.
3. Tighten the fan pulley set screws.

## OPERATION

### INDOOR FAN TRANSMISSION ADJUSTMENT

**- Adjust the belt tension:**

1. Loose the motor's mounting plate bolt and slide it.
2. The belt flexibility is calculated in millimeters by dividing S by 40.

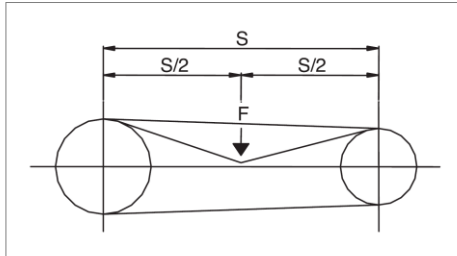

S(mm) +/- 2	F (mm) +/- 1
200-250	5,0 - 6,2
250-300	6,2 - 7,5
300-325	7,5 - 8,1
325-350	8,1 - 8,7
350-375	8,7 - 9,4
375-400	9,4 - 10,0
400-425	10,0 - 10,6

S(mm) +/- 2	F (mm) +/- 1
425-450	10,6 - 11,2
450-475	11,2 - 11,8
475-500	11,8 - 12,5
500-525	12,5 - 13,1
525-550	13,1 - 13,7
550-650	13,7 - 16,2
650-750	16,2 - 18,7

## OPERATION LIMITS

	OUTDOOR AIR TEMPERATURE
	Dry temperature
COOLING CYCLE	°C
Minimum conditions	20*
Maximum conditions	50
HEATING CYCLE	°C
Minimum conditions	-10
Maximum conditions	50

\*For temperatures below 20°C, the condensation control is necessary (available as an option).

These units can be running at a maximum altitude of 1500 m above sea level with a performance loss lower than 3%.

## OPERATION

### TH-TUNE CONTROL

#### Display:

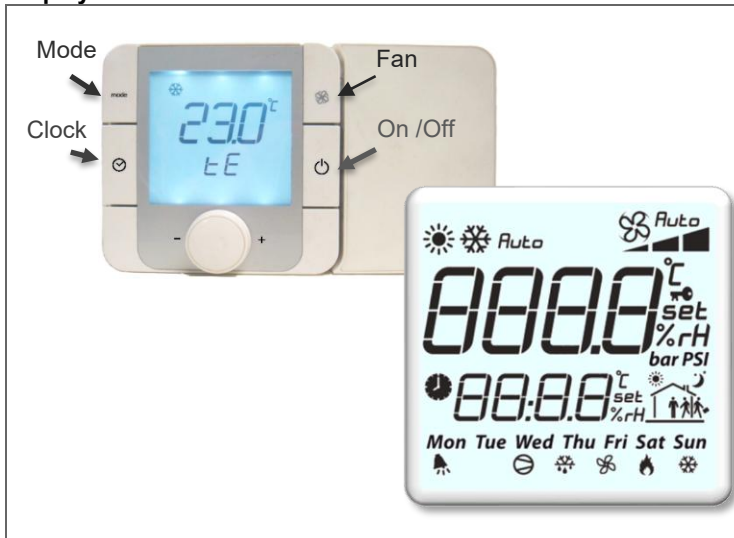

- LCD backlighted display.
- Two alphanumeric strings of 4 characters.
- Complete set of symbols to obtain all the information about the operation simultaneously on the same display.
- Central multifunctional button: turn it to go through the menus or increase/decrease a value and press it to introduce or select.

#### Start / Stop

Press and hold the (On / Off) button for two seconds to turn the thermostat on or off. The word "OFF" will be shown on the thermostat display when it is off.

**NOTE:** The thermostat will show "OFFd" when the remote On-Off contact is open and "OFFs" when switching off is requested through Modbus.

#### Setpoint Temperature Adjustment

- Adjust the SETPOINT temperature by turning the center button.

#### Calibration of the Th-Tune internal temperature probe

Use a correction value, positive or negative, that shall be added to the value of the probe. A value equal to zero will not change the value of the probe.

- Press keys FAN + ON/OFF and keep them pressed until a password is required.
- Enter password "22" and press for log in. Turn the central button until the option PCAL is displayed and select.

Turn the central button to modify the correction value and press for validation.

#### Operation modes

Press the (Mode) button to scroll through the available operation modes.

Available Operation Modes:

- **Cooling** – The display will show the icon ❄️
- **Heating** – The display will show the ☀️ icon. This icon will not be available for the Cooling Only units.
- **Auto** – The display will show "Auto". Not available for the Cooling Only units. The operating mode will change between cool and heat depending on the selected temperature Set-point. The currently active mode will be shown on the lower right corner of the thermostat: 🔥 ❄️.
- **Fan only** – The display will show the ❄️ + ☀️ icons at the same time. The fan will operate in a continuous mode and the registered temperature setpoint will not be taken into consideration. Only one speed is available.

# OPERATION

## TH-TUNE CONTROL

### Indoor Fan:

“Fan / Autofan” with “Continuous / Auto” ventilation

- Press the (Fan) button to toggle between automatic ventilation and continuous ventilation.

Available ventilation modes:



- With automatic fan – The Display icon will show "Auto".
- The fan works only when there is request for cool or heat.



- Without automatic fan – The word “Auto” will disappear from the icon.
- The fan works in a continuous mode.

### Programación horaria

- Keep the button pressed during 3 seconds minimum until “Clock” appears (if the stated hour is not correct you can change it here): turn the central button and chose “Time band” or select “Esc” to leave.
  - In general so as to move through the different displays, turn the central button and select by pressing it.

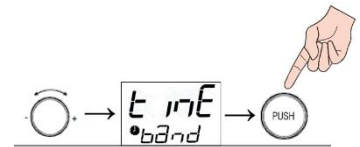

- Turn the central button to select the desired schedule type.
  - Select if you want a different schedule day by day, the same schedule for all week (displays all days) or one from Monday to Friday and other from Saturday to Sunday. Press the central button to select the desired day or days.
- By turning the button you can select 6 different displays that correspond to 6 different moments of the day (see displays):
  - A temperature set-point is set for each display if you want the unit to be operating or we program “OFF” if we want it to be stopped. We set the hour when it will be activated. If we select “--:--” instead of an hour, the display will be deprogrammed and it will not activate.
  - The hour that we can select for each display will always be greater than the hour of the previous display.
  - It is not possible to modify the operation mode.
  - Press ESC display to exit.
  - The icons on the display are meant as guide symbols only and the user can select the hours according to his personal needs.
  - After the last hour range (t6) is finalized the next one will start from t1 on the following day,

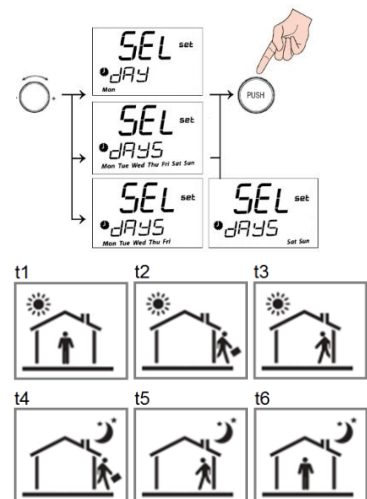

### Ejemplos de programación horaria:

#### Schedule for a continuous working day from 9:00am to 9:00pm

- t1: Start-up, “8:45”
- t2, t3: without scheduling, “--:--”
- t4: Stop, “20:00”
- t5, t6: without scheduling, “--:--”

#### Schedule for a split working day 9:00-13:00 and 16:00-20:00

- t1: Start-up, “8:45”
- t2: Stop due to midday break or setting down to a cheaper set point value “13:00”
- t3: Start-up or return to the normal “16:00”

- t4: Stop. End of working day “20:00”
- t5, t6: without scheduling, “--:--”

#### Household scheduling

- t1: Start up, “7:00”
- t2: Stop due to absence or setting down to a cheaper Setpoint value “8:30”
- t3: Start-up or return to the normal setpointing “13:15”.
- t4: Stop due to absence or setting down to a cheaper Setpoint value “15:30”
- t5: Start-up or return to the main Setpoint value.
- t6: Night stop or setting down to a cheaper setpoint “13:00”

# OPERATION

## TH-TUNE CONTROL

### Alarms

The unit will stop when any alarm is displayed with a code.

#### Resetting the Alarm Codes



Press several times the central button until RES is displayed (only available when there is at least one active alarm).

All the alarms whose causes have disappeared or have been solved, are canceled.



Turn the central button to go from 0 to 1.



Press the central button one time to confirm.

When the reset is completed, the text will change to OK.

After resetting, the thermostat will automatically return to the normal position and will display the room or return temperature depending on its configuration.

#### Alarm explanations:

#### TH TUNE – Description of the alarm codes

CODE	DESCRIPTION
AL01	Alarm probe B1 disconnected (Outdoor Temperature)
AL02	Alarm probe B2 disconnected (Air supply Temperature)
AL03	Alarm probe B3 disconnected (Comp. 1 discharge Temperature)
AL05	Alarm probe B5 disconnected (Return humidity)
AL06	Alarm probe B6 disconnected (Return humidity)
AL07	Alarm probe B7 disconnected (Outdoor humidity)
AL11	Alarm probe B11 disconnected (Low pressure C1, only units with 2 circuits)
AL12	Alarm probe B12 disconnected (Low pressure C2, only units with 2 circuits)
ALb1	Alarm probe B1 disconnected (Outdoor temperature)
ALb2	Alarm probe B2 disconnected (Air supply temperature)
ALb3	Alarm probe B3 disconnected (Comp. 1 discharge Temperature)
ALb5	Alarm probe B5 disconnected (Return humidity)
ALF6	Thermic alarm outdoor fan/compressor
ALF7	Thermic alarm indoor fan
	Thermic alarm outdoor fan 2 (2-circuit unit)
ALF8	Thermic alarm indoor fan (2-circuit unit)
ALPA	High pressure switch alarm circuit 1
ALPB	Low pressure switch alarm circuit 11
ALPM	Minimal pressure switch alarm
ALRF	Lack of refrigerant alarm
A2F7	Thermic alarm compressor 2 (2-circuit unit)
A2F8	Thermic alarm indoor fan 2 (2-circuit unit)
A2PA	High pressure switch alarm circuit 2
A2PB	Low pressure switch alarm circuit 2
A2PM	Minimal pressure switch alarm circuit 2
A2RF	Alarm lack of refrigerant circuit 2

# OPERATION

## PGD1 OR MINI PGD THERMOSTAT



Controller available as an option for Air-Air, Water-Air models and as a standard feature for the models equipped with accessories: Free Cooling, RCF and VRC, etc.

There are two different versions of the software depending on the models:

1. **HIT005 version** models with complements/ options that require that the pGD1 controller comes as a standard feature.
2. **HITSAA01 version** models that have Pgd1 or Mini PGD as an option.

The different menus and displays of the HIT005 version are organized with numbers (1, 2, 3...) while the HITSAA01 version has menus and displays organized by letters (A, B, C...).

### KEYBOARD



**ALARM KEY:** Press for display of the alarms on the screen. When the key is highlighted in red (only pGD control), there is one alarm on the unit.

**PROGRAM KEY:** Press to enter the general menu, the main menus are displayed.

**ESCAPE KEY:** Goes back one level in any submenu, help is shown on the main screen.

**UP KEY:** Scrolling through the menus or modification of the values of the regulation parameters.

**ENTER KEY:** Confirmation of the introduced values.

**DOWN KEY:** Scrolling through the menus or modification of the values of the regulation parameters.

To modify any value, enter the main menu by pressing the “Prg” key. Move through the menu by using the arrow keys and select the desired option by pressing the “Enter” key. Once the value is found, maintain the cursor on it and change the value by using the arrow keys. Confirm the new value by pressing “Enter”. Finally press “Esc” to leave.

### On / Off

From the main menu select START/STOP (On/Off unit) by pressing “Enter”. You will be lead to a submenu. Select On or Off and press “Enter”.

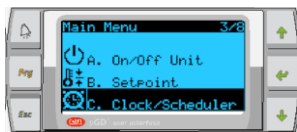

### Temperature adjustment

On the general menu select SETPOINT, a screen will appear on which you will be able to modify the value.

### System operating modes change



Control of the unit with accessories (HIT005, pGD as standard): In "General Menu" select the submenu "WINTER/SUMMER", change the operation mode on this menu.



Control of the standard unit (HITSAA01, pGD optional): In "General Menu" select the submenu "unit On/Off", change the operation mode on this menu

# OPERATION

## pGD1 or Mini PGD THERMOSTAT

### Time Schedule

**Important:** In case of having a TH-TUNE thermostat, you will previously have to deactivate it in order to make any modification on the pGD1 safely.

The start-stop from keyboard will prevail over any time schedule that it is activated.

Note: In order to accede to these menus with other controllers that are not µPC or PCO3, you will have to install the PCO100CLK0 model optional card and have enabled the clock function from the user menu (password 1996).

#### - Clock adjust in pGD1 models as standard (HIT005)

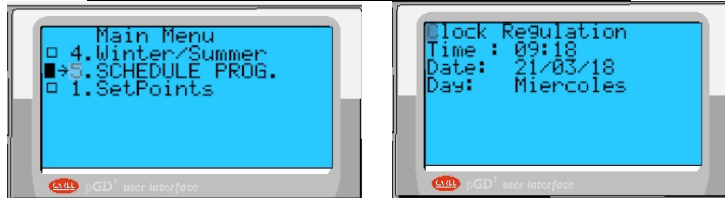

1. Press **“Prog”** key
2. Select menu 5. TIME SCHEDULE
3. Modify Hour, Date y Day

#### - Time schedule pGD1 models as standard (HIT005)

You will have 4 types of start in time schedule, and when the time schedule is ON the screen will display the word PHASE:



- A. **Manual type:** by selecting this type of start the unit will be ON or OFF without taking into account the internal clock.



Example:  
The machine will stay stopped until the type of start is changed.

- B. **ON/OFF type:** week schedule. You can define between 3 different schedules for each day of the week with until three operation time slots on each one.

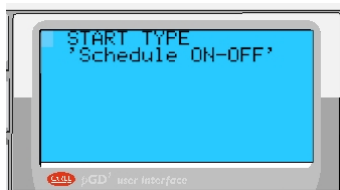

In the menu 5, select the “Schedule ON-OFF” start type.  
The three programs are defined afterwards:

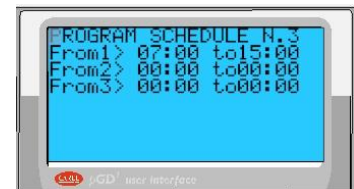
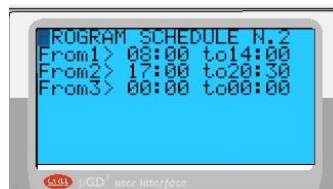
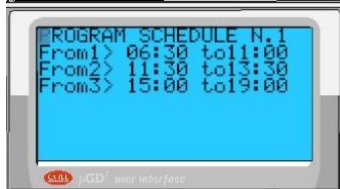

Example: From Monday to Thursday the num1 program activates, which starts up the machine at 6:30 and stops it at 11:00, starts again from 11:30 to 13:30 and from 15:00 to 19:00. On Friday the number 3 program activates, which starts up the machine from 7:00 to 15:00 and Saturdays and Sundays no program is activated, the machine remains stopped.

# OPERATION

## pGD1 or Mini PGD THERMOSTAT – Time schedule

C. **Schedule only change of Setpoint:** Similar to ON-OFF type, but in this case the unit is not stopped. The change of setpoint depends on the time slots and days selected. It is important to have into account that the work setpoint of the machine will not be modified from “Setpoint”, if not from “Clock” menu.



In the menu 5, select the “Schedule only change of Setpoint” start type. The three programs are defined afterwards:

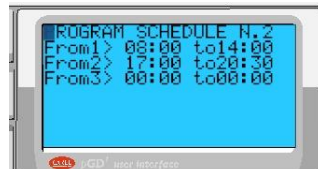
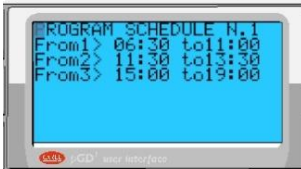

Configure the setpoint temperatures between which you will change in each section of the schedule. The internal Set is the Setpoint that it is inside the section and the external out from the section.



Example: From Monday to Thursday the program num 1 is activated, internal Setpoint from 6:30 to 11:00, etc.

D. **ON-OFF schedule type with SET limit of ON:** This option makes the start/stop as option “B”. ON-OFF schedule, including a safety start-up of the unit out of the schedule when the temperature raises or descends from one of the limit Setpoints introduced by the user. By selecting this option the “Set” setpoint screen is disabled too and it will be modified from the “Clock” key.



In menu 5, select the start-up type “Schedule ON-OFF with SET limit of ON”.

The three programs are defined afterwards:

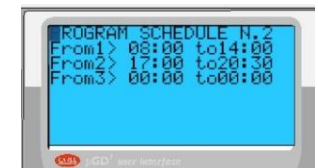

Configure the setpoint temperatures and Internal Set and the limit that will activate the machine even though it is stopped (out of the section).



Differential of temperature that you will apply to the setpoint in order to stop again the unit again.



Example: From Monday to Thursday the num1 program activates, which starts up the machine at 6:30 and stops it at 11:00, starts again from 11:30 to 13:30 and from 15:00 to 19:00. Out of these hours the machine will start if the established limits are exceeded (in cooling mode from above, under in heating mode).

# OPERATION

## pGD1 or Mini PGD THERMOSTAT – Time schedule

E. **Forced:** In the display of the type of start-up press the key “Prg” during few seconds. To deactivate this function you must press the On-Off key to stop the unit and press it again to leave the unit in the type of start-up selected previously.

This option starts the machine during an established time in hours when you have selected the time schedule and for example you are out of the schedule. When the forced time finishes the system returns to the type of start-up prior to the forced.

- Clock set when the pGD1 is an option (HITSAA01)



1. Press the **Prog** key
2. Select the C. Clock /Schedule menu
3. Modify Day, Date and hour

Enable or disable DST (Daylight Saving Time)

By default, commonly established for the EC: last Sunday of March adjust clock from 02:00 a.m. to 03:00 a.m. and the last Sunday of October readjust clock from 03:00 a.m. to 02:00 a.m.



Example:  
DST of 60 min. Enabled from the first Monday of February at 10:00 (goes off at 11:00) until the last Sunday of October at 3:00 goes back at 2:00.

- The pGD1 is an option (HITSAA01)

Various types and possible setting options are available:

A. Setting for each day of the week except public holiday. Two Setpoint values SET1 (cool) and SET2 (heat) that will be defined in the final screen.



Example:  
Start-up on Monday at 8:00 with setpoints SET1 and SET2 for Cool and Heat respectively until 14:00 and operation again from 15:00 until 20:00.

B. Schedule for up to 3 holiday periods.

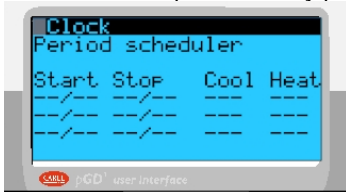

Enter the date of start and end of period together with the setpoints if it is ON or OFF.

Example:  
Period from 25/12 to 31/12 in cold and heat operation with SET1 and SET2 setpoints. From 1/8 to 31/8 SET1 setpoint Cool only.

C. Schedule for single holiday days, up to 6 different days.

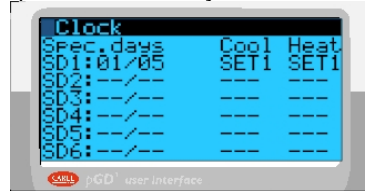

Enter the holiday day date and the setpoints, OFF when it will be Off.

Example:  
Day 1/05 in cold and heat operation with the same SET1 setpoint.

D. Configuration of the two SET1 and SET2 setpoints

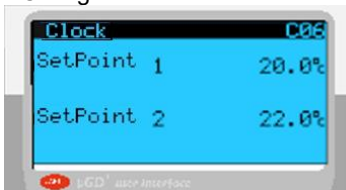

Enter the values for the two setpoints (SET1 and SET2) that you have been using when setting the programming.

Example: SET1=20°C and SET2=22°C







# OPERATION

## pGD1 or Mini PGD THERMOSTAT

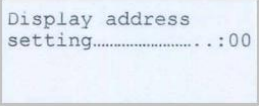
### Local Network

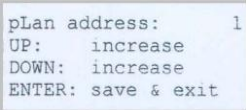
It is possible to have a single terminal to act on several connected machines forming a LOCAL NETWORK (LAN).

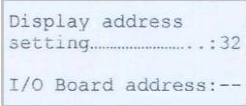
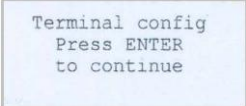
#### Addressing the units in the NETWORK:

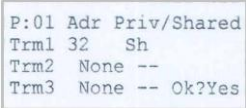
- 1 Connect the pGD terminal to the board you will address, disconnected from any network, pLan, Modbus, etc.
- 2  Press the three buttons until the next image appears on the screen, change the **Display address setting** value from 32 to 00. 
- 3 Remove voltage from the plate
- 4  Press the two buttons (alarm + upward arrow) and give voltage to the plate. The next image will appear on the screen. **pLan address:** change its value from 0 to the desired address value (1,..) 
- 5  Press the three buttons until the next image appears again on the screen, return the **display address setting** value to "32". Press Enter to confirm. 
- 6 Set **I/O Board address** to the desired value that we entered in **pLan address** press "Enter" to confirm. The following screen will appear (image) and we press again "ENTER" 
- 7  After pressing ENTER, set the following screen as shown: It indicates that our terminal (Trm1) has address 32 and that it is shared type (Sh) not private. Go to Ok? Yes and confirm. 

#### Access to the Units in the Network

Depending on the controller software:

- **Standard Unit (pGD as Optional)**

In the Main Menu select "Board Change", in the screen that will appears says the unit that we are controlling "Unit" and the unit we want to pass to "Pass to unit", we will modify this value and confirm it with Enter.

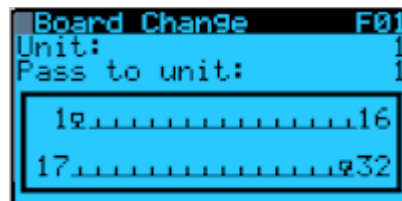

- **Units with accessories (pGD as standard)**







To access each unit press the three buttons to switch between the different units present in the LAN-NETWORK.

# OPERATION

## pGD1 or Mini PGD THERMOSTAT

### Local Network

#### **Information represented in the selected unit:**

Unit: 01	Represents the unit number to which the terminal is connected.
12:00	Indicates the actual time (only if the clock card is installed, this configuration is optional)
 / 	Indicates the mode and operation of the unit,  cold and  heat pump.
Al	Indicates whether the unit has an active alarm
20.0 °C	Indicates the return temperature
Unidad Off	Indicates unit status, multiple labels can be output Unit off per hour phase - Off Remote Unit

### Alarms

All alarms shown on the thermostat, except those with category WARNING, will cause the unit to stop.

#### **Canceling alarms:**



- This button lights up if the unit has an active alarm, pressing the button will delete the acoustic alarm, after a second press if the alarm is cleared the alarm will be cleared.
- If it is not solved, contact the technical service.

- Alarm Messages Description: pGD1 Optional (HITSAA01)

ALARM MESSAGES pGD1 (Optional: HITSAA01)	
Message in Display	Type
Alarms Clock card error or not connected	Warning
Alarms Probe B01 broken or disconnected	Warning
Alarms ThTune offline	Alarm
Alarms ThTune n. Temperature probe broken or not working	Warning
Alarms ThTune n. Humidity probe broken or not working	Warning
Alarms ThTune n. clock card error	Warning
Alarms Serious High Pressure Switch	Alarm
Alarms serious High Pressure Switch Circuit 2	Alarm
Alarms High Pressure Switch	Alarm
Alarms High Pressure Switch circuit 2	Alarm
Alarms Low Pressure Switch	Alarm
Alarms Low Pressure Switch circuit 2	Alarm
Alarms Minimum Pressure Switch	Alarm
Alarms Minimum Pressure Switch Circuit 2	Alarm
Alarms Serious Low Pressure Switch	Alarm
Alarms Serious Low Pressure Switch Circuit 2	Alarm
Alarms Serious Minimum Pressure Switch	Alarm
Alarms Serious Minimum Pressure Switch Circuit 2	Alarm
Alarms Thermic Supply Fan	Alarm
Alarms Thermic Outdoor Fan / Compressor	Alarm
Alarms Thermic Outdoor Fan / Compressor circuit 2	Alarm
Alarms low refrigeration level	Alarm
Alarms low refrigeration level circuit 2	Alarm
Alarms Probe B11 broken or disconnected	Alarm
Alarms Probe B12 broken or disconnected	Alarm
Alarms Press ENTER for History of Alarms	Alarm

# OPERATION

## pGD1 or Mini PGD THERMOSTAT

- Alarm Messages Description: pGD1 as standard (HIT005)

ALARM MESSAGES pGD1 (as standard: HIT005)	
Message / Description	Type
Thermic compressor 1	Alarm
Thermico compressor 2	Alarm
Thermico fan C1 and/or High Pressure C1	Alarm
Thermico fan C2 and/or High Pressure C2	Alarm
High room air temperature Set exceeded	Alarm
Low room air temperature Set exceeded	Alarm
Low Pressure Switch 1 and/or minimum pressure switch	Alarm
Low Pressure Switch 2 and/or minimum pressure switch	Alarm
Low Pressure Switch 1	Alarm
Low Pressure Switch 2	Alarm
Maintenance Compressor 1-C1 (Only indication)	Warning
Maintenance Compressor 1-C2 (Only indication)	Warning
Maintenance Compressor 2-C1 (Only indication)	Warning
Maintenance Compressor 2-C2 (Only indication)	Warning
Maintenance Recovery Compressor (Only indication)	Warning
Alarm severe safety thermostat Interlock.	Alarm
Defrost Probe 1 Damaged	Alarm
Defrost Probe 2 Damaged	Alarm
Dirty Filter (Only indication)	Warning
Thermic of the Heaters 1 and 2	Alarm
Thermic Heater	Alarm
General Alarm of the Burner	Alarm
Severe Damaged Memory (indication)	Warning
Missing Clock or not working	Alarm
Maintenance of the unit (Only indication)	Warning
Alarms Severe Return Temperature Probe Broken or Disconnected	Alarm
S.pLAN T/HR without connection (review pLAN Network)	Alarm
Alarm External Temperature Probe Broken or Disconnected	Alarm
Alarm Return Humidity Probe Broken or Disconnected	Alarm
Alarm External Humidity Probe Broken or Disconnected	Alarm
Alarm Supply Temperature Probe Broken or Disconnected	Alarm
Several alarm Summer Setpoint is Lower than Winter Setpoint.	Alarm
SEVERE ALARM Low Pressure 1 and / or Minimum Pressure	Alarm
SEVERE ALARM Low Pressure 2 and / or Minimum Pressure	Alarm
Maintenance indoor fan (Only indication)	Alarm
Permanent Counter Compressor 1-C1 (end, reinstall)	Alarm
Permanent Counter Compressor 1-C2 (end, reinstall)	Alarm
Permanent Counter Compressor 2-C1 (end, reinstall)	Alarm
Permanent Counter Compressor 2-C2 (end, reinstall)	Alarm
Permanent Counter Unit (end, reinstall)	Alarm
Permanent Counter Indoor Fan (end, reinstall)	Alarm
Alarm high pressure + low pressure recovery compressor	Alarm
Thermic recovery compressor	Alarm
SEVERE thermic of the Fan C1 and/or High Pressure C1	Alarm
SEVERE thermic of the Fan C2 and/or High Pressure C2	Alarm
SEVERE alarms high pressure + low pressure recovery compressor	Alarm

# MAINTENANCE



## WARNING!

**Before performing any service or maintenance of the unit, it is mandatory to disconnect and lock the system main switch to prevent anyone other than the technician from connecting the unit and causing personal injury.**

It is advisable to do maintenance works every 1.000 hours as well as at the beginning of each cooling season. In case of leakage, any manipulation and/or recovery of refrigerant must be carried out by qualified and accredited personnel in the current legislation. Add the quantity of oil that has been lost.

## CONSERVATION AND CLEANING

**Electrical circuit:** Make sure that all electrical connections –wires, contactors and terminals- are properly tight. Register the readings of kW and amperes at each compressor and fan motor phase. Verify the starting current. Check the start current. Check that all mechanical components, pressure switches and so on are working properly.

**Refrigeration circuit:** Check if there is any refrigerant leak, noises or vibration. Proceed to measuring temperatures and/or pressures of components of the most important components of the system and register them on the maintenance sheet (compressor discharge and aspiration, expansion valve, exchangers' inlet and outlet, etc...).

**Compressor:** Check regularly the lubricant level, the presence of vibrations or noise and the motor insulation.

**Coils:** At least once a year clean the condenser coils with water and detergent, then dry with air at low pressure. Never clean with a wire brush, water and/or air at high pressure (max. 6 bar).

**Fans:** Check the direction of rotation of the fans, verify their carriers. Check the transmission elements and the operating status.

Before working on the fan make sure that it is disconnected from the main power supply even though it is already stopped and control that nobody may start it during the intervention.

- A regular inspection of the unit is required to avoid dirt accumulation in propellers, turbines, motors and grids that could entail risks and significantly shorten their life. The frequency will depend on the working conditions.
- Keep the airways of the fan free – danger of expulsion of objects!
- Check the free flow of the condensation water through the evacuation openings is necessary (if there are any).
- During cleaning operations be very careful not to unbalance the propeller or the turbine.
- In case of incorrect cleaning operations no guarantee is assumed regarding corrosion formation / paint adhesion for unpainted / painted fans.
- To avoid humidity accumulation in the motor the fan must be operated during at least 1 hour at 80 to 100% of its maximum speed before cleaning!
- After the cleaning process the fan must be operated for 2 hours at 80 to 100% of maximum speed for drying purposes!
- Check the fan regularly to detect possible mechanical vibrations (recommended every 6 months). Take into consideration the limit values stated in the ISO 14694 standard and take the necessary correction measures in case of exceeding them (e.g. posterior balance by trained specialists).
- Check the impeller in particular weld-seams to detect possible cracks.

The motors and the fans do not require additional lubrication due to the use of "life-long lubrication" ball bearings. At the end of the grease life period (30-40.000h approx.) the bearing shall be replaced. Please contact our Service Department in that case as well as for any damage (e.g. to the coil or electronical parts).

## MAINTENANCE

**Transmission belts:** Check the status and tension of the transmission belt, at least twice the first month of operation, and then every 1000 hours of operation.

**Drainage system:** Verify the condition and the correct operation of the drainage tray and drain trap. It is necessary to clean the condensate trays after the first day of operation. Then, clean them at least once a year. Take into account the meteorological conditions, e.g. in areas where falling leaves or the flight of seeds may obstruct the drain trap, it will also be necessary to clean them at mid and late spring and autumn. The dates are approximate and will depend on the blooming, falling leaves, seeds, etc. of the plants of the zone or the human activity or any other cause.

**(Check the access to the condensates trays)**

**Air filters:** Clean the filters after the first operating hours to remove possible light materials such as pieces of paper or polystyrene, etc. that may have been dragged through air circulation. Clean again every 3 months (or more often depending on operation). The filters can be cleaned with soapy water. Then rinse them with clean water and let dry. If necessary replace the filters before they are in poor conditions (refer to the current legislation, EN 779, UNE-EN 13053...).

## COMPRESSOR LUBRICANT

R-410A refrigerant compressors use synthetic polyol ester oil. Each compressor manufacturer has a specific oil for their products.

The compressor or system should not remain open to atmosphere for more than 15 minutes.

Synthetic ester-type lubricants (POE, Polyol Ester) with a high solubility level with R-410A are used. These types of oil are very hygroscopic and shall be handled with more care than the conventional oils.

Moreover, when these synthetic oils are mixed with minerals (MO) or alkylbenzenes (AB), they deteriorate causing capillary blockage or failure in the compressor.

**DO NOT MIX THEM UNDER ANY CIRCUMSTANCES.**

## REFRIGERANT CHARGE



**WARNING!**

**Never use oxygen to pressurize the system or purge lines for leak test. Oxygen reacts violently with oil which may entail an explosion that could lead to damages, personal injury or event death.**

- Should it be necessary to add or recover refrigerant use a digital scale that is suitably reinforced and prepared to withstand the handling of the refrigerant bottle.
- The charge must be made in the LIQUID condition.
- The inlet of liquid refrigerant R-410A in the empty tubes causes temperatures below 0°C until the internal pressure reaches 7 bars.



**WARNING!**

**Should it be necessary to make brazing operation proceed previously to filling the circuit with dry nitrogen. Burning refrigerant produces toxic gas emissions.**

- Leaks should be repaired immediately.
- Never overcharge the system.
- Never use the compressor as a vacuum pump.
- If leakage symptoms appear during operation, proceed to a leak test.
- A HCF detector is necessary in case of small leaks.
- If a gas leak is detected proceed to removing and recuperating the entire refrigerant charge. Pressurize the system with dry nitrogen. If no leak is detected proceed to vacuuming the system and refill with refrigerant.

**Do not reintroduce the used refrigerant, send it to an authorized recycling plant.**



# DIMENSIONS

## UMXCBA / UMXCA 1602.2 – 2002.2 – 2402.2 – 3002.2

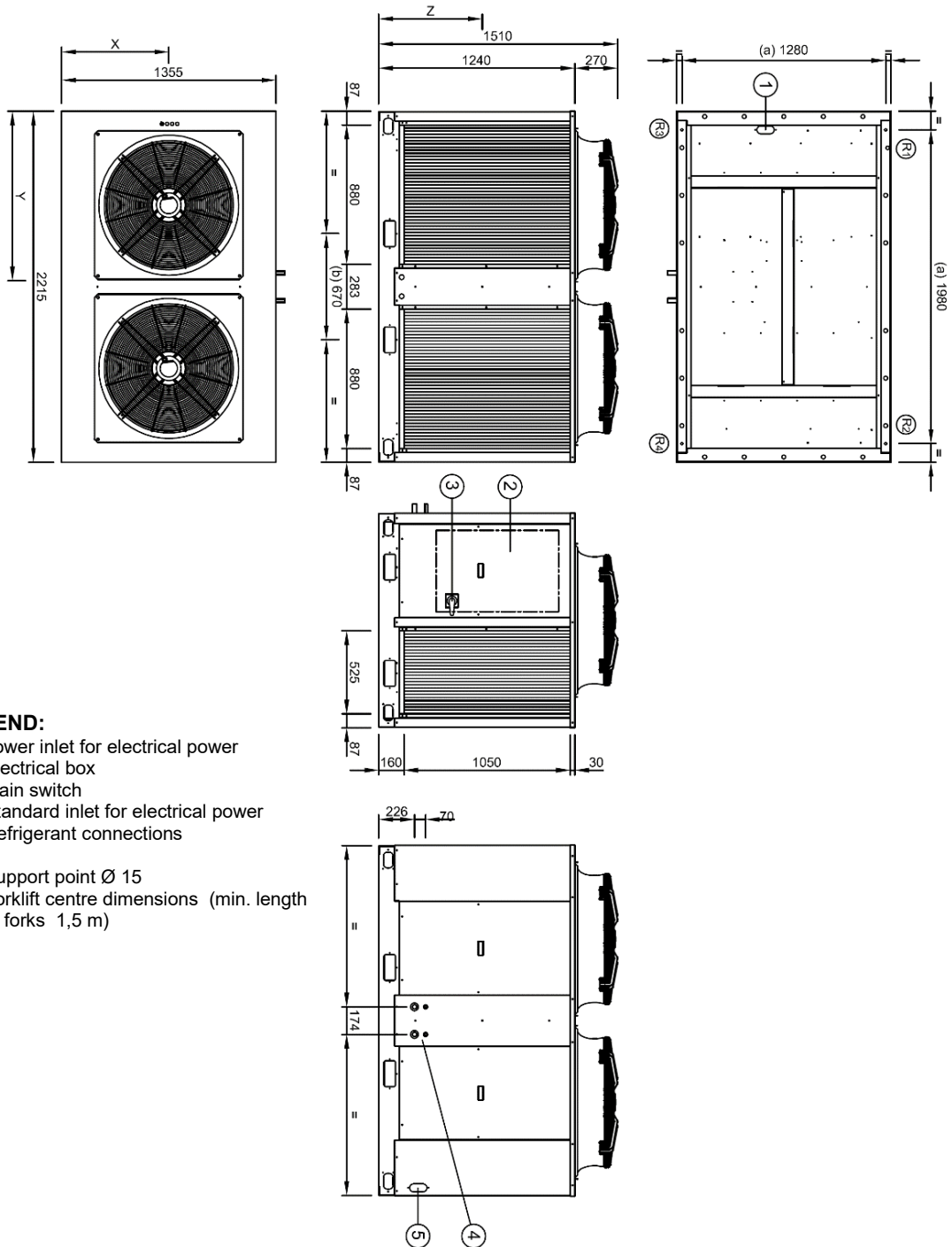

**LEGEND:**

- 1. Lower inlet for electrical power
- 2. Electrical box
- 3. Main switch
- 4. Standard inlet for electrical power
- 5. Refrigerant connections

- (a) Support point Ø 15
- (b) Forklift centre dimensions (min. length of forks 1,5 m)

CENTRE OF GRAVITY	X	Y	Z
UMXBCA 1602.2	684	1056	635
UMXBCA 2002.2	680	1057	670
UMXBCA 2402.2	680	1058	665
UMXBCA 3002.2	685	1058	672

# DIMENSIONS

## UMXCBA / UMXCA 3502.2 – 4002.2 – 4502.2

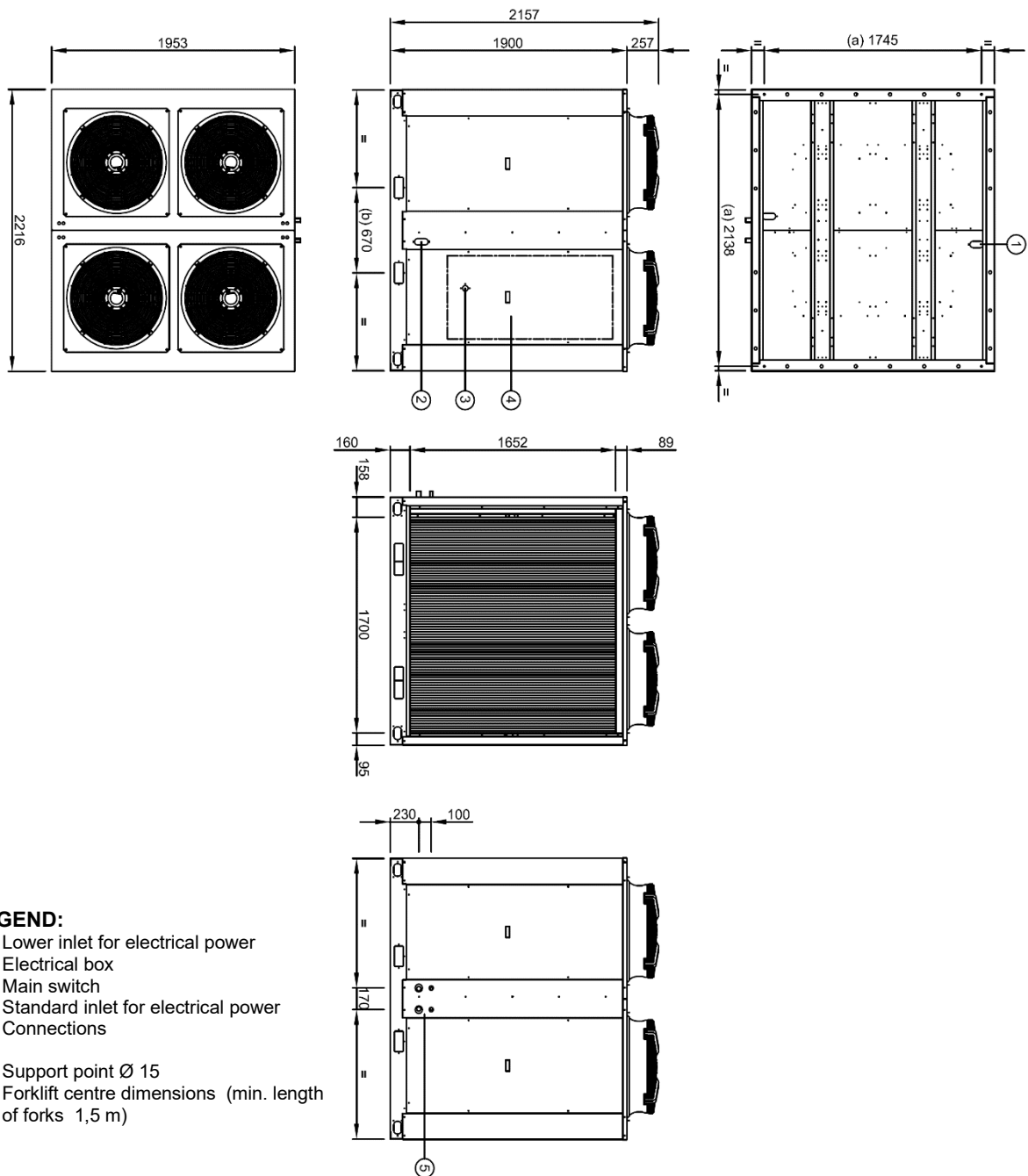

**LEGEND:**

- 6. Lower inlet for electrical power
- 7. Electrical box
- 8. Main switch
- 9. Standard inlet for electrical power
- 10. Connections

- (c) Support point Ø 15
- (d) Forklift centre dimensions (min. length of forks 1,5 m)

## APPENDIX: SAFETY DATA R410A

REFRIGERANT DATA	SAFETY DATA: R410A
Toxicity	Low
Contact with Skin	R410 A vapours can irritate the skin and eyes. In liquid form, it can freeze skin on contact. If contact with skin occurs, flush the exposed area with lukewarm water until all of the chemical is removed. If there is evidence of frostbite, bathe in lukewarm water.
Contact with Eyes	If contact with eyes occurs, immediately flush with large amounts of lukewarm water for at least 15 minutes, lifting eyelids occasionally to facilitate irrigation. Seek medical attention as soon as possible.
Ingestion	Very unlikely - should something happen, it will cause frost burns. Do not induce vomiting. Only if the patient is conscious, wash out mouth with water and give some 250 ml of water to drink. Then, obtain medical attention.
Inhalation	Inhalation of the R410A vapour may cause irritation. Vapour inhalation at high concentrations may result in asphyxiation or the heart may become sensitized, causing cardiac arrhythmia. When concentration of R410A reach levels which reduce oxygen to 14-16% by displacement, symptoms of asphyxiation will occur. An individual exposed to high concentrations of R410A must be given medical attention immediately. Adequate ventilation must be provided at all times.
Recommendations	Semiotics or support therapy is recommended. Cardiac sensitisation has been observed that, in the presence of circulating catecholamines such as adrenalin, may cause cardiac arrhythmia and accordingly, in case of exposure to high concentrations, cardiac arrest.
Prolonged Exposure	R410A: a study on the effects of exposure to 50,000 ppm during the whole life of rats has identified the development of benign testicle tumour. This situation should therefore be negligible for personnel exposed to concentrations equal to or lower than professional levels.
Professional Levels	R410A: Recommended threshold: 1000 ppm v/v - 8 hours TWA.
Stability	R410A: without specifying
Conditions to Avoid	Do not use in the presence of high temperatures, flames, burning surfaces and excess humidity.
Hazardous Reactions	Contact with certain red-hot metals may result in exothermic or explosive reactions and yield toxic and/or corrosive decomposition products. Specific materials to avoid include freshly abraded aluminium surfaces and active metals such as sodium, potassium, calcium, powdered aluminium, magnesium and zinc.
Hazardous Decomposition Products	R410A: Halogen acids produced by thermal decomposition and hydrolysis.
General Precautions	Do not inhale concentrated vapours. Their concentration in the atmosphere should not exceed the minimum preset values and should be maintained below the professional threshold. Being weightier than the air, the vapour concentrates on the bottom, in narrow areas. Therefore, the exhaust system must work at low level.
Respiratory System Protection	If you are in doubt about the concentration in the atmosphere, it is recommended to wear a respirator approved by an accident prevention Authority, of the independent or oxygen type.
Storage	Cylinders must be stored in a cool, dry and properly ventilated storage area away from heat, flames, corrosive chemicals, flumes, explosives and be otherwise protected from damage. Keep a temperature below 50°C.
Protective Clothing	Wear overalls, protective gloves and goggles or a mask.
Accidental Release Measures	It is important to wear protective clothing and a respirator. Stop the source of the leak, if you can do this without danger. Negligible leaks can be left evaporating under the sun, providing that the room is well ventilated. Considerable leaks: ventilate the room. Reduce the leak with sand, earth or other absorbing substances. Make sure that the liquid does is not channeled into gutters, sewers or pits where the vapours are likely to create a stuffy atmosphere.
Disposal	The best method is recovery and recycling. If this method is not practicable, dispose according to an approved procedure, which shall ensure the absorption and neutralization of acids and toxic agents.
Fire Fighting Information	R410A: Not flammable in the atmosphere.
Cylinders	The cylinders, if exposed to fire, shall be cooled by water jets; otherwise, if heated, they may explode.
Protective Fire Fighting Equipment	In case of fire, wear an independent respirator and protective clothing.

**BAXI CLIMATIZACIÓN, S.L.U.**  
C. López de Hoyos, 35, Planta  
Baja  
28002 Madrid  
España

Tel. +34 902 89 80 00  
[www.baxi.es](http://www.baxi.es)  
[informacion@baxi.es](mailto:informacion@baxi.es)



CE



007

**BAXI**

All rights reserved to make modifications to this catalogue without previous notice.  
Translation of original instructions.

